



COLLECTION  
LUMINAIRES  
2026





#### UNE ENTREPRISE FAMILIALE 100% FRANÇAISE

Il y a plus de trente ans, Éric Baron reprenait le flambeau de l'entreprise familiale CVL, fondée par son père Henri en 1960. Le nouveau président a très vite impulsé un virage vers le design et un parti pris contemporain. La collection de luminaires traditionnels en fer forgé et céramique a progressivement laissé place à une gamme résolument moderne, aujourd'hui réalisée en laiton massif. La qualité du matériau et la perfection des lignes sont les qualités premières qui inspirent les clients de CVL.

Forte de six décennies d'expérience, son équipe de trente-cinq salariés s'applique au quotidien à préserver et enrichir ces savoir-faire uniques dans la fabrication de luminaires en laiton, au sein d'une unité de production installée près d'Angers, dans la région Pays de la Loire...

Les artisans de CVL sont tous des hommes et femmes de l'art, passionnés par leur métier. Ils fabriquent l'intégralité des collections à la main, dans la maîtrise de gestes minutieux, au sein d'ateliers à la frontière de l'orfèvrerie et de l'industrie.

#### ESPRIT D'ÉQUIPE ET FAMILLE DE CRÉATEURS

Designer intégrée chez CVL, Émilie Cathelineau est chargée de développer les nouveaux produits et d'animer la cellule de création et le bureau d'études. Elle planche également sur les projets sur mesure: ce service est unanimement apprécié par les prescripteurs dont les requêtes pointues requièrent une expertise poussée. Sans renier son savoir-faire ancestral, CVL a su s'adapter aux nouvelles technologies et s'est dotée de logiciels de création performants, permettant la réalisation de fichiers et rendus 3D indispensables à ses clients.

Depuis plusieurs années, l'entreprise a su s'ouvrir au regard et à l'inventivité de designers indépendants tels que Hervé Langlais, Pauline Deltour, POOL studio ou Sylvain Willenz. Ces fructueuses collaborations sont le gage d'une image de marque modernisée, mais aussi de nouvelles collections, toujours en harmonie avec l'esprit CVL.

#### A 100% FRENCH FAMILY COMPANY

More than 30 years ago, Éric Baron took over the family business CVL, founded by his father Henri in 1960. The new president very quickly initiated a shift towards design and a contemporary bias. The collection of traditional wrought iron and ceramic lights has gradually given way to a resolutely modern range, now made of solid brass. The quality of the material and the perfection of the lines are the primary qualities that inspire CVL's clients.

With six decades of experience, its team of thirty-five employees works daily to preserve and enrich their unique know-how in the manufacture of brass lighting, within a production unit located near Angers, in the region of the Loire Valley...

CVL artisans are all men and women of art, passionate about their work. They produce all of the collections by hand, mastering meticulous techniques, in workshops on the border line between goldsmith and industry.

#### TEAM SPIRIT AND FAMILY OF DESIGNERS

Integrated designer at CVL, Émilie Cathelineau is responsible for developing new products and responsible for leading the creation unit and the design office. She also works on bespoke projects: this service is unanimously appreciated by specifiers whose specific requests require in-depth expertise. Without denying its ancestral know-how, CVL has been able to adapt to new technologies and is equipped with high-performance creation software, allowing the creation of 3D files and renderings essential to its customers.

Over the years, the company has opened up to the inventiveness of independent designers such as Hervé Langlais, Pauline Deltour, POOL studio or Sylvain Willenz. These fruitful collaborations are the pledge of a modernized brand image, but also of new collections, always in harmony with the CVL spirit.





#### **UNE DISTRIBUTION INTERNATIONALE ET DES PROJETS À TRAVERS LE MONDE**

Forte d'un solide réseau de partenaires, CVL est représentée sur les cinq continents. L'entreprise familiale expose régulièrement ses créations dans les salons les plus prestigieux: Euroluce à Milan, ICFF à New York, Maison et Objet, Architect@Work et Equip'Hotel à Paris... Ses clients, architectes et décorateurs, plébiscitent ses luminaires dans le cadre de leurs projets, résidentiels comme hôteliers. CVL peut s'enorgueillir de sa présence dans des aménagements privés de standing autant que des rénovations hôtelières de prestige et des boutiques de luxe: Waldorf Astoria, Marriott, Four Seasons, Crowne Plaza, Cartier, Boucheron, Harrods... pour n'en citer que quelques-uns.

#### **UN SAVOIR-FAIRE RECONNU ET RECHERCHÉ**

Les architectes d'intérieur et décorateurs à la recherche d'un savoir-faire artisanal de haut niveau sont nombreux à confier la réalisation de leurs pièces à CVL. L'entreprise est en permanence à l'écoute de ses clients et de leurs besoins. Elle a développé un regard pointu, tourné vers l'architecture, sans compromis ni concession sur la technicité et la performance. La maîtrise de toutes les étapes de production – dès le prototypage réalisé en interne – et des technologies de l'éclairage, permettent à CVL d'offrir flexibilité et rapidité d'exécution, deux vertus indispensables pour ses clients. Depuis de nombreuses années, CVL travaille également en partenariat avec des maisons d'éditions en France comme à l'étranger, qui lui confient le développement et la fabrication de leurs gammes de luminaires. Que ce soit pour des pièces uniques ou des séries, cette PME est constamment en phase d'auto-évaluation. Elle s'adapte en permanence aux avancées des technologies LED et crée des luminaires sophistiqués qui répondent aux normes internationales de plus en plus strictes. La certification «UL» des produits pour le marché nord-américain, et le développement d'une collection destinée à la salle de bain sont de parfaites illustrations de cette philosophie d'amélioration constante. Pour une qualité irréprochable, chaque produit est vérifié et testé avant emballage.

#### **INTERNATIONAL DISTRIBUTION AND PROJECTS AROUND THE WORLD**

With a strong network of partners, CVL is represented on all five continents. The family business regularly exhibits its creations at the most prestigious fairs: Euroluce in Milan, ICFF in New York, Maison et Objet, Architect@Work and Equip'Hotel in Paris... CVL's clients, architects and decorators, select its lighting as part of their projects, both residential and commercial. CVL can be proud of its presence in luxury private facilities as well as prestigious hotel renovations and luxury boutiques: Waldorf Astoria, Marriott, Four Seasons, Crowne Plaza, Cartier, Boucheron, Harrods... to only quote a few.

#### **A RECOGNIZED AND SOUGHT-AFTER KNOW-HOW**

Many interior architects and decorators looking for high-level craftsmanship entrust the creation of their pieces to CVL. The company is constantly attentive to its customers and their needs. It has developed a sharp eye for architecture, with no compromises or concessions on technical performance. The control of all stages of production, from prototyping carried out internally and lighting technologies, allow CVL to offer flexibility and speed of execution, two essential virtues for its customers. For many years, CVL has also worked in partnership with publishing houses in France and abroad, who entrust the company with the development and manufacture of their lighting ranges. One-offs or series, this SMB is always questioning itself, constantly adapting, for example, to the evolution of LED technologies and developing complex luminaires that meet ever more demanding international standards. The "UL" certification of products for the North American market, and the development of a bathroom collection, are perfect illustrations of this philosophy of constant improvement. For impeccable quality, each product is checked and tested before packaging.



## LA RECONNAISSANCE EPV

CVL Luminares est fière de faire désormais partie des rares entreprises labellisées Entreprise du Patrimoine Vivant (EPV), récompense remise par le préfet de la région en décembre 2023. Ce label distingue des entreprises qui détiennent un savoir-faire artisanal ou industriel exceptionnel, contribuant ainsi à la richesse du patrimoine économique français. Les entreprises labellisées EPV sont sélectionnées pour leur excellence, leur tradition et leur capacité à innover dans leur domaine.

Le processus d'obtention du label EPV est rigoureux. Les entreprises candidates sont évaluées selon plusieurs critères, tels que la maîtrise des techniques traditionnelles, la qualité de la production, l'ancienneté du savoir-faire, ainsi que leur engagement en matière de Responsabilité Sociétale des Entreprises (RSE). Seules celles qui répondent à des normes élevées et qui incarnent véritablement l'excellence dans leur secteur peuvent prétendre à cette distinction.

Le label EPV est une marque de qualité et de reconnaissance qui offre une visibilité significative aux entreprises qui en bénéficient. Il témoigne non seulement de l'authenticité et de la valeur du patrimoine économique français, mais il contribue également à promouvoir l'innovation et la pérennité des savoir-faire traditionnels.

Ainsi, lorsqu'une entreprise arbore le label EPV, cela signifie qu'elle incarne l'excellence, la tradition, l'innovation et s'engage activement dans des pratiques responsables, faisant d'elle une ambassadrice remarquable du patrimoine vivant français.



## EPV RECOGNITION

CVL Luminares is proud to be one of only a handful of companies to have been awarded the Entreprise du Patrimoine Vivant (EPV) label, an award presented by the regional prefect in December 2023. This certification label distinguishes companies with exceptional craftsmanship or industrial know-how, contributing to the richness of France's economic heritage. EPV-labeled companies are selected for their excellence, tradition and ability to innovate in their field.

The process for obtaining the EPV label is a rigorous one. Candidate companies are evaluated according to a number of criteria, including their mastery of traditional techniques, the quality of their production, the existence of their know-how, and their commitment to Corporate Social Responsibility (CSR). Only those that meet high standards and truly embody excellence in their sector can claim this distinction.

The EPV label is a mark of quality and recognition that offers significant visibility to the companies that benefit from it. Not only does it testify to the authenticity and value of France's economic heritage, it also helps promote innovation and the sustainability of traditional know-how.

So, when a company carries the EPV label, it means that it embodies excellence, tradition and innovation, and is actively committed to responsible practices, making it an outstanding ambassador of France's living heritage.



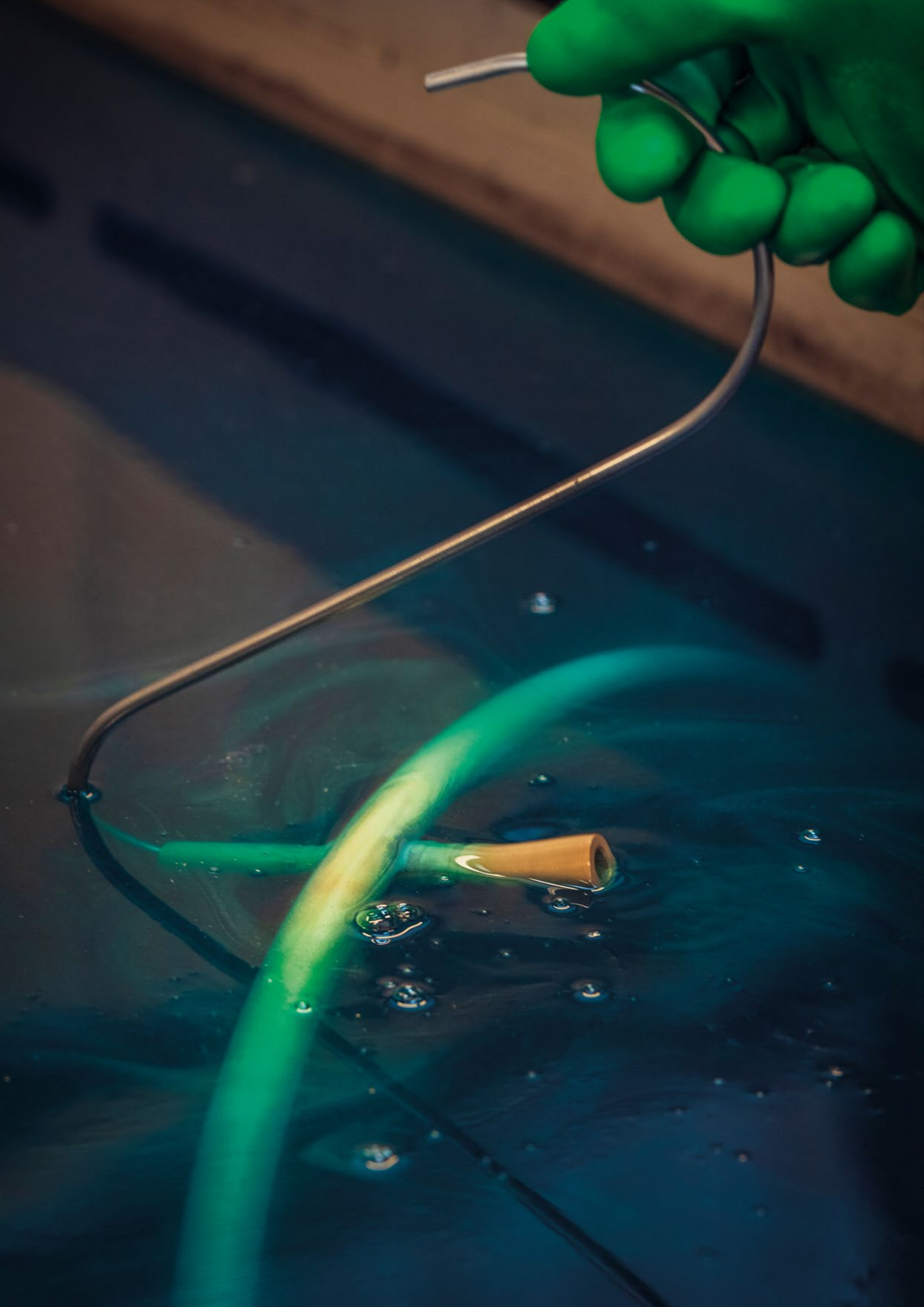

## CVL LUMINAIRES : LE FUTUR DURABLE

CVL Luminaires est fière de son engagement envers ses collaborateurs et l'environnement, car elle croit que chaque produit créé devrait éclairer le monde tout en respectant la planète et ses habitants. Voici quelques-unes des actions concrètes que nous menons pour façonner un avenir plus durable :

### 1. Bien-être des employés

La santé et le bien-être des collaborateurs sont au cœur des préoccupations. Par exemple, CVL veille constamment à la réduction du niveau sonore de ses machines et de ses locaux. Ces derniers, par ailleurs, disposent d'un éclairage naturel : confort acoustique et lumineux créent un environnement propice au bien-être de chacun.

### 2. Protection de la santé

L'entreprise accorde une importance capitale à la santé de ses salariés, en mettant en place des mesures exigeantes pour assurer un environnement de travail sûr et sain. Par exemple, des systèmes de ventilation ont été spécialement étudiés afin de capter les émissions de poussière et de particules à la source et les retraiter.

### 3. Formation et emploi

En partenariat avec France Travail et des organismes de formation, CVL offre des formations diplômantes en interne à ses nouveaux collaborateurs. Cette initiative vise à favoriser l'insertion professionnelle tout en renforçant les compétences des équipes.

### 4. Recyclage de l'eau

Soucieuse de la protection de l'environnement, CVL a adopté un fonctionnement en rejet zéro pour les eaux utilisées dans le processus de production. L'eau est maintenue en circuit fermé dans l'usine où elle est recyclée puis réutilisée en continu.

### 5. Contrôles environnementaux

L'entreprise effectue également régulièrement des contrôles et des analyses approfondis sur ses rejets atmosphériques, s'assurant ainsi d'être très en deçà des normes environnementales les plus strictes.

### 6. Zéro perte

La récupération des chutes de matières premières fait partie intégrante du processus de fabrication. Ainsi, les déchets sont minimisés et recyclés.

### 7. Emballages durables

Dans une démarche de réduction de son empreinte environnementale, les emballages en polystyrène et les boîtes plastiques ont été abandonnés à la faveur du papier froissé et du carton recyclé.

## CVL LUMINAIRES: A SUSTAINABLE FUTURE

CVL Luminaires is proud of its commitment towards its employees and the environment, believing that every product it creates should light up the world while respecting the planet and its inhabitants. Here are some of the concrete actions we carry out to build a more sustainable future:

### 1. Employee well-being

The health and well-being of our employees is a core concern. For example, CVL constantly strives to reduce the noise level of its machines and premises. In addition, the latter also have natural lighting: acoustic and lighting comfort create an environment that favors everyone's well-being.

### 2. Health protection

The company attaches the utmost importance to the health of its employees, implementing stringent measures to ensure a safe and healthy working environment. For example, ventilation systems have been specially designed to capture dust and particle emissions at source and reprocess them.

### 3. Training & employment

In partnership with France Travail and training organizations, CVL offers its new employees in-house training leading to a diploma. This initiative aims to promote professional integration while strengthening the skills of its teams.

### 4. Water recycling

To protect the environment, CVL has adopted a zero-discharge operation for water used in the production process. The water is kept in a closed circuit in the factory, where it is recycled and reused continuously.

### 5. Environmental controls

The company also regularly carries out in-depth checks and analyses on its atmospheric emissions, ensuring that it remains well below the most stringent environmental standards.

### 6. Zero Waste

The recovery of raw material offcuts is an integral part of the manufacturing process. Thus, waste is minimized and recycled.

### 7. Sustainable packaging

In an approach to reduce its environmental footprint, polystyrene packaging and plastic boxes have been abandoned in favor of crumpled paper and recycled cardboard.

## DESIGNERS



### ÉMILIE CATHELINEAU

Lorsqu'Émilie Cathelineau rejoint CVL en tant que designer intégrée en 2003, l'entreprise n'a pas encore de bureau de création. Sa mission : faire évoluer la gamme encore très classique, mais reconnue pour la qualité de ses finitions. Spécialiste du luminaire, elle est la personne de référence pour le développement de produits et fait le lien avec les autres designers. Aujourd'hui, Émilie a plus d'une dizaine de collections à son actif. Déclinées sous toutes les formes de luminaires, elles empruntent leur style autant aux mouvements Art déco qu'au design contemporain.

When Émilie Cathelineau became part of CVL as a designer back in 2003 the company did not yet have a design studio. Her mission was to develop the existing classic range which was known for its quality and various finishes. As an expert in lighting, she is the person in charge for the development of the products and goes over changes and novelties with the other designers. At present, Émilie has designed over ten collections. Made up of all sorts and forms of lights, her collections are inspired from other Art Déco styles to contemporary designs.



### PAULINE DELTOUR

Après Olivier de Serres et l'École Nationale Supérieure des Arts Décoratifs de Paris, Pauline Deltour part, durant trois ans, assister à Munich le designer allemand Konstantin Grcic. Elle apprend à ses côtés son métier, envisage de nouvelles méthodes de travail et approfondit son vocabulaire stylistique. En 2011, armée d'une expérience solide, Pauline Deltour revient à Paris et monte son entreprise de design d'objets. Elle collabore également à des projets de scénographie en architecture d'intérieur. En 2017, elle rejoint l'équipe de créateurs de CVL et dessine la collection Signal.

After studying at Olivier de Serres and Paris's famous École nationale supérieure des arts décoratifs, Pauline Deltour assisted the German designer Konstantin Grcic during three years. During her time with him she learnt more about her job, considered new working skills and gained further stylistic vocabulary. In 2011 Pauline Deltour returned to Paris, with even more experience, and set up her own company of designing objects. She also collaborated on interior design projects. In 2017 she joined CVL's designer team and created the Signal collection.



### JEAN-BAPTISTE FASTREZ

Jean-Baptiste Fastrez est un designer français, né en 1984. En 2010, il est diplômé de l'ENSCI / Les Ateliers de Paris avec mention. Après avoir collaboré pendant trois ans avec Ronan et Erwan Bouroullec, le designer ouvre son propre studio en 2011 où il se concentre sur différents projets de produits et d'espaces en éditions limitées et en design industriel. Ses œuvres font partie des collections permanentes du Centre Pompidou et du Musée des Arts Décoratifs de Paris et de Bordeaux, de la Villa Noailles à Hyères ainsi que de la collection du CNAP (Comité National des Arts Plastiques).

Jean-Baptiste Fastrez is a french designer, born in 1984. In 2010, he graduated from ENSCI / Les Ateliers de Paris with honors. After collaborating for three years with Ronan and Erwan Bouroullec, the designer opened his own studio in 2011 where he focuses on different product and space projects in limited editions and industrial design. His works are part of the permanent collections of the Centre Pompidou and the Museum of Decorative Arts in Paris and Bordeaux, the Villa Noailles in Hyères as well as of the collection of the CNAP (Comité National des Arts Plastiques).



### HERVÉ LANGLAIS

Architecte de formation, Hervé Langlais collabore de nombreuses années avec Paul Andreu, spécialiste français des constructions aéroportuaires, et y dessine le Grand Théâtre National de Chine à Pékin ou encore l'Oriental Art Center à Shanghai. Vingt ans plus tard, il retrouve ses premières amours et développe une activité de designer produit. Cet ancien dessinateur de structure accorde une attention particulière aux détails, aux formes épurées et à la rareté des matériaux. Premier designer indépendant à officier pour CVL.

Trained as an architect, Hervé Langlais collaborated for many years with Paul Andreu, a specialist in airport constructions, and together designed the National Centre for the Performing Arts in Beijing in China and even the Shanghai Oriental Art Center. Twenty years later, he started again doing what he loved and developed an activity as a product designer. This former building designer grants specific importance to each detail, refined form and to the rarity of materials. Hervé was the first independent designer to become part of the CVL team.



### JOSÉ LÉVY

José Lévy est un artiste parisien et un voyageur qui navigue avec talent et poésie fantaisiste entre la mode, les arts décoratifs, le design et les installations muséales. Ses champs d'action sont divers. Fournisseur d'objets singuliers et intimes, José Lévy tisse des liens entre ses créations et leurs bénéficiaires. Recréant des souvenirs, propres ou empruntés, José Lévy insufflé à son travail un sens unique de la rigueur et de l'imagination.

José Lévy is a Parisian artist and traveller who navigates with talent and whimsical poetry between fashion, decorative arts, design and museum installations. His fields of action are diverse. A purveyor of singular, intimate objects, José Lévy weaves links between his creations and their recipients. Recreating memories, both own and borrowed, José Lévy infuses his work with a unique sense of rigour and imagination.



### POOL

Le studio de création parisien, fondé en 2011 par Léa Padovani et Sébastien Kieffer, intervient autant dans les champs du mobilier, de l'environnement que de l'architecture d'intérieur. Collections signées ou collaborations avec d'autres ateliers et manufactures, le duo POOL réfléchit ses créations dans leur contexte global. La composition géométrique, où formes et couleurs agencent des volumes radicaux, se décline comme une véritable marque de fabrique du tandem transdisciplinaire.

The Parisian design studio, founded in 2011 by Léa Padovani and Sébastien Kieffer, intervenes in as much domains as furniture, environment, and interior architecture. The duo POOL studies its creations in a global context, either when signing their own collections or collaborating with other workshops and manufacturers. The geometric composition, in which shapes and colors combine to form radical volumes, is a true trademark of the transdisciplinary tandem.



### SYLVAIN WILLENZ

Né à Bruxelles en 1978, Sylvain Willenz a vécu aux États-Unis, en Belgique et en Grande Bretagne. Diplômé du Royal College of Art de Londres en 2003, Willenz ouvre un an plus tard son bureau de design à Bruxelles. Willenz fut nommé designer Belge de l'année en 2009. Connu pour son esthétique simple et graphique, Willenz est fasciné par la l'industrie et l'artisanat, la production et les matériaux. Au cours des années, il a développé un style singulier, une ligne claire, insufflant ainsi à ses créations une élégance unique, classique et si reconnaissable aujourd'hui.

Born in Brussels in 1978, Sylvain Willenz has lived consecutively in the US, Belgium and in the UK. Sylvain studied MA Design Products at the Royal College of Art in London, graduating in 2003. In 2004, he opened his Design Office, based in Brussels, Belgium. Willenz was named Belgian Designer of the Year in 2009. Renown for his strong yet simple graphic aesthetic, Sylvain is fascinated by production, manufacturing and pays great attention to detail. Over the years, he has developed a singular style, a "ligne claire", impregnating his creations with a unique and classical elegance that is today so recognizable.



## INDEX

### A

- 18 **Airy** Appliques – Wall lights
- 22 **Arborescence** Suspensions – Pendants
- 25 **Arborescence** Appliques – Wall lights
- 25 **Arborescence** Lampes de table – Table lamps
- 30 **Arborescence** Lampadaires – Floor lamps
- 32 **Atmos** Appliques – Wall lights

### C

- 40 **Calé(e)** Suspensions – Pendants
- 50 **Calé(e)** Appliques – Wall lights
- 52 **Calé(e)** Lampes de table – Table lamps
- 54 **Calé(e)** Lampadaires – Floor lamps
- 59 **Candy** Suspensions – Pendants
- 56 **Candy** Appliques – Wall lights
- 60 **Candy** Spots
- 61 **Candy** Lampes de table – Table lamps
- 56 **Candy** Lampadaires – Floor lamps
- 62 **Carta** Appliques – Wall lights
- 68 **Cercle & trait** Suspensions – Pendants
- 74 **Cercle & trait** Potence – Deported wall lamp
- 75 **Cercle & trait** Liseuse – Standing reading lamp
- 77 **Cercle & trait** Lampadaire – Floor lamp
- 81 **Clopes** Suspensions – Pendants
- 78 **Clopes** Lampadaire – Floor lamp
- 86 **Co Lampe de table** – Table lamp
- 90 **Compass** Suspension – Pendant
- 92 **Compass** Applique – Wall light
- 94 **Constellation** Appliques – Wall lights
- 100 **Couture** Lampe de table – Table lamp

### E

- 104 **Earth** Appliques – Wall lights
- 112 **Éclipse** Applique – Wall light
- 116 **Extra** Suspensions – Pendants

### F

- 120 **Fléa** Suspensions – Pendants
- 121 **Fléa** Appliques – Wall lights

### G

- 124 **Gamma** Suspensions – Pendants
- 124 **Gamma** Appliques – Wall lights

### H

- 132 **Hausmann Applique** – Wall light

### J

- 136 **Janed** Appliques – Wall lights
- 142 **Janed** Lampe de table – Table lamp

### L

- 144 **Link** Appliques – Wall lights
- 147 **Link** Liseuses – Reading wall lights
- 154 **Link** Lampadaire – Floor lamp
- 156 **Louis** Suspensions – Pendants

### M

- 166 **Moulure** Appliques – Wall lights
- 162 **Moulure** Lampe de table – Table lamp

### N

- 164 **Naboo** Appliques – Wall lights
- 176 **Nacho** Suspensions – Pendants

### P

- 181 **Paradoxe** Suspensions – Pendants
- 192 **Pirouette** Appliques – Wall lights

### R

- 196 **Ruban** Lampe de table – Table lamp

### S

- 200 **Saturne** Suspension – Pendant
- 204 **Scala** Appliques – Wall lights
- 208 **Signal** Suspensions – Pendants
- 211 **Signal** Appliques – Wall lights
- 218 **Signal** Lampadaires – Floor lamps
- 220 **Solitaire** Lampadaires – Floor lamps
- 224 **Storm** Suspension – Pendant
- 227 **Storm** Applique – Wall light
- 227 **Storm** Lampadaire – Floor lamp
- 226 **Storm** Lampes de table – Table lamps
- 230 **Strate** Appliques – Wall lights

### T

- 242 **Tétra** Applique – Wall light

### U

- 246 **Upper** Lampadaire – Floor lamp

## SALLE DE BAIN BATHROOM

- 252 **IP Backstage** Appliques – Wall lights
- 258 **IP Calé(e)** Appliques – Wall lights
- 260 **IP Cornet** Appliques – Wall lights
- 262 **IP Gamma** Appliques – Wall lights
- 264 **IP Janed** Appliques – Wall lights
- 266 **IP Link** Appliques – Wall lights
- 270 **IP Metrop** Appliques – Wall lights
- 274 **IP Signal** Appliques – Wall lights
- 278 **IP Storm** Appliques – Wall lights

- 285 **Finitions / Finishes**

**SUSPENSIONS – PENDANT LIGHTS**

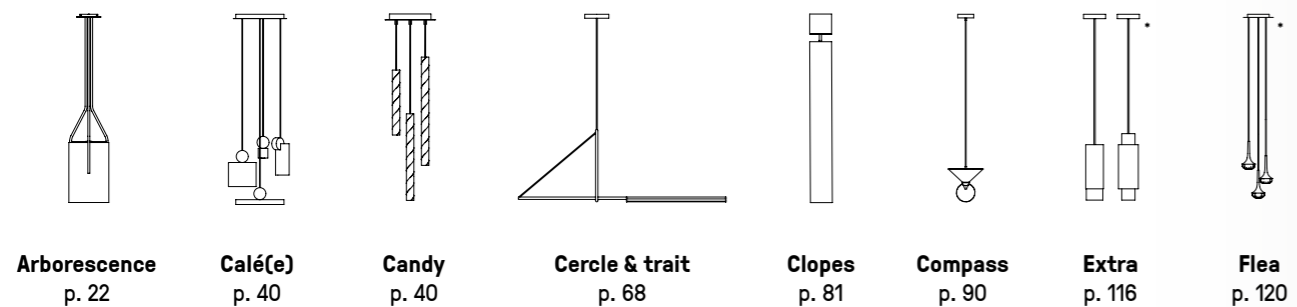

**Arborescence** p. 22  
**Calé(e)** p. 40  
**Candy** p. 40  
**Cercle & trait** p. 68  
**Clopes** p. 81  
**Compass** p. 90  
**Extra** p. 116  
**Flea** p. 120

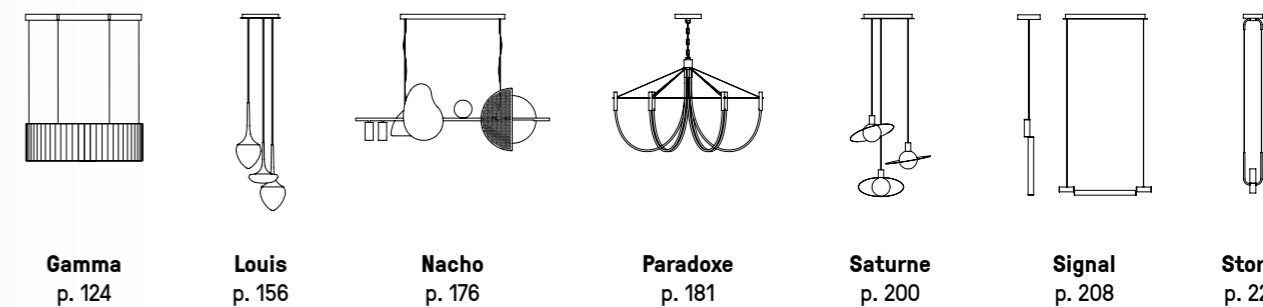

**Gamma** p. 124  
**Louis** p. 156  
**Nacho** p. 176  
**Paradoxe** p. 181  
**Saturne** p. 200  
**Signal** p. 208  
**Storm** p. 224

**APPLIQUES – WALL LIGHTS**

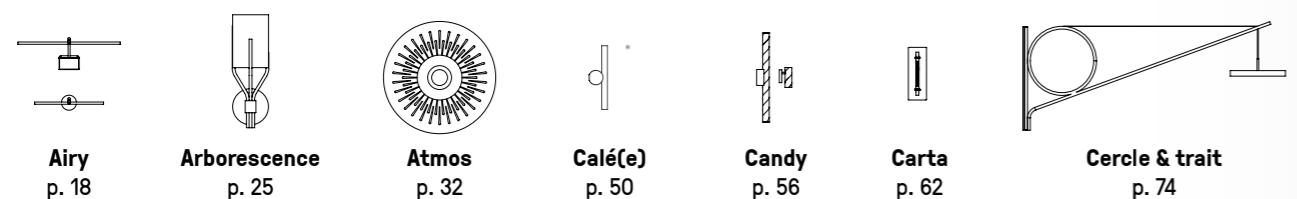

**Airy** p. 18  
**Arborescence** p. 25  
**Atmos** p. 32  
**Calé(e)** p. 50  
**Candy** p. 56  
**Carta** p. 62  
**Cercle & trait** p. 74

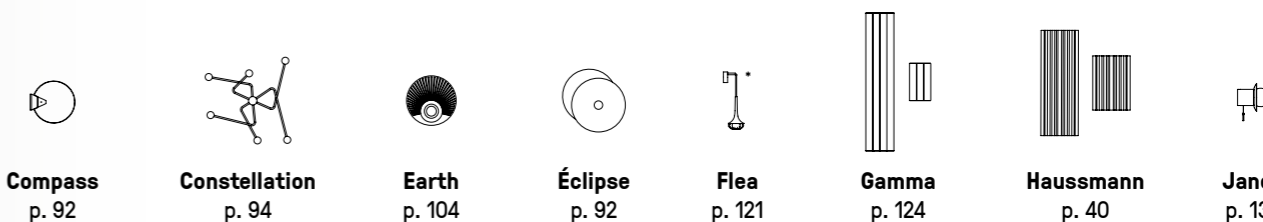

**Compass** p. 92  
**Constellation** p. 94  
**Earth** p. 104  
**Éclipse** p. 92  
**Flea** p. 121  
**Gamma** p. 124  
**Haussmann** p. 40  
**Janed** p. 136

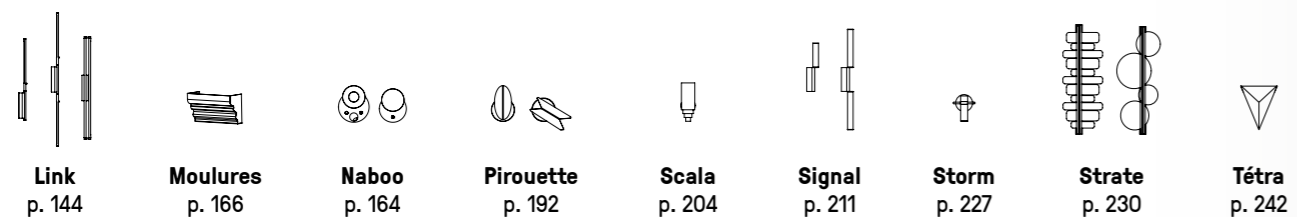

**Link** p. 144  
**Moulures** p. 166  
**Naboo** p. 164  
**Pirouette** p. 192  
**Scala** p. 204  
**Signal** p. 211  
**Storm** p. 227  
**Strate** p. 230  
**Tétra** p. 242

**LAMPES DE TABLE – TABLE LAMPS**

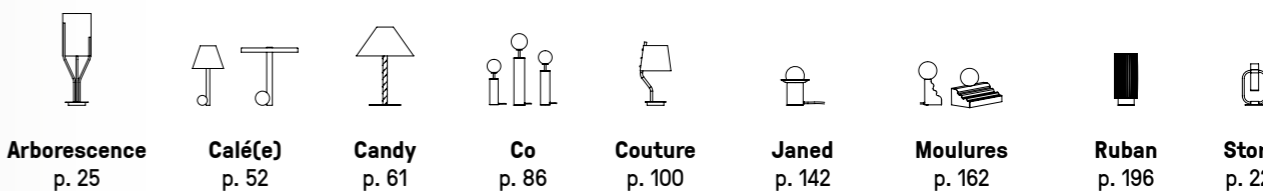

**Arborescence** p. 25  
**Calé(e)** p. 52  
**Candy** p. 61  
**Co** p. 86  
**Couture** p. 100  
**Janed** p. 142  
**Moulures** p. 162  
**Ruban** p. 196  
**Storm** p. 226

**LAMPADAIRES – FLOOR LAMPS**

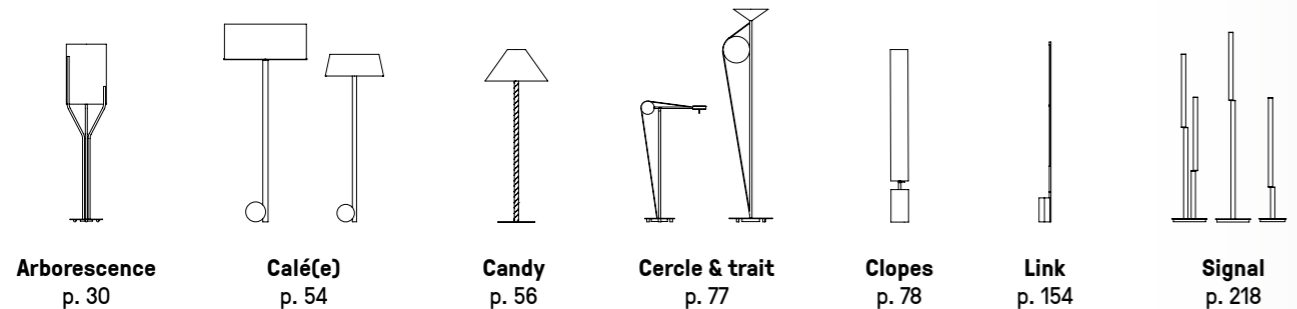

**Arborescence** p. 30  
**Calé(e)** p. 54  
**Candy** p. 56  
**Cercle & trait** p. 77  
**Clopes** p. 78  
**Link** p. 154  
**Signal** p. 218

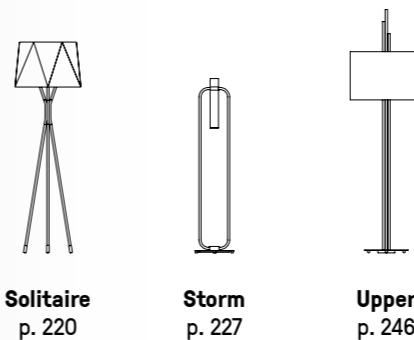

**Solitaire** p. 220  
**Storm** p. 227  
**Upper** p. 246

**SALLE DE BAIN – BATHROOM**

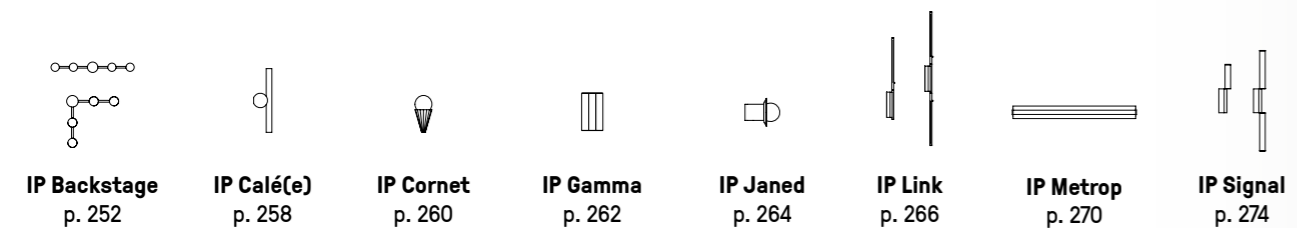

**IP Backstage** p. 252  
**IP Calé(e)** p. 258  
**IP Cornet** p. 260  
**IP Gamma** p. 262  
**IP Janed** p. 264  
**IP Link** p. 266  
**IP Metrop** p. 270  
**IP Signal** p. 274



**IP Storm** p. 278



## AIRY

Gamme de réflecteurs tableaux épurés et graphiques, la collection est disponible dans de nombreuses options de longueur et de socles. L'applique *Airy* sait se faire discrète pour une mise en lumière de l'œuvre qu'elle accompagne.



A range of sleek, graphic picture lights, this collection is available in numerous lengths for the reflector and shapes for the base. The *Airy* wall light is discreet enough to highlight the work it is illuminating.

**Finitions**  
**Finishes**

Détails page 285

|                                    |   |                                     |                                     |                       |
|------------------------------------|---|-------------------------------------|-------------------------------------|-----------------------|
| ● Laiton satiné<br>SB Satin brass  | ● Graphite satiné<br>SG Satin graphite  | ● Nickel satiné<br>SN Satin nickel  | ● Cuivre satiné<br>SC Satin copper  | ● Bronze<br>BZ Bronze |
| ● Laiton poli<br>PB Polished brass | ● Graphite poli<br>PG Polished graphite | ● Nickel poli<br>PN Polished nickel | ● Cuivre poli<br>PC Polished copper |                       |

**Matériaux**  
**Materials**

|   |   |  |
|---|---|--|
| <b>Tous – All</b><br>Laiton massif<br>Solid Brass | <b>Tous – All</b><br>Diffuseur polycarbonate satiné<br>Satin Polycarbonate diffuser | <b>Airy Potence</b><br>Socle aluminium peint noir<br>Black painted aluminum base |
|---|---|--|

**Source**  
**Lamping**

Valeurs nominales  
Nominal values

|  |                                  |                                 |                      |
|--|----------------------------------|---------------------------------|----------------------|
| <b>Airy 214 R/L/P (214 mm – 8.4")</b>    | LED intégrée 192lm 2700°K 4W     | Alim. électronique 24V intégrée | Variable (phase cut) |
|  | Integrated LED 192lm 2700°K 4W   | Int. power supply 24V included  | Dimmable (phase cut) |
| <b>Airy 414 R/L/P (414 mm – 16.3")</b>   | LED intégrée 384lm 2700°K 6W     | Alim. électronique 24V intégrée | Variable (phase cut) |
|  | Integrated LED 384lm 2700°K 6W   | Int. power supply 24V included  | Dimmable (phase cut) |
| <b>Airy 514 R/L/P (514 mm – 20.2")</b>   | LED intégrée 480lm 2700°K 8W     | Alim. électronique 24V intégrée | Variable (phase cut) |
|  | Integrated LED 480lm 2700°K 8W   | Int. power supply 24V included  | Dimmable (phase cut) |
| <b>Airy 614 R/L/P (614 mm – 24.2")</b>   | LED intégrée 576lm 2700°K 9W     | Alim. électronique 24V intégrée | Variable (phase cut) |
|  | Integrated LED 576lm 2700°K 9W   | Int. power supply 24V included  | Dimmable (phase cut) |
| <b>Airy 814 R/L/P (814 mm – 32")</b>     | LED intégrée 768lm 2700°K 11W    | Alim. électronique 24V intégrée | Variable (phase cut) |
|  | Integrated LED 768lm 2700°K 11W  | Int. power supply 24V included  | Dimmable (phase cut) |
| <b>Airy 1014 R/L/P (1014 mm – 39.9")</b> | LED intégrée 960lm 2700°K 13W    | Alim. électronique 24V intégrée | Variable (phase cut) |
|  | Integrated LED 960lm 2700°K 13W  | Int. power supply 24V included  | Dimmable (phase cut) |
| <b>Airy 1214 L/P (1214 mm – 47.8")</b>   | LED intégrée 1152lm 2700°K 15W   | Alim. électronique 24V intégrée | Variable (phase cut) |
|  | Integrated LED 1152lm 2700°K 15W | Int. power supply 24V included  | Dimmable (phase cut) |
| <b>Airy 1414 L/P (1414 mm – 55.7")</b>   | LED intégrée 1344lm 2700°K 17W   | Alim. électronique 24V intégrée | Variable (phase cut) |
|  | Integrated LED 1344lm 2700°K 17W | Int. power supply 24V included  | Dimmable (phase cut) |
| <b>Airy 1614 L/P (1614 mm – 63.5")</b>   | LED intégrée 1536lm 2700°K 19W   | Alim. électronique 24V intégrée | Variable (phase cut) |
|  | Integrated LED 1536lm 2700°K 19W | Int. power supply 24V included  | Dimmable (phase cut) |

**Designer**

Émilie Cathelineau

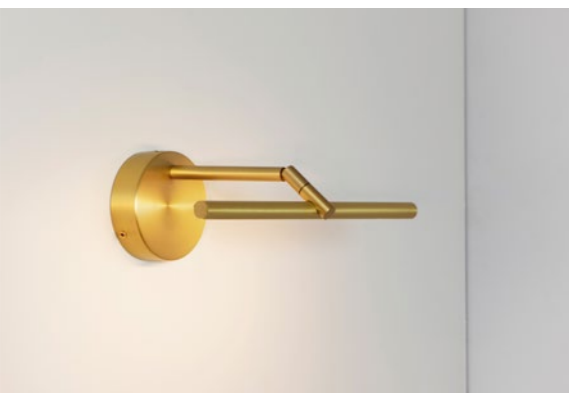

Airy R SB

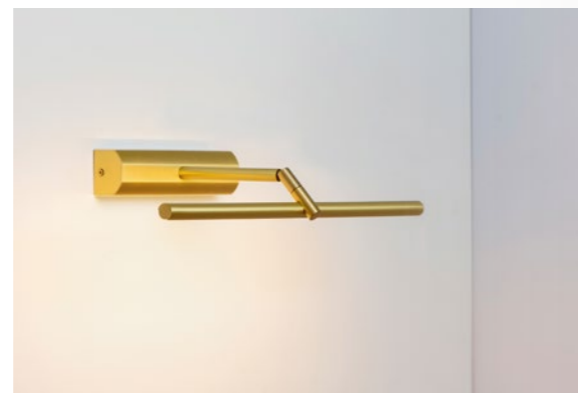

Airy L SB



Airy P SB

**Airy R Socle rond – Round base**

Uniquement de 214 à 1014 – Only from 214 to 1014

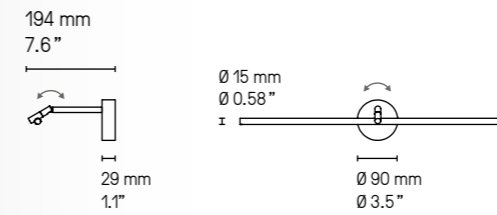

**Longueurs – Lengths**

214, 414, 514, 614, 814, 1014, 1214, 1414, 1614 mm  
Longueurs sur mesure possibles sur demande.  
Custom lengths available upon request.

**Airy L Socle long – Long base**

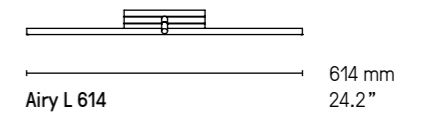
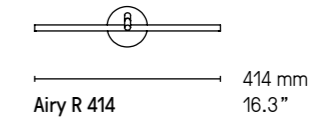
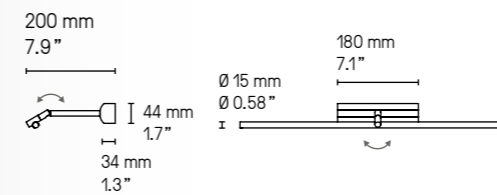

**Airy P Socle potence – Stem base**

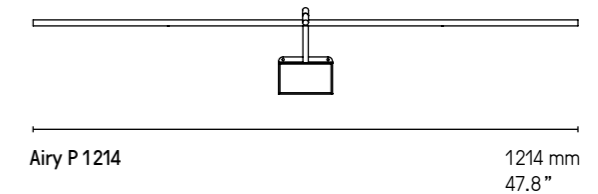
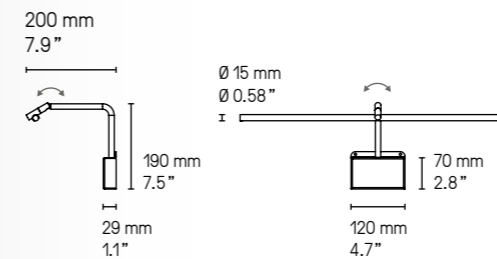



## ARBORESCENCE

La collection *Arborescence* s'inspire de la nature à travers une ligne organique et équilibrée: trois tubes de laiton cintrés qui maintiennent délicatement un abat-jour posé. Déclinée en lampadaires, suspensions, lampes et appliques, elle s'adapte à tous les espaces. La collection est également réalisable sur mesure pour des projets uniques.



The *Arborescence* collection draws inspiration from nature through an organic, balanced design: three curved brass tubes gently hold a shade in place. Available as floor lamps, pendants, table lamps and wall sconces, it adapts to all types of spaces. The collection can also be custom-made to create unique, project-specific pieces.

**Finitions**  
**Finishes**

Détails page 285

|                                    |   |                                     |                                     |                       |
|------------------------------------|---|-------------------------------------|-------------------------------------|-----------------------|
| ● Laiton satiné<br>SB Satin brass  | ● Graphite satiné<br>SG Satin graphite  | ● Nickel satiné<br>SN Satin nickel  | ● Cuivre satiné<br>SC Satin copper  | ● Bronze<br>BZ Bronze |
| ● Laiton poli<br>PB Polished brass | ● Graphite poli<br>PG Polished graphite | ● Nickel poli<br>PN Polished nickel | ● Cuivre poli<br>PC Polished copper |                       |

**Abat-jour**  
**Lampshade**

□ Drop Paper® 100    ■ Drop Paper® 101

**Matériaux**  
**Materials**

|  |  |   |
|--|--|---|
| Tous – All<br>Laiton massif<br>Solid Brass | Tous – All<br>Abat-jour Drop Paper® M1<br>Lampshade Drop Paper® M1 | <b>Lampes de table – Table lamps</b><br><b>Lampadaires – Floor lamps</b><br>Câble textile noir (longueur ≈ 2 m)<br>Black textile cable (length ≈ 78.7") |
|--|--|---|

**Source**  
**Lamping**

Suspensions – Pendants

**Suspensions – Pendant lights**

1 x E27 LED 20W max. non fournie

1 x E27 LED 20W max. not included

Ⓛ 1 x E26 type A 150W. Bulb not included

Variation\*

Dimming\*

Appliques – Wall lights

**Applique – Wall light XL**

1 x E27 LED 20W max. non fournie

1 x E27 LED 20W max. not included

1 x E26 type A 100W. Bulb not included

**Applique – Wall light XS**

1 x E27 LED 20W max. non fournie

1 x E27 LED 20W max. not included

1 x E26 type A 60W. Bulb not included

Variation\*

Dimming\*

**Lampe de table – Table lamp**

**Lampe de table – Table lamp**

1 x E27 LED 20W max. non fournie

1 x E27 LED 20W max. not included

Ⓛ 1 x E26 type A 100W. Bulb not included

Interrupteur sur câble

Cable switch

Cable switch

**Lampadaires – Floor lamps**

**Lampadaires – Floor lamps**

1 x E27 LED 20W max. non fournie

1 x E27 LED 20W max. not included

Ⓛ 1 x E26 type A 150W. Bulb not included

Variateur à pied

Foot operated dimmer

Foot operated switch

**Designer**

Hervé Langlais

\* Les luminaires variables nécessitent l'utilisation d'ampoules compatibles avec la variation.  
 All dimmable light fixtures require the use of compatible bulbs.

**Applique – Wall light XL**

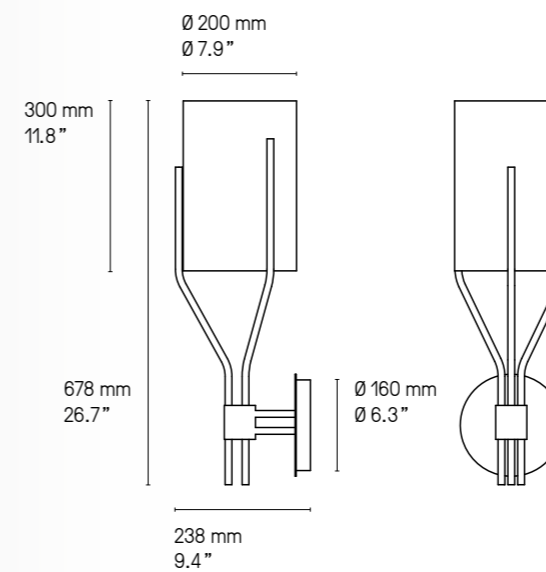

**Applique – Wall light XS**

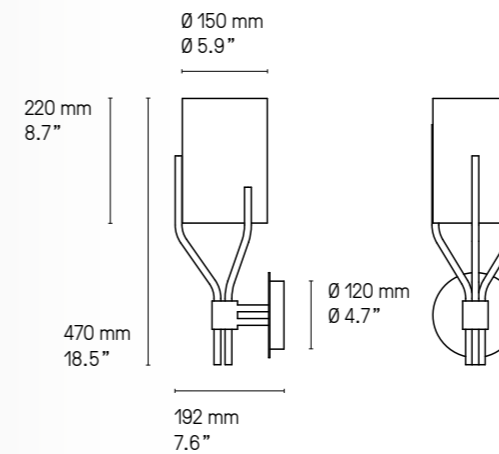

Applique – Wall light Arborescence XL SB



Lampe de table – Table lamp Arborescence SB

**Lampe de table – Table lamp**

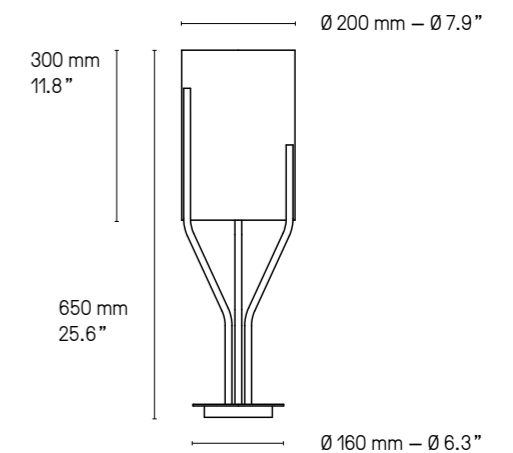

**Suspension – Pendant XXS**

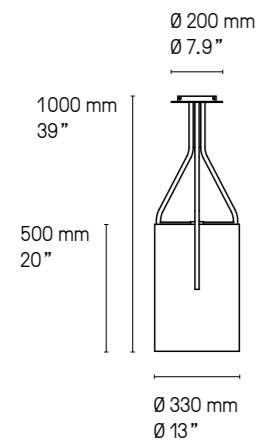

**Suspension – Pendant XS**

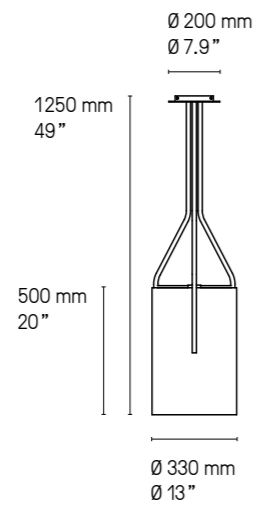

**Suspension – Pendant S**

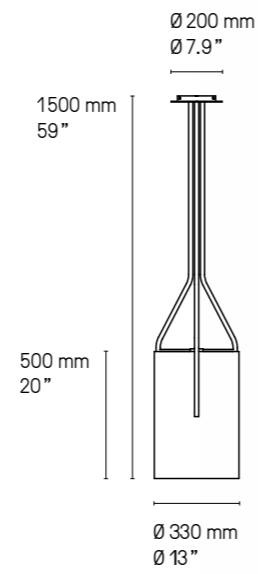

**Suspension – Pendant L**

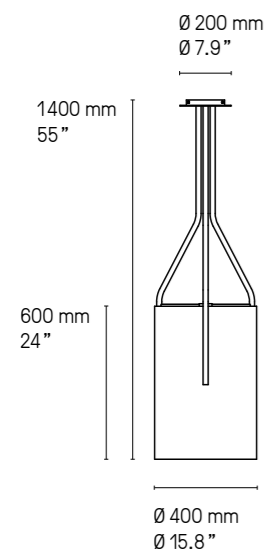

**Suspension – Pendant XL**

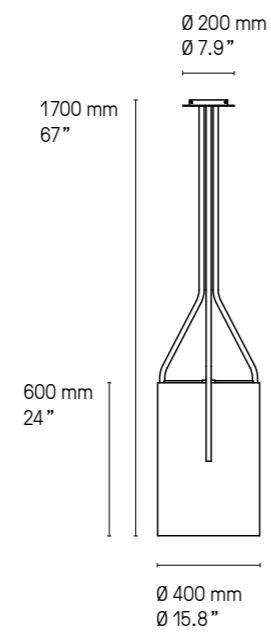

**Suspension – Pendant XXL**

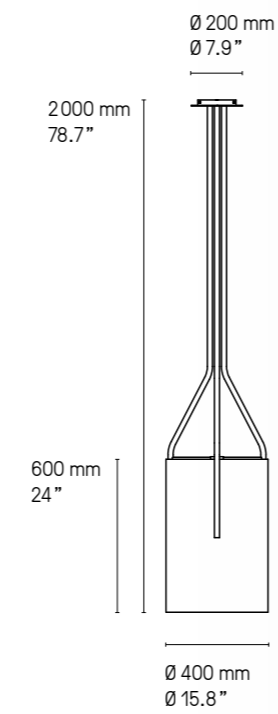

Hauteur sur mesure, versions LED et DALI sur demande.  
Custom heights, LED and DALI versions upon request.



Suspension – Pendant Arborescence XXS + XS + S PB



Lampadaire – Floor lamp **XXS**

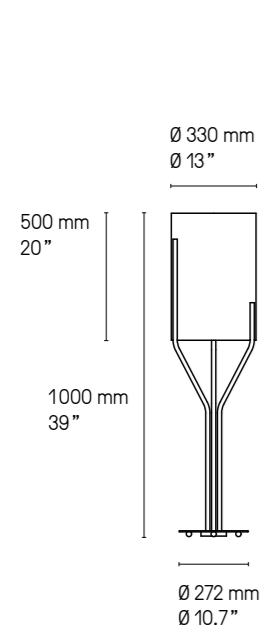

Lampadaire – Floor lamp **XS**

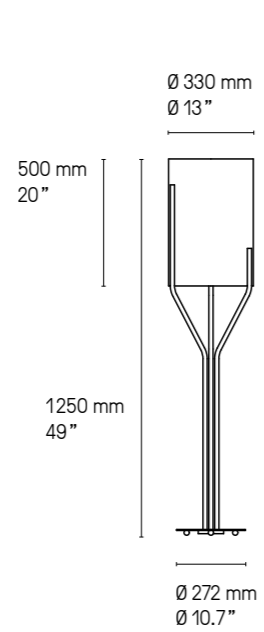

Lampadaire – Floor lamp **S**

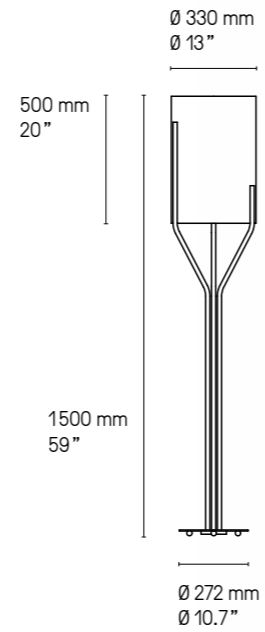

Lampadaire – Floor lamp **L**

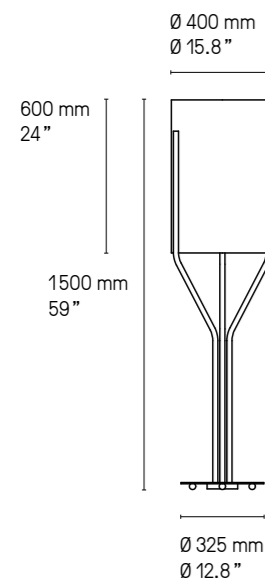

Lampadaire – Floor lamp **XL**

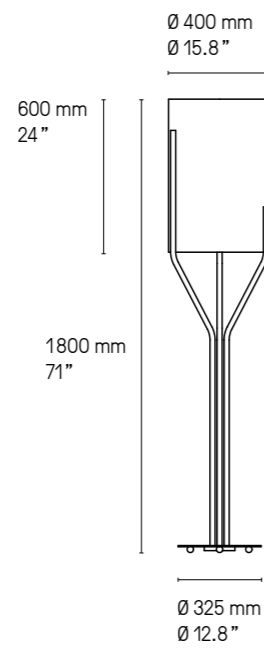

Lampadaire – Floor lamp **XXL**

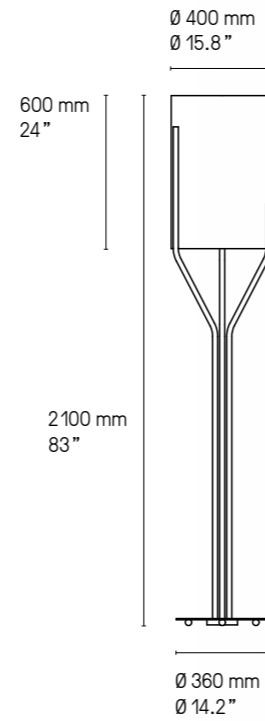

Hauteur sur mesure, versions LED et DALI sur demande.  
Custom heights, LED and DALI versions upon request.



Lampadaire – Floor lamp Arborescence XL + XXL + L SB



## ATMOS

Au centre de sa grande couronne ajourée, les disques concentriques d'*Atmos* se succèdent jusqu'à son cœur lumineux. Grande sœur de l'applique *Earth*, *Atmos* se distingue par sa grande taille et la multitude de combinaisons de décors possibles.



At the center of its large openwork crown, the concentric discs of *Atmos* follow one another up to its luminous heart. Big sister to the *Earth* wall lamp, *Atmos* is distinguished by its large size and the multitude of possible decor combinations.

**Finitions**  
**Finishes** ① + ② + ③ + ④

- Laiton satiné  
SB Satin brass
- Graphite satiné  
SG Satin graphite
- Nickel satiné  
SN Satin nickel
- Bronze  
BZ Bronze

Détails page 285

**Matériaux**  
**Materials** Laiton massif  
Solid brass

|   |                |         |         |      |                                  |                      |      |
|---|----------------|---------|---------|------|----------------------------------|----------------------|------|
| <b>Source</b>                                       | LED intégrée   | 1700 lm | 2700° K | 22 W | Alim. électronique 24 V intégrée | Variable (phase cut) |      |
| <b>Lamping</b>                                      | Integrated LED | 1700 lm | 2700° K | 22 W | Integrated 24 V power supply     | Dimmable (phase cut) |      |
| <small>Valeurs nominales<br/>Nominal values</small> | Integrated LED | 1700 lm | 2700° K | 25 W | Integrated 24 V power supply     | Dimmable (phase cut) | Damp |

**Designer** Émilie Cathelineau

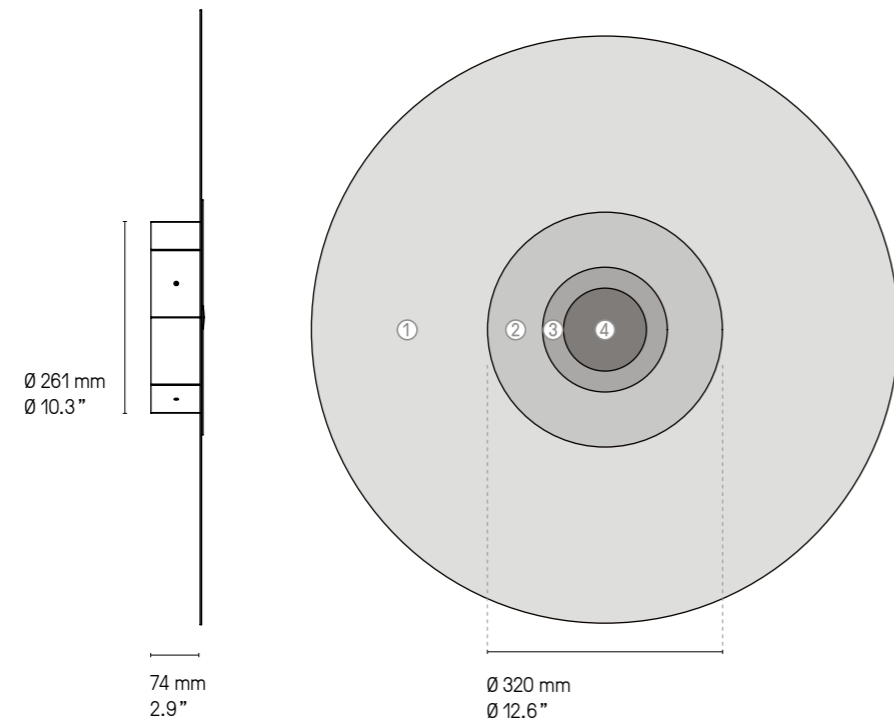

**Atmos Lace**

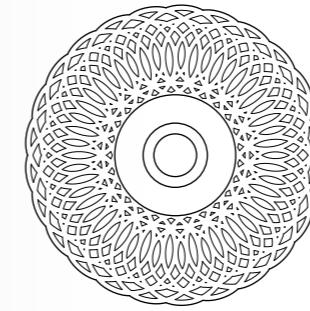

Ø 793 mm  
Ø 31.2"



Atmos Lace SB/SB/SG/SB

**Atmos Racine**

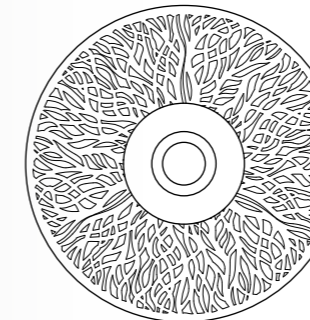

Ø 837 mm  
Ø 33"



Atmos Racine SB/SG/SG/SB



Atmos Racine SB/SG/SG/SB

### Atmos Pop

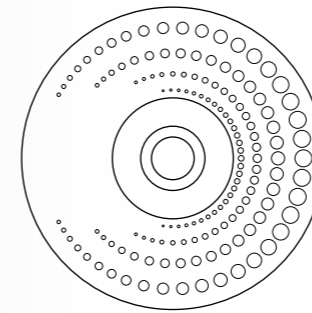

Ø 800 mm  
Ø 31.5"

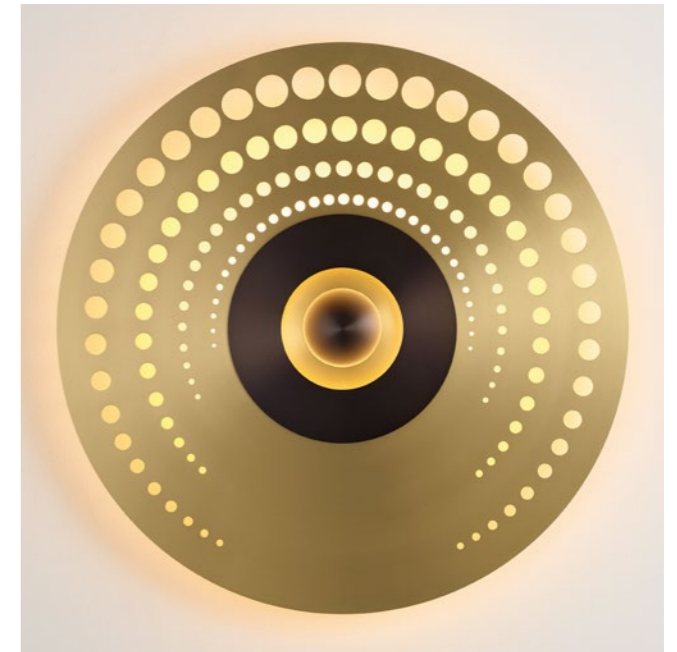

Atmos Pop SB/SG/SB/SG

### Atmos Stella

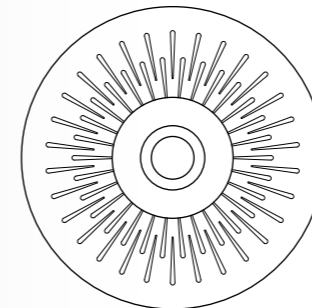

Ø 800 mm  
Ø 31.5"



Atmos Stella SG/SB/SG/SB



Atmos Éclat SB/SG/SB/SG



Atmos Éclat SG/SG/SB/SB

#### Atmos Éclat

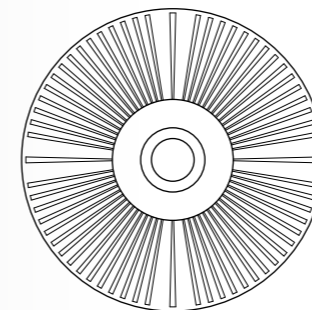

Ø 800 mm  
Ø 31.5"



Atmos Éclat SN/SG/SN/SN



## CALÉ(E)

Alphabet de formes, la collection *Calé(e)* se décline en jeu géométrique où le sens du déséquilibre forme des objets simples, linéaires et raffinés.





An assembly of designs, the *Calé(e)* collection offers a range of geometric patterns where the sense of imbalance forms simple, linear and sophisticated objects.





## Finitions Finishes





Détails page 285

### Suspensions, lampes de table, lampadaires – Pendants, table and floor lamps

|   |  |  |  |   |
|---|--|--|--|---|
|  Laiton satiné<br>SB Satin brass |  Graphite satiné<br>SG Satin graphite |  Nickel satiné<br>SN Satin nickel |  Cuivre satiné<br>SC Satin copper |  Bronze<br>BZ Bronze |
|---|--|--|--|---|

### Appliques – Wall mounted lights

|   |  |  |  |   |
|---|--|--|--|---|
|  Laiton satiné<br>SB Satin brass |  Graphite satiné<br>SG Satin graphite |  Nickel satiné<br>SN Satin nickel |  Cuivre satiné<br>SC Satin copper |  Bronze<br>BZ Bronze |
|---|--|--|--|---|

|  |   |   |   |
|--|---|---|---|
|  Laiton poli<br>PB Polished brass |  Graphite poli<br>PG Polished graphite |  Nickel poli<br>PN Polished nickel |  Cuivre poli<br>PC Polished copper |
|--|---|---|---|



## Abat-jour Lampshade

### Lampadaires, lampes de table – Table and floor lamps

|  |  |
|--|--|
|  Chinette noire<br>Black chinette |  Chinette blanche<br>White chinette |
|--|--|

## Câble Cable

### Suspensions – Pendants

|   |   |
|---|---|
|  Tissu noir<br>Black textile |  Tissu or (sur demande uniquement)<br>Gold textile (on request only) |
|---|---|

## Matériaux Materials

Tous – All  
Laiton massif  
Solid Brass

Suspensions, appliques, lampe XL  
Pendants, wall lights, table lamp XL  
Diffuseur en polycarbonate  
Polycarbonate diffuser

Lampe de table XS, lampadaires  
Table lamp XS, floor lamps  
Abat-jour en tissu  
Textile lampshade

Suspensions, lampes, lampadaires  
Pendants, table & floor lamps  
Câble textile (longueur ≈ 2 m)  
Textile cable (length ≈ 78.7")

*La longueur standard des câbles est de 2 m mais elle peut être diminuée à l'installation. Autres longueurs sur demande. The standard height of the cables is 2 m (78.7") but can be adjusted to less during installation. Custom heights available upon request.*

## Description Features

### Suspensions – Pendants

Il est possible de rassembler plusieurs suspensions sur un seul pavillon, circulaire ou rectangulaire. La version rectangulaire peut être adaptée à n'importe quelle longueur. La version circulaire a un diamètre maximum indiqué sur les croquis ci-après. Pour plus de renseignements, veuillez nous contacter.

It is possible to cluster several pendants from one single canopy, either rectangular or circular. The rectangular canopy can be custom-made into any size to suit your requirements. As for the circular canopy, available sizes are illustrated in the following pages. Please contact us for further information.

## Designer

POOL

## Source Lamping

Valeurs nominales  
Nominal values

### Suspensions – Pendants

#### Suspension – Pendant V1

|  |         |        |     |                             |                       |
|--|---------|--------|-----|-----------------------------|-----------------------|
| LED intégrée   | 1060 lm | 2700°K | 10W | Alim. électronique intégrée | Variation (phase cut) |
| Integrated LED   | 1060 lm | 2700°K | 10W | Int. power supply included  | Dimmable (phase cut)  |
|  Integrated LED | 500 lm  | 2700°K | 8W  | Int. power supply included  | Not dimmable          |

#### Suspension – Pendant V2

|  |         |        |     |                             |                       |
|--|---------|--------|-----|-----------------------------|-----------------------|
| LED intégrée   | 1050 lm | 2700°K | 11W | Alim. électronique intégrée | Variation (phase cut) |
| Integrated LED   | 1050 lm | 2700°K | 11W | Int. power supply included  | Dimmable (phase cut)  |
|  Integrated LED | 900 lm  | 2700°K | 12W | Int. power supply included  | Not dimmable          |

#### Suspension – Pendant V3

|  |         |        |     |                             |                       |
|--|---------|--------|-----|-----------------------------|-----------------------|
| LED intégrée   | 1060 lm | 2700°K | 10W | Alim. électronique intégrée | Variation (phase cut) |
| Integrated LED   | 1060 lm | 2700°K | 10W | Int. power supply included  | Dimmable (phase cut)  |
|  Integrated LED | 630 lm  | 2700°K | 9W  | Int. power supply included  | Not dimmable          |

#### Suspension – Pendant V4

|  |         |        |     |                             |                       |
|--|---------|--------|-----|-----------------------------|-----------------------|
| LED intégrée   | 1900 lm | 2700°K | 19W | Alim. électronique intégrée | Variation (phase cut) |
| Integrated LED   | 1900 lm | 2700°K | 19W | Int. power supply included  | Dimmable (phase cut)  |
|  Integrated LED | 1500 lm | 2700°K | 19W | Int. power supply included  | Not dimmable          |

#### Suspension – Pendant V5

|                |         |        |     |                             |                       |
|----------------|---------|--------|-----|-----------------------------|-----------------------|
| LED intégrée   | 1920 lm | 2700°K | 24W | Alim. électronique intégrée | Variation (phase cut) |
| Integrated LED | 1920 lm | 2700°K | 24W | Int. power supply included  | Dimmable (phase cut)  |

### Appliques – Wall lights

#### Appliques – Wall light VH, VV & VF

|                |        |        |     |                                 |                       |
|----------------|--------|--------|-----|---------------------------------|-----------------------|
| LED intégrée   | 960 lm | 2700°K | 10W | Alim. électronique 24V intégrée | Variation (phase cut) |
| Integrated LED | 960 lm | 2700°K | 10W | Int. power supply 24V included  | Dimmable (phase cut)  |

### Lampes de table – Table lamps

#### Lampe – Lamp XL

|                |         |        |     |                             |  |
|----------------|---------|--------|-----|-----------------------------|--|
| LED intégrée   | 1000 lm | 2700°K | 10W | Alim. électronique intégrée |  |
| Integrated LED | 1000 lm | 2700°K | 10W | Int. power supply included  |  |

#### Lampe – Lamp XS

|                                 |                        |
|---------------------------------|------------------------|
| 1X E14 LED 7W max. non fournie  | Interrupteur sur câble |
| 1X E14 LED 7W max. not included | Cable switch           |

### Lampadaires – Floor lamps

#### Lampadaires – Floor lamps XL

|                                  |                      |            |
|----------------------------------|----------------------|------------|
| 1X E27 LED 20W max. non fournie  | Variateur à pied     | Variation* |
| 1X E27 LED 20W max. not included | Foot operated dimmer | Dimming*   |

#### Lampadaires – Floor lamps XS

|                                  |                      |            |
|----------------------------------|----------------------|------------|
| 1X E27 LED 20W max. non fournie  | Variateur à pied     | Variation* |
| 1X E27 LED 20W max. not included | Foot operated dimmer | Dimming*   |

\* Les luminaires variables nécessitent l'utilisation d'ampoules compatibles avec la variation.  
All dimmable light fixtures require the use of compatible bulbs.

Suspensions – Pendants Calé(e) V5

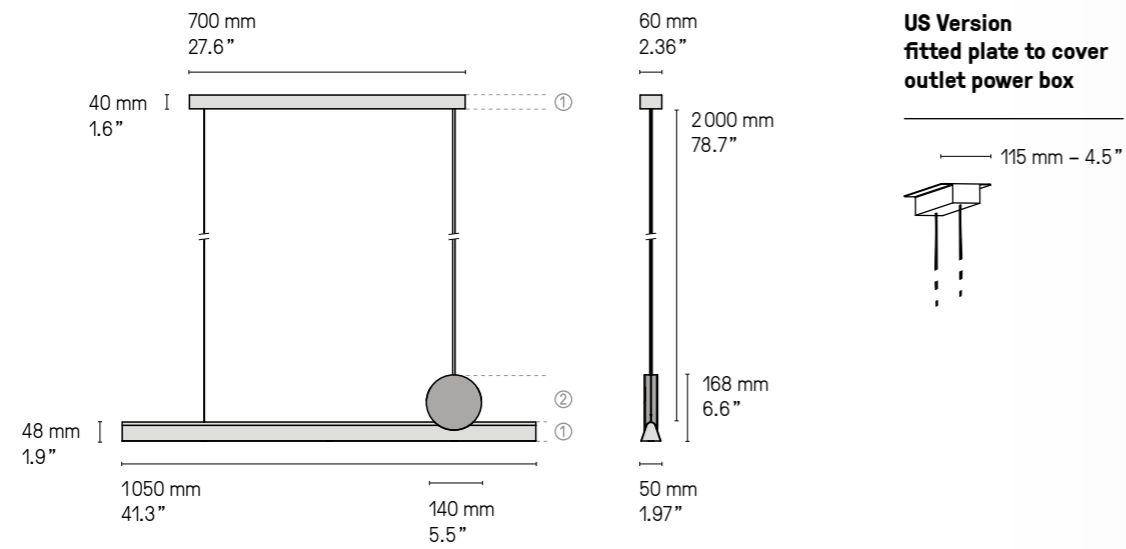

Calé(e) V5 SB/SG

La longueur standard des câbles est de 2 m mais elle peut être diminuée à l'installation. Autres longueurs sur demande.  
The standard height of the cables is 2 m (78.7") but can be adjusted to less during installation. Custom heights available upon request.



Calé(e) V5 SB/SG

Suspensions – Pendants Calé(e)

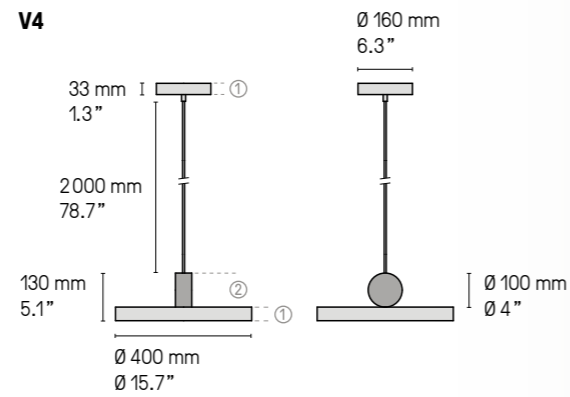
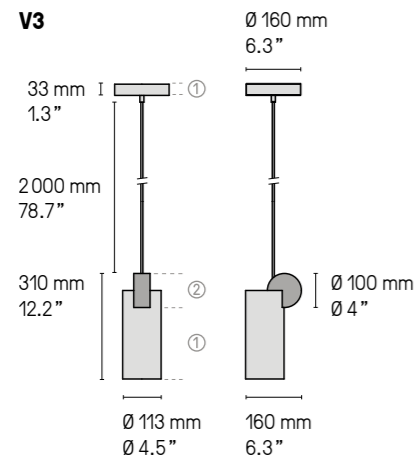
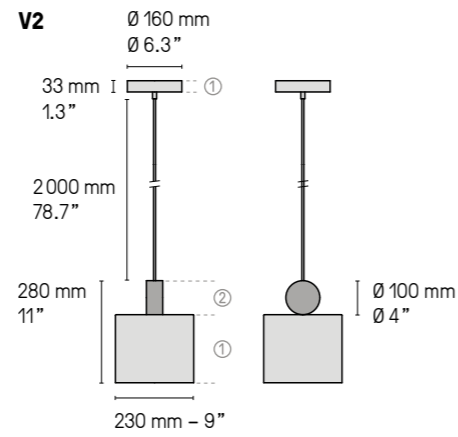
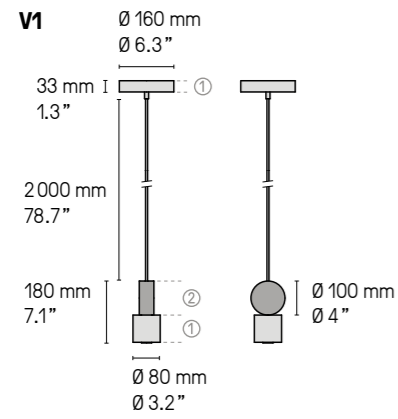

La longueur standard des câbles est de 2 m mais elle peut être diminuée à l'installation. Autres longueurs sur demande.  
 The standard height of the cables is 2 m (78.7") but can be adjusted to less during installation. Custom heights available upon request.

Le petit disque du dessous sera toujours en finition ①  
 The small centered disc on the bottom always comes in finish ①



Calé(e) V1 SB/SG  
 Installation sur mesure avec driver déporté.  
 Custom installation with remote driver.



Calé(e) V3 SG/SB

Suspensions – Pendants Calé(e)

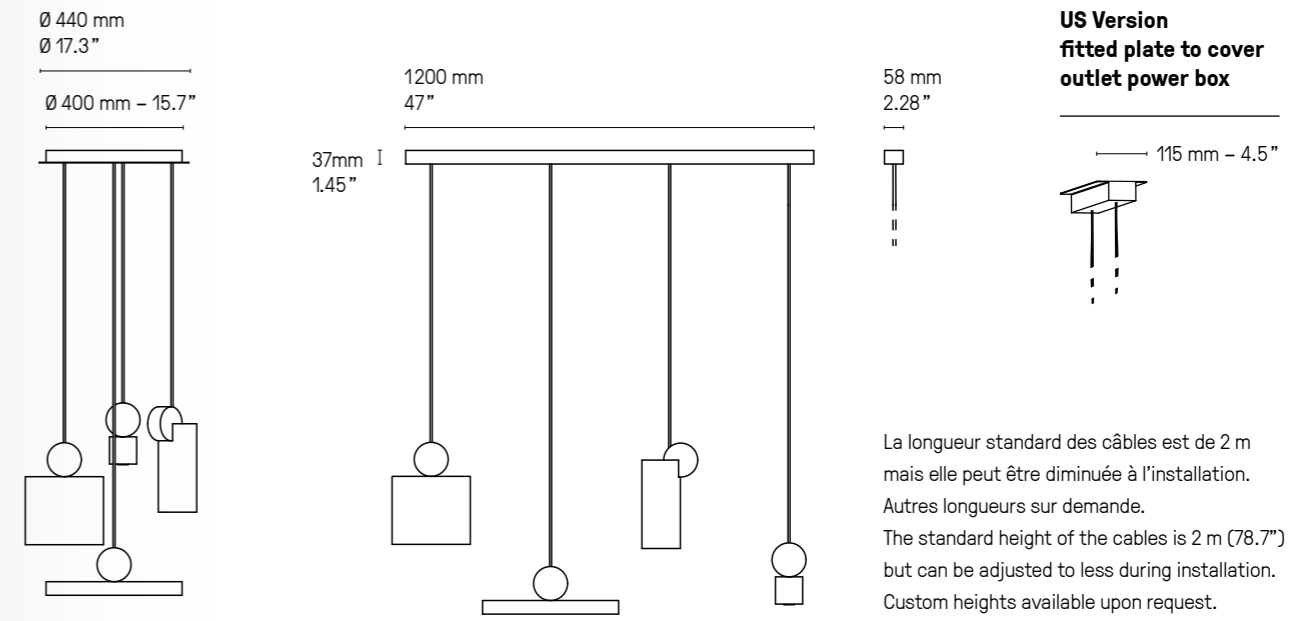

Calé(e) V3, V1, V2 & V4 SB/SG



Applique – Wall light Calé(e) VF SB/SG



Applique – Wall light Calé(e) VV SG/SB

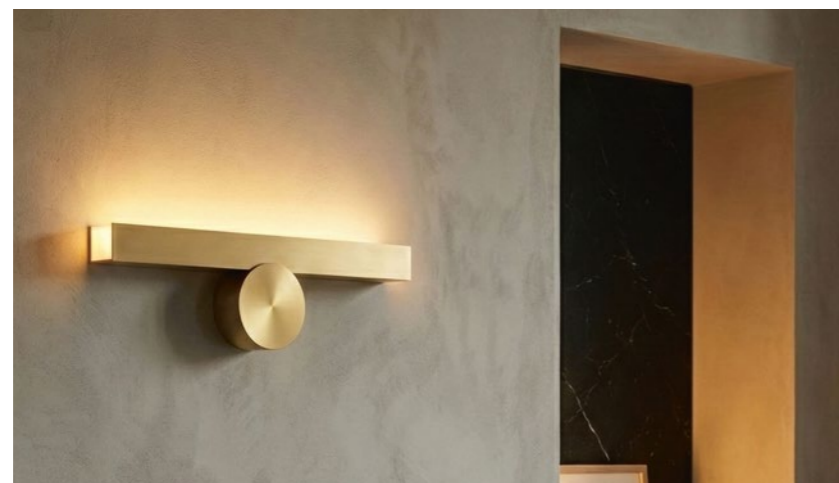

Applique – Wall light Calé(e) VH SB/SB

### Appliques – Wall lights Calé(e)

VH

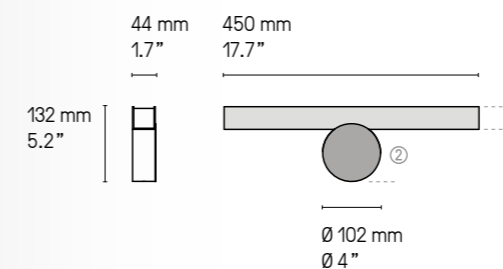

VV

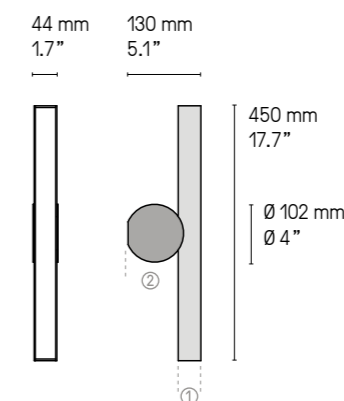

VF

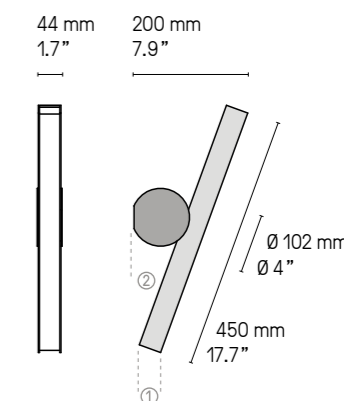

US Version  
fitted plate to cover outlet power box

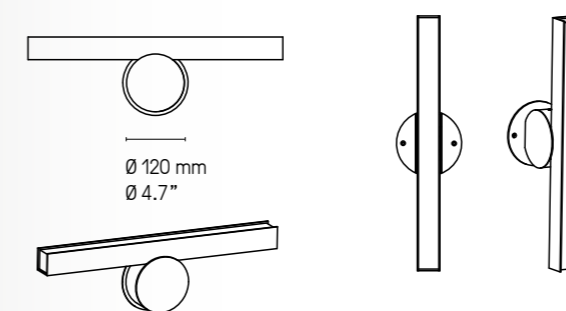

Applique – Wall light Calé(e) VF US Version SG/SB

Les appliques Calé(e)s ne sont pas réglables. Ce sont 3 modèles différents.  
Retrouvez les variantes salle de bain (IP44) de ces modèles p.259  
Calé(e) wall lights are not mobile. These are 3 different fixed models.  
You will find the bathroom variants (IP44) of these designs p.259

Lampes de table – Table lamps **Calé(e)**

**XL**

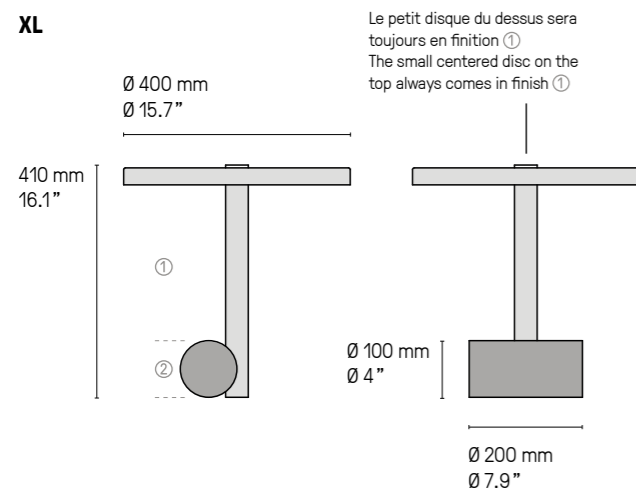

**XS**

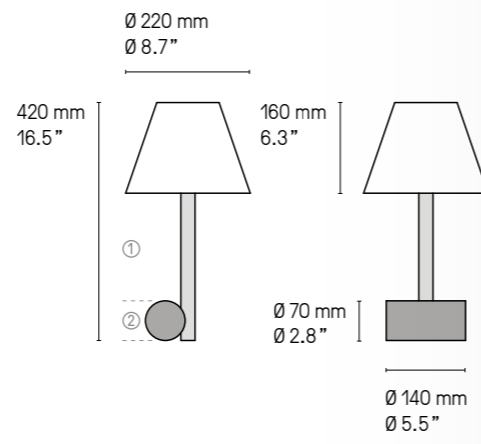

Lampe Calé(e) XS SB/SG



Lampe Calé(e) XS SB/SB





Lampadaire – Floor lamp Calé(e) XS SB/SB

Lampadaires – Floor lamp Calé(e)

**XL**

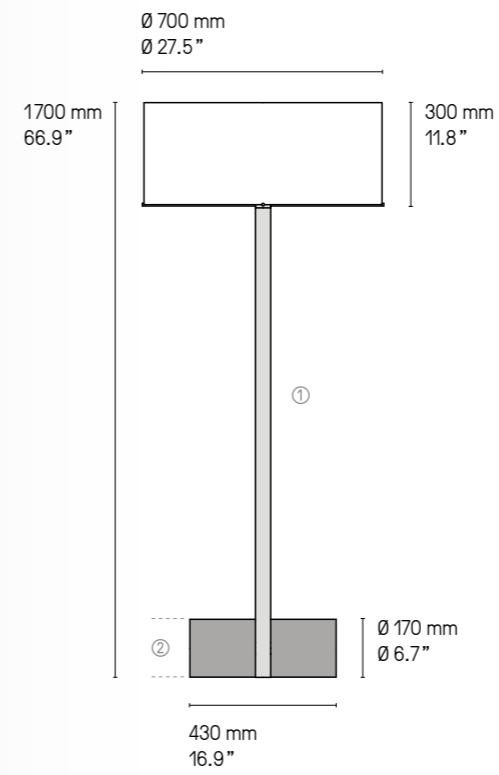

**XS**

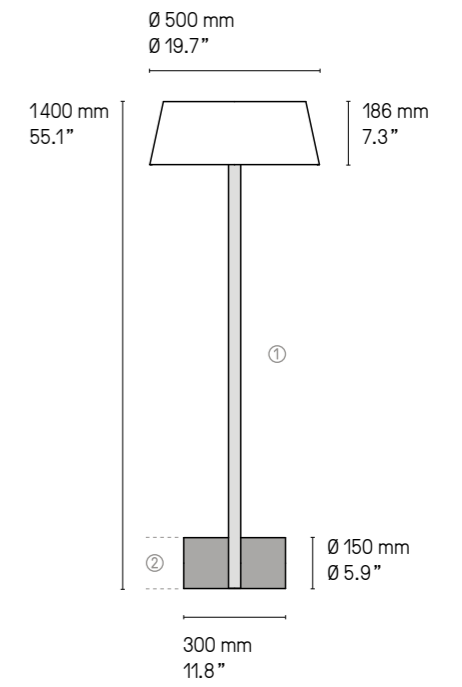

Version LED et DALI sur demande.  
LED and DALI version upon request.



Calé(e) XL SB/SG



## CANDY

La collection *Candy* a été conçue pour mettre en valeur le cœur du savoir-faire de CVL, soit le travail et la mise en forme du laiton sous forme de tubes. Les objets sont réduits à l'essentiel pour exprimer la pureté du métal et la précision des finitions caractéristiques de CVL. Cette apparente sobriété est subtilement complétée, voire contrebalancée, par un motif laqué en spirale qui s'enroule autour du tube tel un sucre d'orge.



The *Candy* collection was designed to showcase the core expertise of CVL: craftsmanship and the shaping of brass in tubular forms. Objects are reduced to their essence to express the purity of the metal and the precision of CVL's signature finishes. This apparent simplicity is subtly enhanced, or even counterbalanced, by a lacquered spiral pattern that wraps around the tube like a candy cane.

**Finitions  
Finishes**

- Laiton satiné / **SB** Satin brass
- Graphite satiné / **SG** Satin graphite
- Nickel satiné / **SN** Satin nickel
- Cuivre satiné / **SC** Satin copper

Détails page 285

**Abat-jour  
Lampshade**

- Chinette noire / Black chinette
- Chinette blanche / White chinette

**Matériaux  
Materials**

- Laiton massif / Solid brass or
- Abat-jour tissu / Textile lampshade
- Diffuseur polycarbonate / Polycarbonate diffuser
- Câble textile noir / Black textile cable

**Source  
Lamping**

*Valeurs nominales  
Nominal values*

**Suspensions – Pendants V30, V40 & V50**

- LED intégrée 331 lm 2700°K 2 W / Alimentation intégrée / Variation (phase cut)
- Integrated LED 331 lm 2700°K 2 W / Int. power supply included / Dimmable (phase cut)

**Applique – Wall light**

- LED intégrée 840 lm 2700°K 9W / Alimentation intégrée / Variation (phase cut)
- Integrated LED 840 lm 2700°K 9W / Int. power supply included / Dimmable (phase cut)

**Spot (not available for 110V)**

- LED intégrée 630 lm 2700°K 10W / Variation (phase cut)
- Integrated LED 630 lm 2700°K 10W / Dimmable (phase cut)

**Lampe de table – Table Lamp**

- E27 LED 20W max. non fournie / Interrupteur sur câble / Variation\*
- E27 LED 20W max. not included / Cable Switch / Dimmable\*
- E26 LED 20W max. not included / Cable Switch / Dimmable\*

**Lampadaire – Floor Lamp**

- E27 LED 20W max. non fournie / Variateur à pied / Variation\*
- E27 LED 20W max. not included / Foot operated dimmer / Dimmable\*
- E26 LED 20W max. not included / Foot operated dimmer / Dimmable\*

**Designer**

Jean-Baptiste Fastrez

\* Les luminaires variables nécessitent l'utilisation d'ampoules compatibles avec la variation.  
All dimmable light fixtures require the use of compatible bulbs.



Candy SB



Candy SG



Candy SN

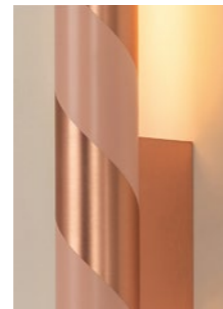

Candy SC

**Candy Suspensions – Pendants**

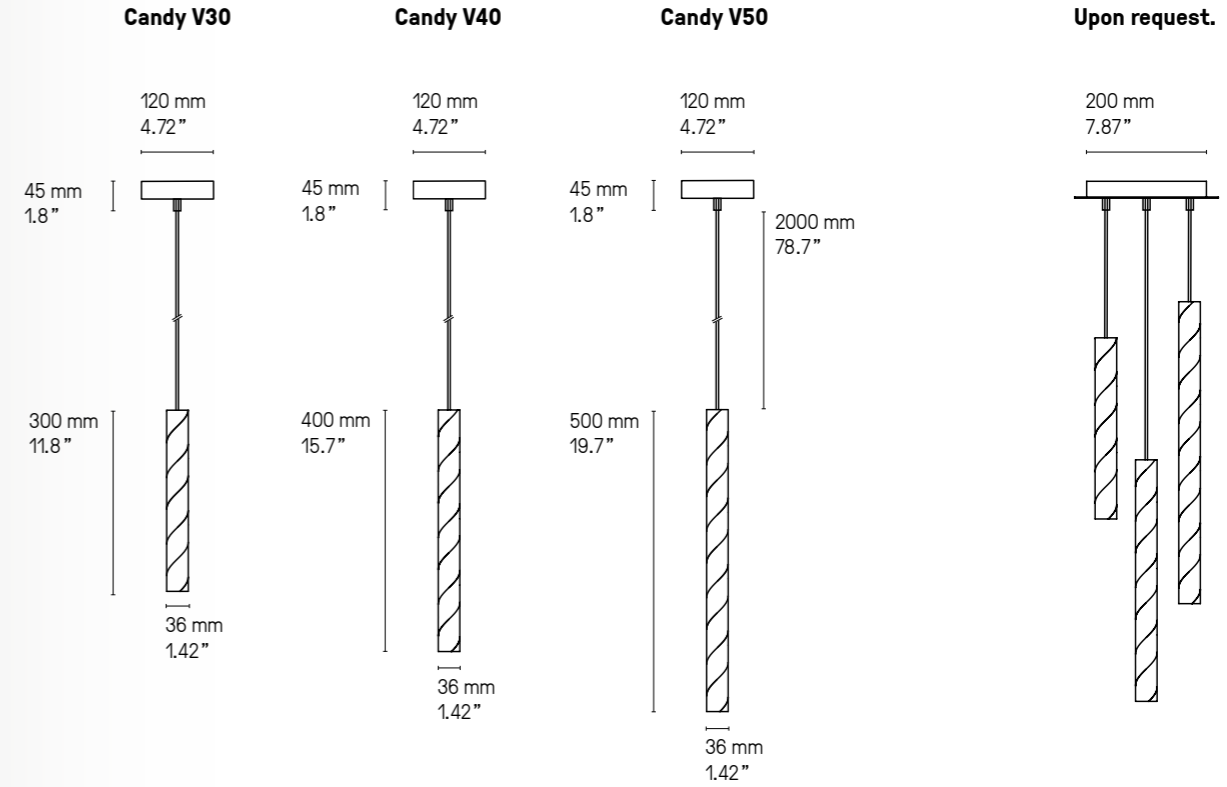

Candy V30 SG



Candy V40 SN



Candy V50 SB



Candy V40+V30+V50 SG

**Candy Applique- Wall light**

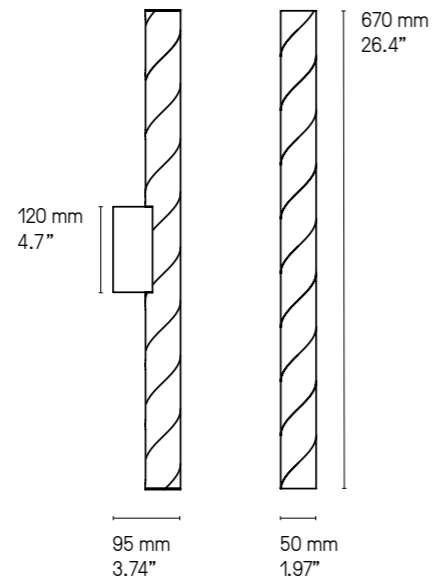

**US Version  
fitted plate to cover  
outlet power box**

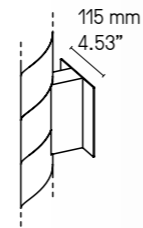

Candy Applique – Wall light SC

**Candy Spot ( not available in 110V)**

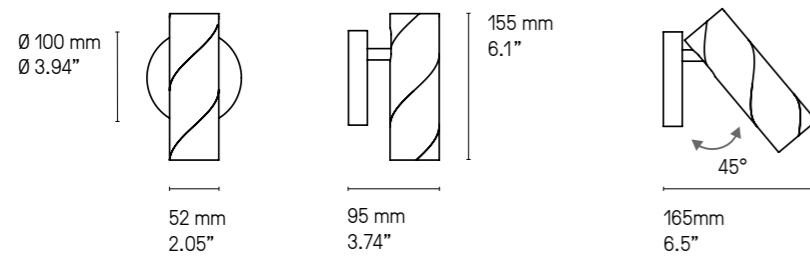

Candy Spot SG

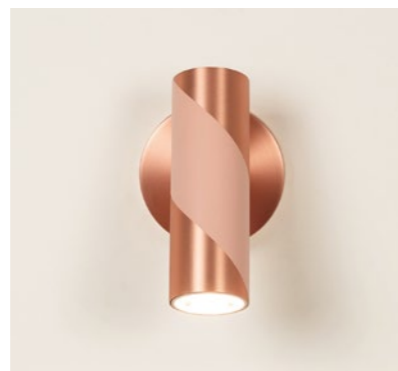

Candy Spot SC

**Candy Lampe – Lamp**

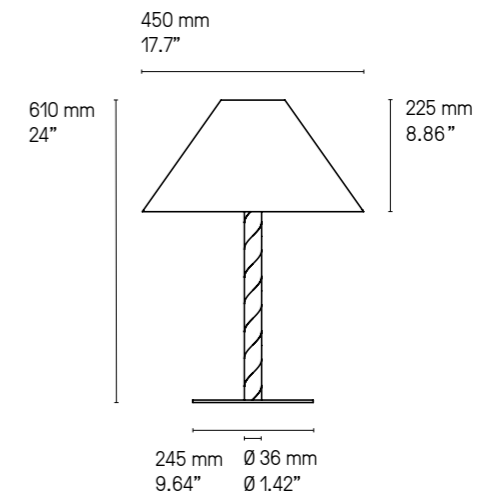

Candy Lampe – Lamp SB

**Candy Lampadaire- Floor lamp**

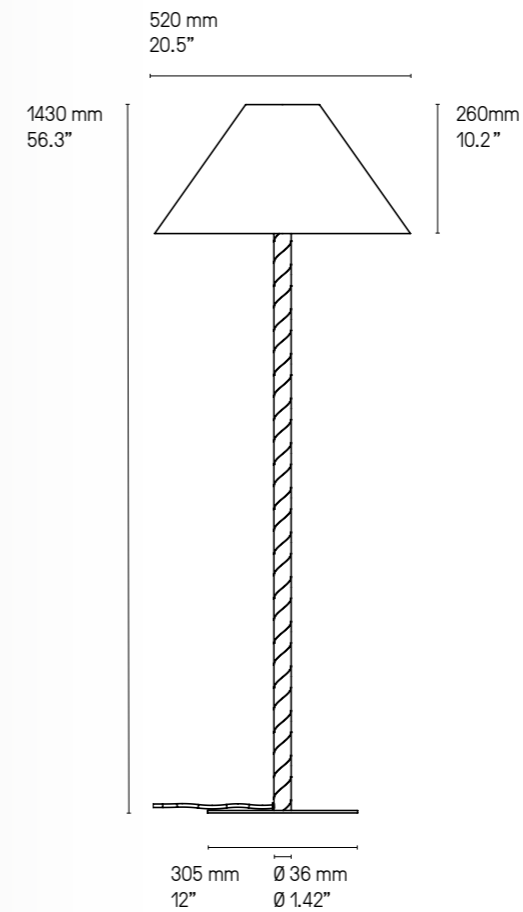

Candy Lampadaire – Floor lamp SB



## CARTA

Minimaliste et fonctionnelle, *Carta* s'impose par son design intemporel et sa finesse maîtrisée. Son tube lumineux pivote à 360° sans butée, offrant une liberté d'orientation infinie. Aguerrie à un usage intensif, elle incarne l'élégance durable selon CVL.



Minimalist and functional, *Carta* stands out for its timeless design and refined elegance. Its luminous tube rotates 360° without restriction, offering infinite freedom of orientation. Built to withstand intensive use, it embodies CVL's vision of lasting elegance.

**Finitions**  
**Finishes**

Détails page 285

|                                    |   |                                     |                                     |                       |
|------------------------------------|---|-------------------------------------|-------------------------------------|-----------------------|
| ● Laiton satiné<br>SB Satin brass  | ● Graphite satiné<br>SG Satin graphite  | ● Nickel satiné<br>SN Satin nickel  | ● Cuivre satiné<br>SC Satin copper  | ● Bronze<br>BZ Bronze |
| ● Laiton poli<br>PB Polished brass | ● Graphite poli<br>PG Polished graphite | ● Nickel poli<br>PN Polished nickel | ● Cuivre poli<br>PC Polished copper |                       |

**Matériaux**  
**Materials**

|                              |   |
|------------------------------|---|
| Laiton massif<br>Solid brass | Diffuseur polycarbonate<br>Polycarbonate diffuser |
|------------------------------|---|

**Source**  
**Lamping**

Valeurs nominales  
Nominal values

**Applique encastrée – Recessed wall light**

|                |        |        |    |                            |                     |
|----------------|--------|--------|----|----------------------------|---------------------|
| LED intégrée   | 144 lm | 2700°K | 2W | Alimentation intégrée      | Interrupteur ON/OFF |
| Integrated LED | 144 lm | 2700°K | 2W | Int. power supply included | Switch ON/OFF       |

**Applique encastrée + USB-C – Recessed wall light + USB-C**

|                |        |        |    |                            |                     |
|----------------|--------|--------|----|----------------------------|---------------------|
| LED intégrée   | 144 lm | 2700°K | 2W | Alimentation intégrée      | Interrupteur ON/OFF |
| Integrated LED | 144 lm | 2700°K | 2W | Int. power supply included | Switch ON/OFF       |

**Designer**

Éric Baron

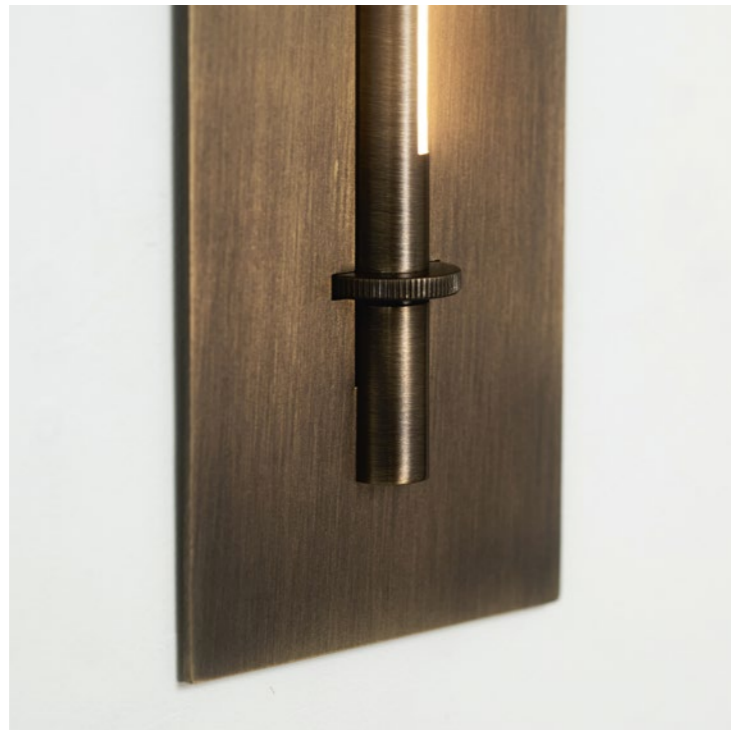

Détail Carta BZ

**CARTA 15**

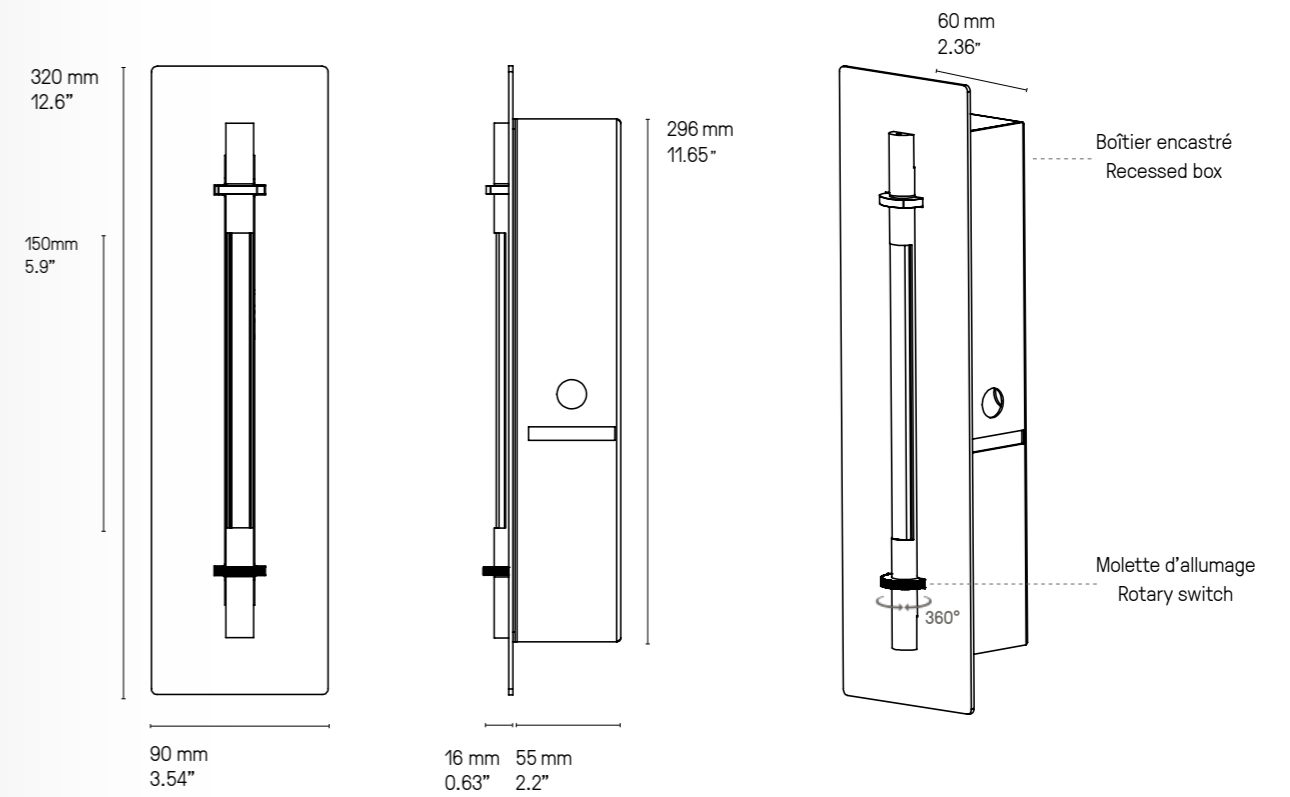

Carta 15 BZ



Carta 15 SN



Carta 15 SB



Carta + USB-C SN

**CARTA 15 + USB-C**

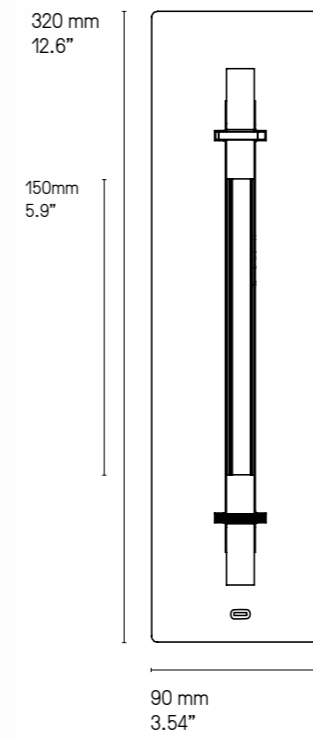

Carta + USB-C BZ

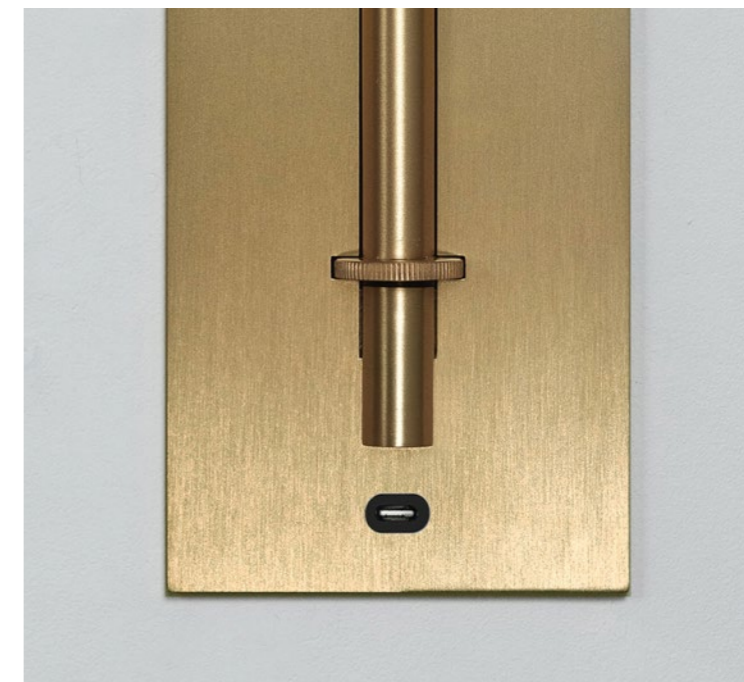

Détail Carta + USB-C SB



## CERCLE & TRAIT

D'une apparente légèreté, les formes de *Cercle & trait* se frottent et s'équilibrent dans un jeu de tension parfaitement maîtrisé. Désormais déclinée en collection complète – suspension, lampadaire, applique potence et liseuse sur pied – elle explore un langage graphique épuré, où la ligne et le cercle dialoguent avec finesse. Chaque pièce, disponible en différentes finitions, semble tenir en équilibre, comme suspendue à un fil.



As light as it looks, the forms of *Cercle & trait* rub together and hold together in a cleverly measured balance. Now developed into a complete collection – pendant, floor lamp, wall-mounted swing arm and reading lamp – it explores a refined graphic language where line and circle engage in a subtle dialogue. Each piece, available in a range of finishes, appears to exist in a delicate state of balance, as if suspended by a single thread.

**Finitions**  
**Finishes**

Détails page 285

|  |  |  |  |   |
|--|--|--|--|---|
| <span style="color: #D4AF37;">●</span> Laiton satiné | <span style="color: #000000;">●</span> Graphite satiné | <span style="color: #A9A9A9;">●</span> Nickel satiné | <span style="color: #C85135;">●</span> Cuivre satiné | <span style="color: #8B4513;">●</span> Bronze |
| SB Satin brass                                       | SG Satin graphite                                      | SN Satin nickel                                      | SC Satin copper                                      | BZ Bronze                                     |

**Matériaux**  
**Materials**

|  |  |   |
|--|--|---|
| <b>Tous – All</b><br>Laiton massif<br>Solid Brass  | <b>Tous – All</b><br>Diffuseur polycarbonate satiné<br>Satin Polycarbonate diffuser                          | <b>Potence applique – Deported wall light</b><br>Câble textile noir + câble métallique<br>Black textile cable + metal cable             |
|  | <b>Suspensions – Pendants</b><br>Câble textile noir (longueur ≈ 1 m)<br>Black textile cable (length ≈ 39.4") | <b>Lampadaire et liseuse – Floor and reading lamp</b><br>Câble textile noir + cordon élastomère<br>Black textile cable + elastomer cord |
| <i>La longueur standard des câbles est de 1 mètre mais elle peut être diminuée à l'installation.<br/>The standard height of the cables is 1 meter (39.4") but can be adjusted to less during installation.</i> |  |   |

**Source**  
**Lamping**

Valeurs nominales  
Nominal values

|   |                |         |        |                                      |                                      |                           |
|---|----------------|---------|--------|--------------------------------------|--------------------------------------|---------------------------|
| <b>Suspensions – Pendants</b>   |                |         |        |                                      |                                      |                           |
| <b>Suspension – Pendant XL</b>  |                |         |        |                                      |                                      |                           |
| LED intégrée  | 1350 lm        | 2700°K  | 16 W   | Alim. 24 V intégrée dans le pavillon | Variable (phase cut)                 |                           |
| Integrated LED  | 1350 lm        | 2700°K  | 16 W   | Int. power sup. 24 V incl. in canopy | Dimmable (phase cut)                 |                           |
|  | Integrated LED | 1350 lm | 2700°K | 19 W                                 | Int. power sup. 24 V incl. in canopy | Dimmable (phase cut) Damp |
| <b>Suspension – Pendant XS</b>  |                |         |        |                                      |                                      |                           |
| LED intégrée  | 930 lm         | 2700°K  | 12 W   | Alim. 24 V intégrée dans le pavillon | Variable (phase cut)                 |                           |
| Integrated LED  | 930 lm         | 2700°K  | 12 W   | Int. power sup. 24 V incl. in canopy | Dimmable (phase cut)                 |                           |
| <b>Potences murales – Deported wall lights</b>                                    |                |         |        |                                      |                                      |                           |
| <b>Potence murale – Deported wall light</b>                                       |                |         |        |                                      |                                      |                           |
| LED intégrée  | 1900 lm        | 2700°K  | 19 W   | Branchement avec prise               | Variateur à main                     |                           |
| Integrated LED  | 1900 lm        | 2700°K  | 19 W   | Plug-in connection                   | Hand operated dimmer                 |                           |
| <b>Potence murale – Deported wall light</b>                                       |                |         |        |                                      |                                      |                           |
| LED intégrée  | 1900 lm        | 2700°K  | 19 W   | Branchement mural                    | Variable (phase cut)                 |                           |
| Integrated LED  | 1900 lm        | 2700°K  | 19 W   | Main connection                      | Dimmable ( phase cut)                |                           |
| <b>Lampadaires – Floor lamps</b>  |                |         |        |                                      |                                      |                           |
| <b>Liseuse sur pied – Standing reading lamp</b>                                   |                |         |        |                                      |                                      |                           |
| LED intégrée  | 850 lm         | 2700°K  | 11 W   |                                      | Variateur à pied                     |                           |
| Integrated LED  | 850 lm         | 2700°K  | 11 W   |                                      | Foot operated dimmer                 |                           |
| <b>Lampadaire – Floor lamp</b>  |                |         |        |                                      |                                      |                           |
| LED intégrée  | 5400 lm        | 2700°K  | 36 W   |                                      | Variateur à pied                     |                           |
| Integrated LED  | 5400 lm        | 2700°K  | 36 W   |                                      | Foot operated dimmer                 |                           |

**Designer**

POOL

*Cercle & trait est un projet sur le mouvement des formes et l'équilibre qui s'entremêlent.  
Ce luminaire comme un mobile crée une lumière en mouvement.  
Cercle & trait is a design between movement of forms and balance that intertwine.  
Like a mobile this luminaire creates a light in motion.*



Cercle & trait XL SG

**Cercle & trait XL**

 UL version suitable for damp location

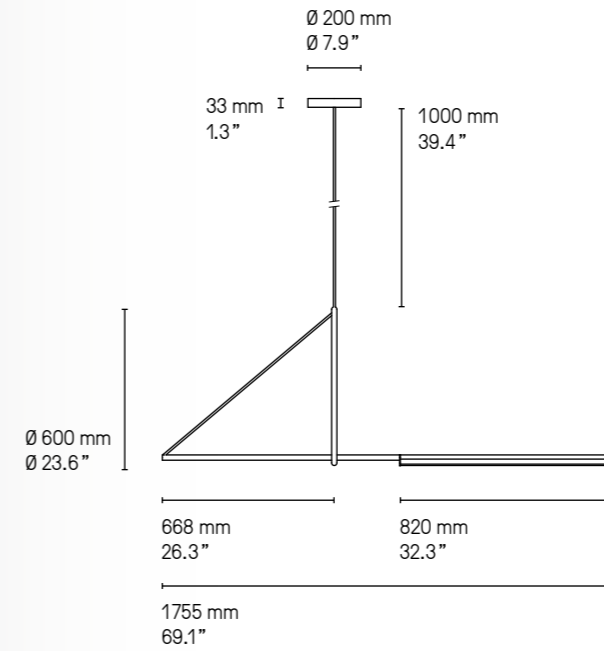

**Cercle & trait XS**

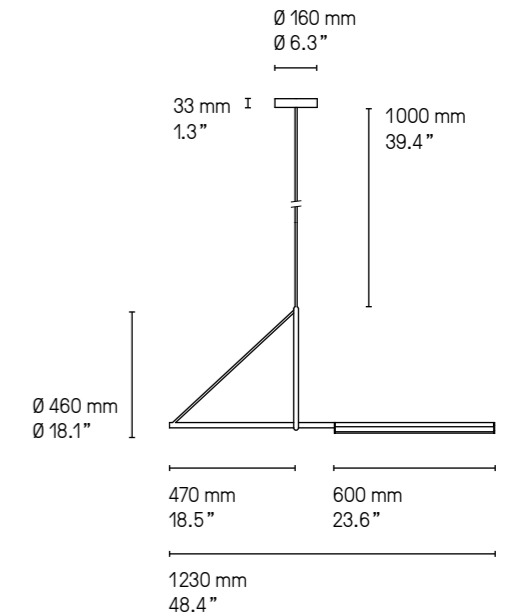

La longueur standard des câbles est de 1 m mais elle peut être diminuée à l'installation. Autres longueurs sur demande.  
The standard height of the cables is 1 m (39.4") but can be adjusted to less during installation. Custom heights available upon request.



**Cercle & trait Potence murale – Deported wall light**

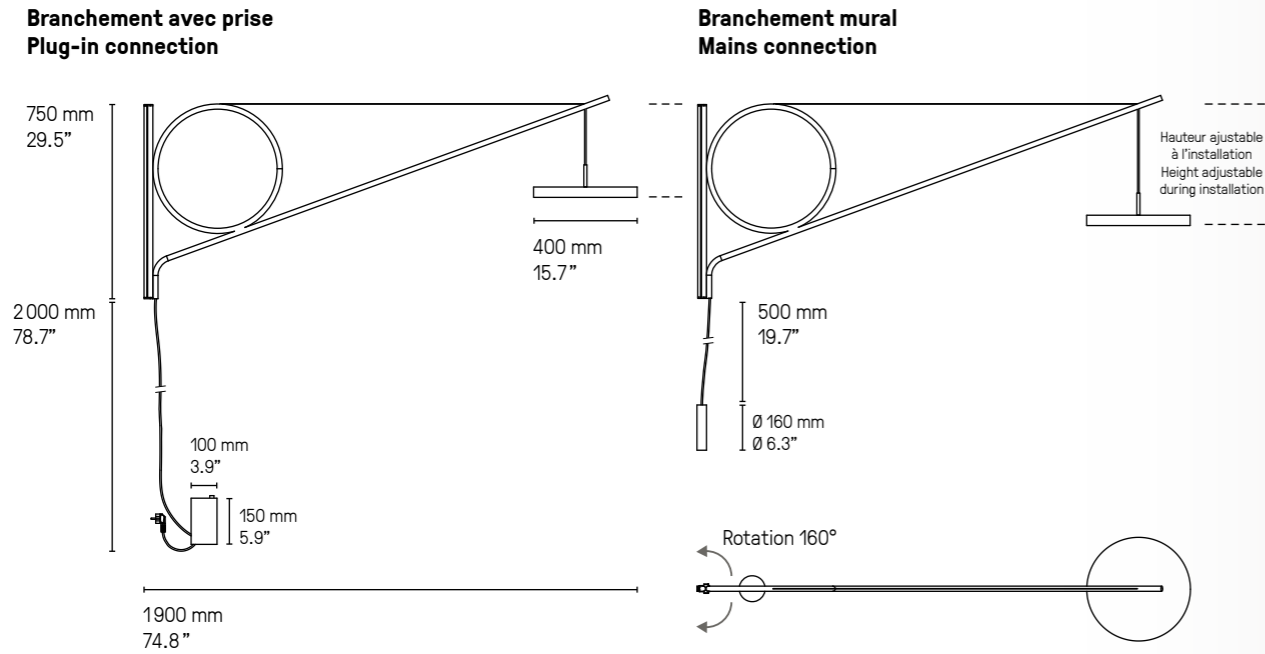

La longueur des câbles est ajustable à l'installation.  
The height of the cables can be adjusted during installation.



Cercle & trait Potence murale prise – Deported light plug-in SB

**Cercle & trait Liseuse sur pied – Standing reading lamp**

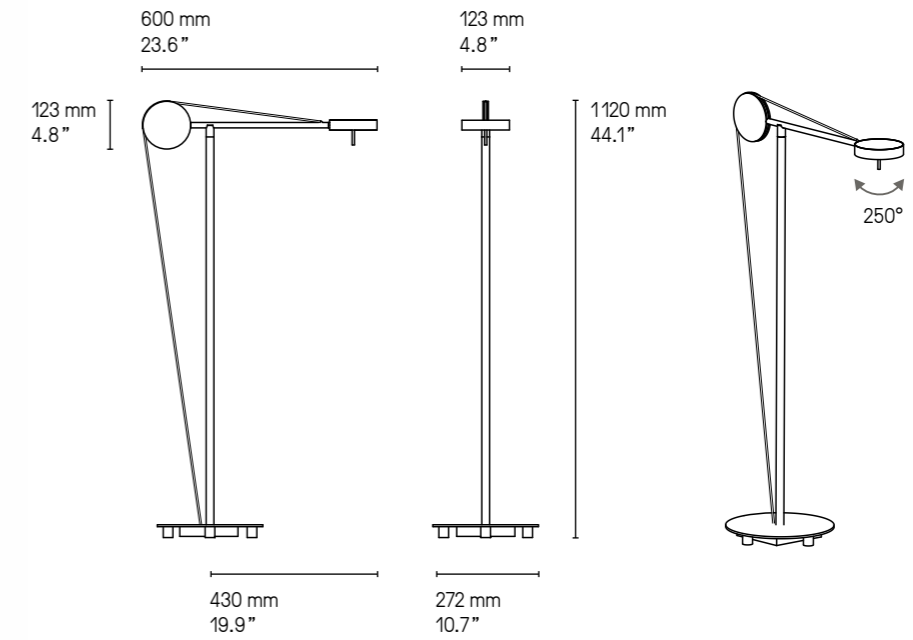



Cercle & trait Liseuse sur pied – Standing reading lamp SG

Cercle & trait Lampadaire – Floor lamp

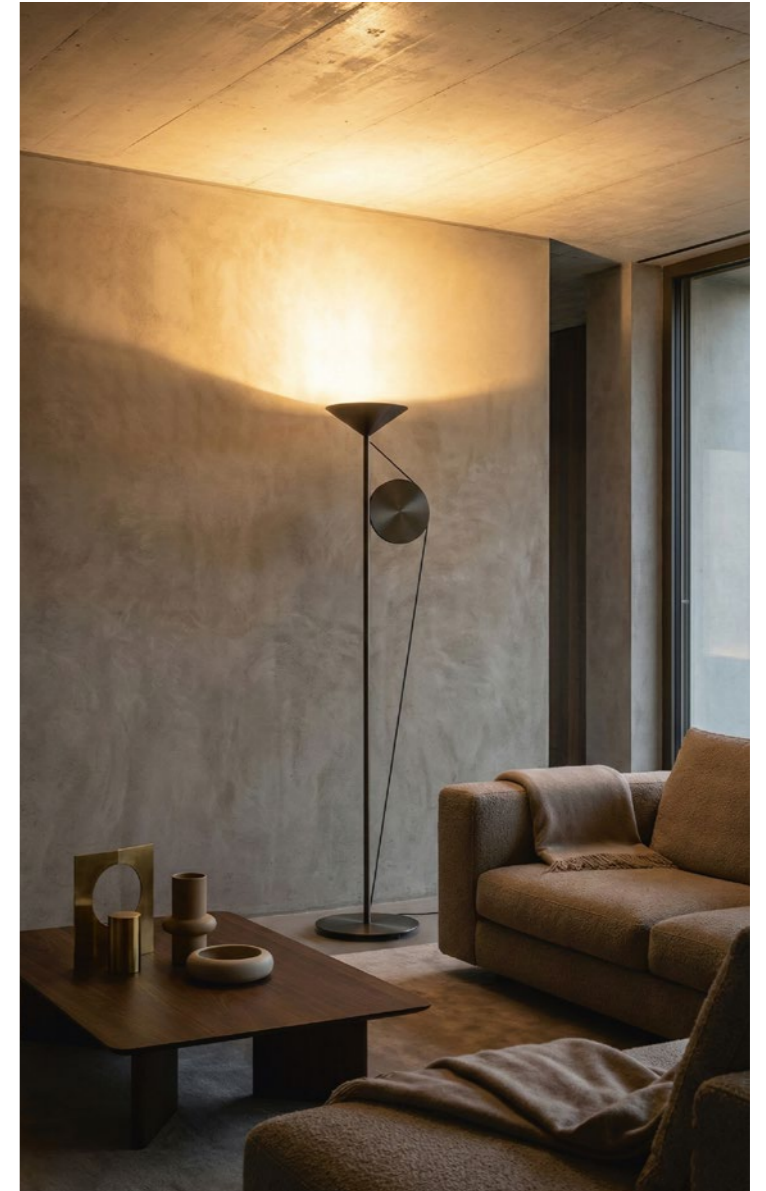
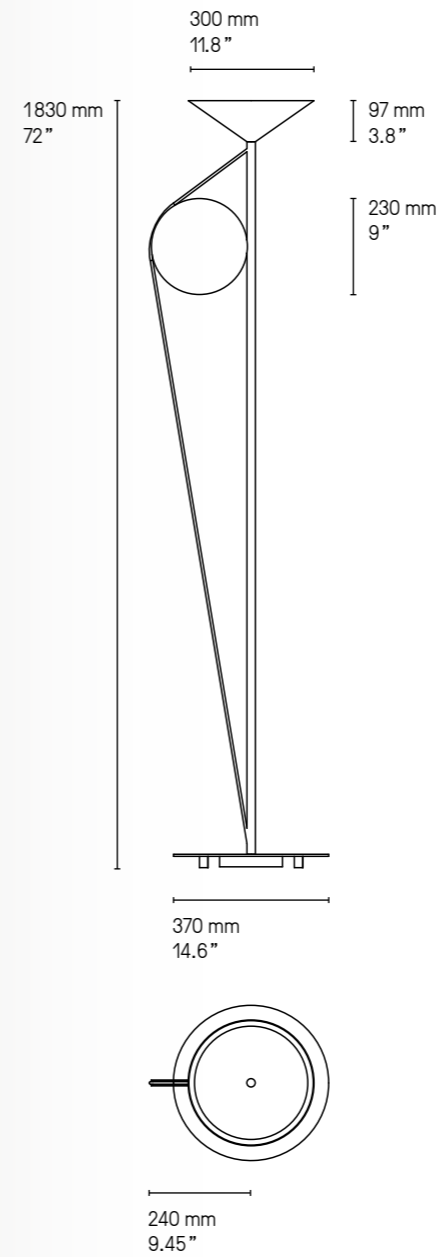

Cercle & trait Lampadaire – Floor lamp SG



## LES CLOPES

*Les Clopes* se compose de lampadaires et lampes à poser. Leur nom transgressif mais souriant, emblématique de l'esprit d'un créateur jonglant habilement entre les références à la culture populaire et celles de l'excellence, provient de leur longue forme élancée en tube.



*Les Clopes* consists of floor lamps and table lamps. Their transgressive yet cheerful name, emblematic of the spirit of a designer skillfully juggling references to popular culture with those of excellence, comes from their long, slender tube shape.

**Finitions**  
**Finishes**

Détails page 285

|  |   |  |
|--|---|--|
| ● Laiton satiné<br><b>SB</b> Satin brass | ● Bois brûlé<br><b>BW</b> Burnt wood      | ● Bois toasté<br><b>TW</b> Toasted wood  |
| ● Laque noire<br><b>NO</b> Glossy black  | ● Laque blanche<br><b>BC</b> Glossy white | <i>Bois uniquement pour lampadaire.<br/>Wood finishes only for floor lamp.</i> |

**Finitions**  
**Finishes**

|   |  |  |
|---|--|--|
| ● Laiton poli<br><b>PB</b> Polished brass | ● Graphite poli<br><b>PG</b> Polished graphite | ● Nickel poli<br><b>PN</b> Polished nickel |
|---|--|--|

**Matériaux**  
**Materials**

|   |                                  |   |
|---|----------------------------------|---|
| Laiton massif ou/et Frêne massif<br>Solid brass or/and Ash wood | Abat-jour lin<br>Linen lampshade | Câble textile noir<br>Black textile cable |
|---|----------------------------------|---|

**Source**  
**Lamping**

*Valeurs nominales  
Nominal values*

**Suspensions – Pendants**

|                      |          |         |      |
|----------------------|----------|---------|------|
| <b>Clopes 20-145</b> |          |         |      |
| LED intégrée         | 3 420 lm | 2 700°K | 30 W |
| Integrated LED       | 3 420 lm | 2 700°K | 30 W |
| <b>Clopes 20-100</b> |          |         |      |
| LED intégrée         | 2 320 lm | 2 700°K | 20 W |
| Integrated LED       | 2 320 lm | 2 700°K | 20 W |

**Lampadaires – Floor lamps**

|                      |          |         |      |
|----------------------|----------|---------|------|
| <b>Clopes 09-40</b>  |          |         |      |
| LED intégrée         | 855 lm   | 2 700°K | 8 W  |
| Integrated LED       | 855 lm   | 2 700°K | 8 W  |
| <b>Clopes 09-80</b>  |          |         |      |
| LED intégrée         | 1 830 lm | 2 700°K | 16 W |
| Integrated LED       | 1 830 lm | 2 700°K | 16 W |
| <b>Clopes 14-70</b>  |          |         |      |
| LED intégrée         | 1 590 lm | 2 700°K | 14 W |
| Integrated LED       | 1 590 lm | 2 700°K | 14 W |
| <b>Clopes 14-100</b> |          |         |      |
| LED intégrée         | 2 320 lm | 2 700°K | 20 W |
| Integrated LED       | 2 320 lm | 2 700°K | 20 W |
| <b>Clopes 20-100</b> |          |         |      |
| LED intégrée         | 2 320 lm | 2 700°K | 20 W |
| Integrated LED       | 2 320 lm | 2 700°K | 20 W |
| <b>Clopes 20-145</b> |          |         |      |
| LED intégrée         | 3 420 lm | 2 700°K | 30 W |
| Integrated LED       | 3 420 lm | 2 700°K | 30 W |

**Designer**

José Lévy



Clopes SB/PB, BW/PG and TW/PG

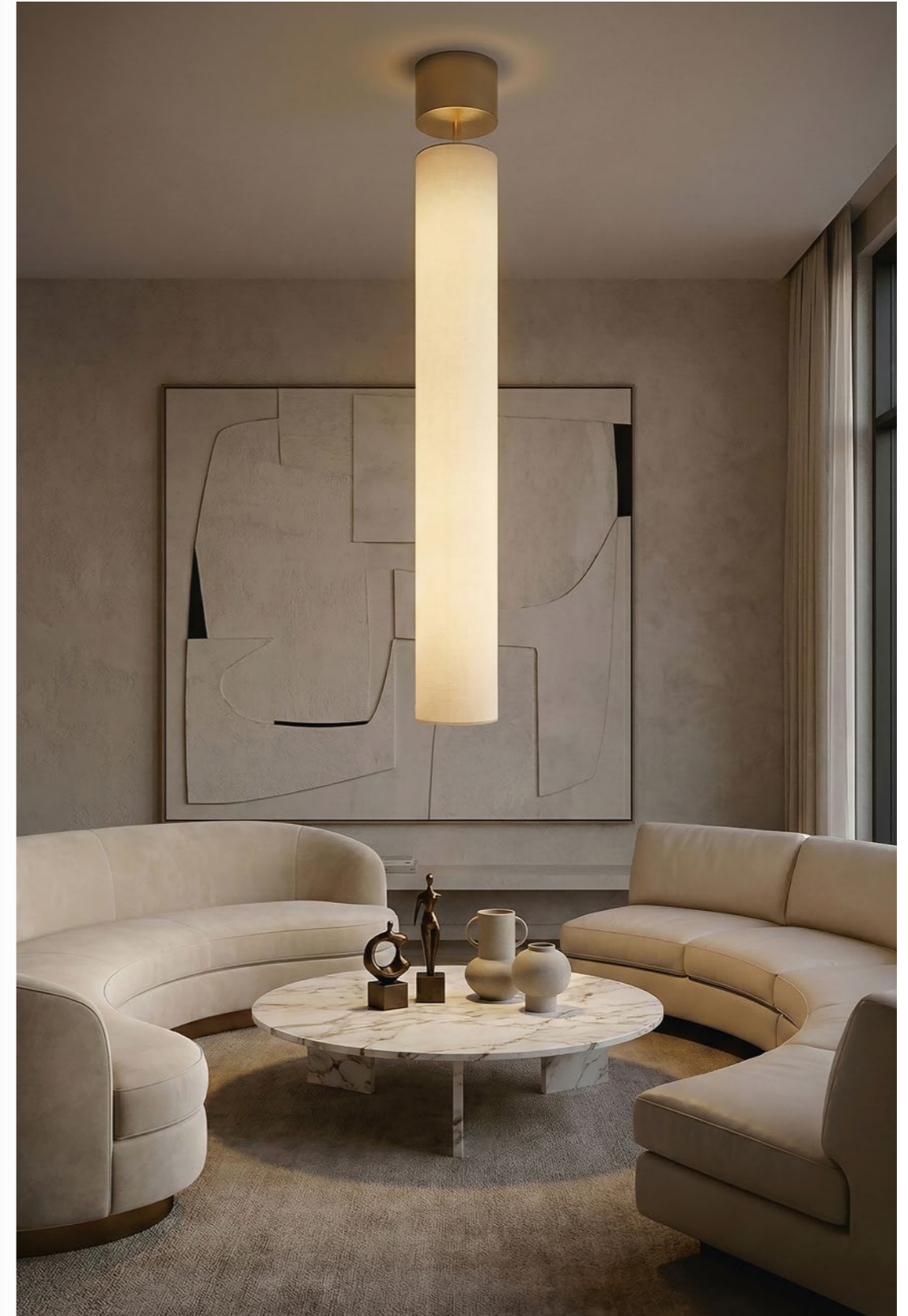

Clopes Suspension 20-145 SB

Suspensions – Pendants

Clope 20-145

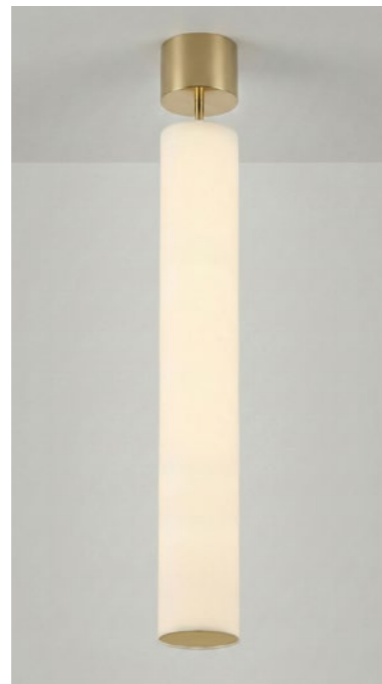
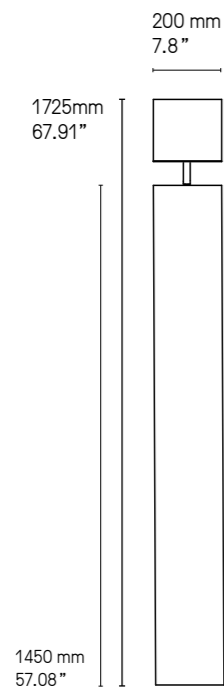

Clopes Suspension 20-145 SB

Clope 20-100

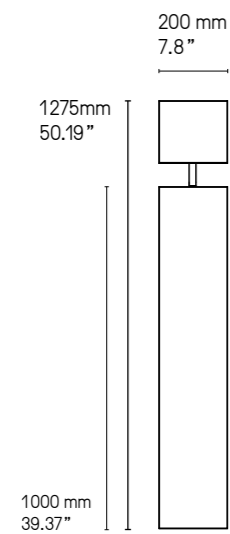

Clopes Suspension 20-100 SB

Lampadaires – Floor lamp

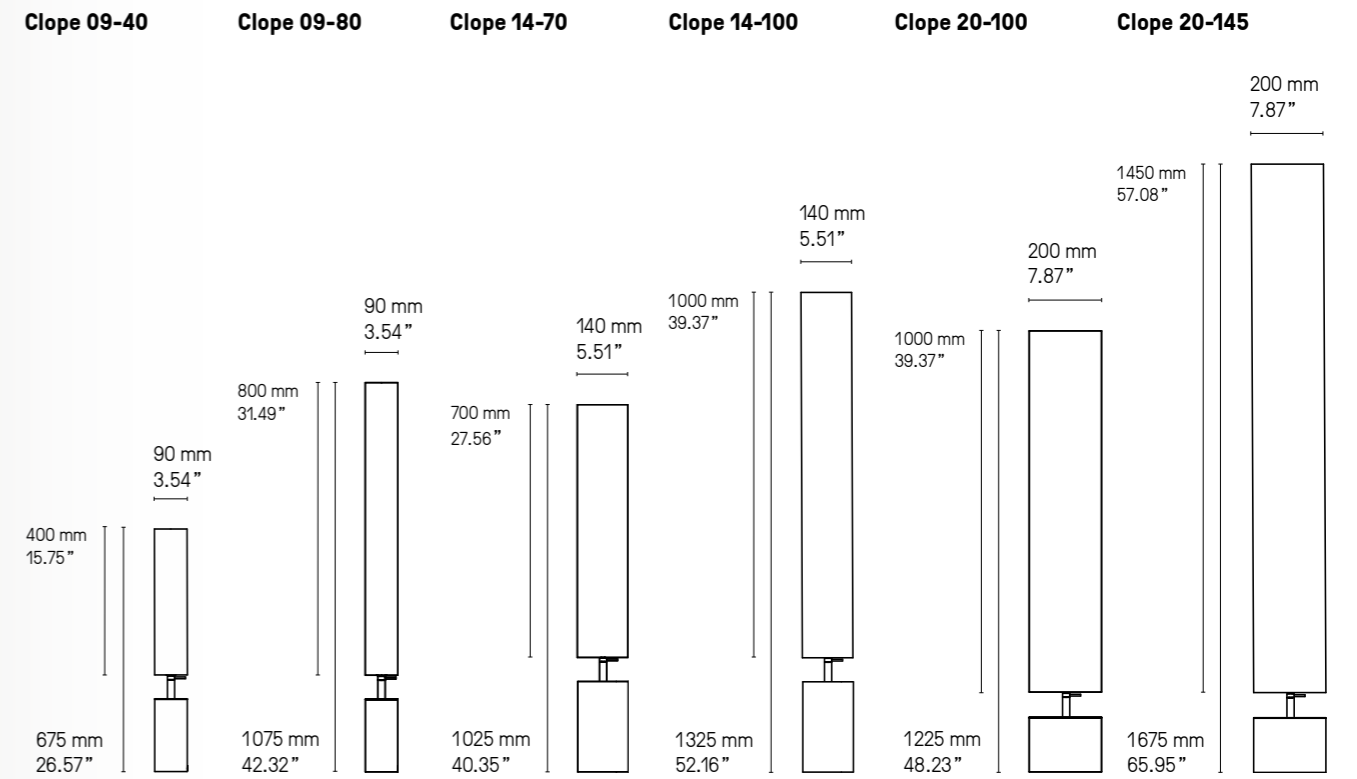

Finitions  
Finishes

Le lampadaire *Clopes* peut être inclinée vers la droite ou la gauche.  
*Clopes* floor lamp can be tilted to the right or the left.

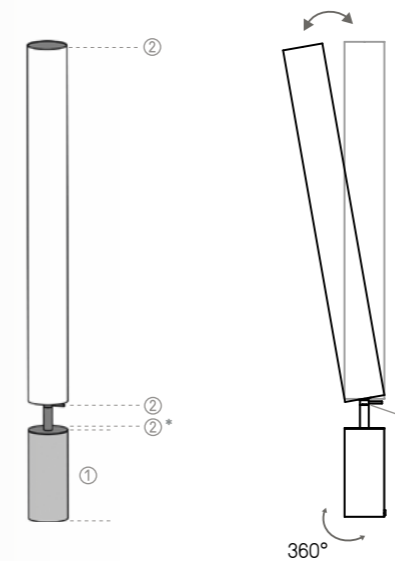

\*Sauf pour finitions BC & NO = ①  
 Except for BC & NO finishes = ①

\*Desserrer pour incliner l'abat-jour  
 Loosen to tilt the shade



Clopes 09-80 SB/PB, 14-70 TW/PG & 9-40 NO/PN



Clopes 20-100 TW/PG & 14-100 BW/PG



Clopes 20-100 SB/PB & 09-80 SB/PB



## LES CO

Avec leur corps et leur tête cylindriques et minimalistes, la série des *Co* est celle qui reflète avec le plus de fidélité l'inspiration des « Kokeshis » de la collection « *Clopes and Co* » de José Lévy. Cette famille de lampes à poser, de différentes tailles, est constituée de bois ou de métal et la partie supérieure, de verre opale.



With their minimalist, cylindrical bodies and heads, *Les Co* series is the one that most faithfully reflects the inspiration of the “Kokeshis” in the « *Clopes and Co* » collection by José Lévy. This family of table lamps, in various sizes, is made of wood or metal, with the upper part in opal glass.

|   |  |  |   |
|---|--|--|---|
| <b>Finitions</b><br><b>Finishes</b> ①   | ● Laiton satiné<br>SB Satin brass  | ● Bois brûlé<br>BW Burnt wood  | ● Bois toasté<br>TW Toasted wood          |
|   | ● Laiton poli<br>PB Polished brass   | ● Graphite poli<br>PG Polished graphite                              | ● Nickel poli<br>PN Polished nickel       |
| <b>Finitions</b><br><b>Finishes</b> ②   | ● Laque Noire<br>NO Glossy black   | ● Laque Blanche<br>BC Glossy white                                   |   |
| <b>Finitions</b><br><b>Finishes</b> ①+② |  |  |   |
| <b>Matériaux</b><br><b>Materials</b>    | Laiton massif ou/et Frêne Massif<br>Solid Brass or/and Ash wood                        | Verre triplex opale soufflé bouche<br>Opal triplex mouth-blown glass | Câble textile noir<br>Black textile cable |
| <b>Source</b><br><b>Lamping</b>         | Lampe de table-Table Lamp<br>G9 LED 5W max. non fournie<br>G9 LED 5W max. not included | Interrupteur sur câble<br>Cable Switch                               |   |
| <b>Designer</b>                         | José Lévy  |  |   |



Co Large BW/PG and Co Medium TW/PG

## Les Co

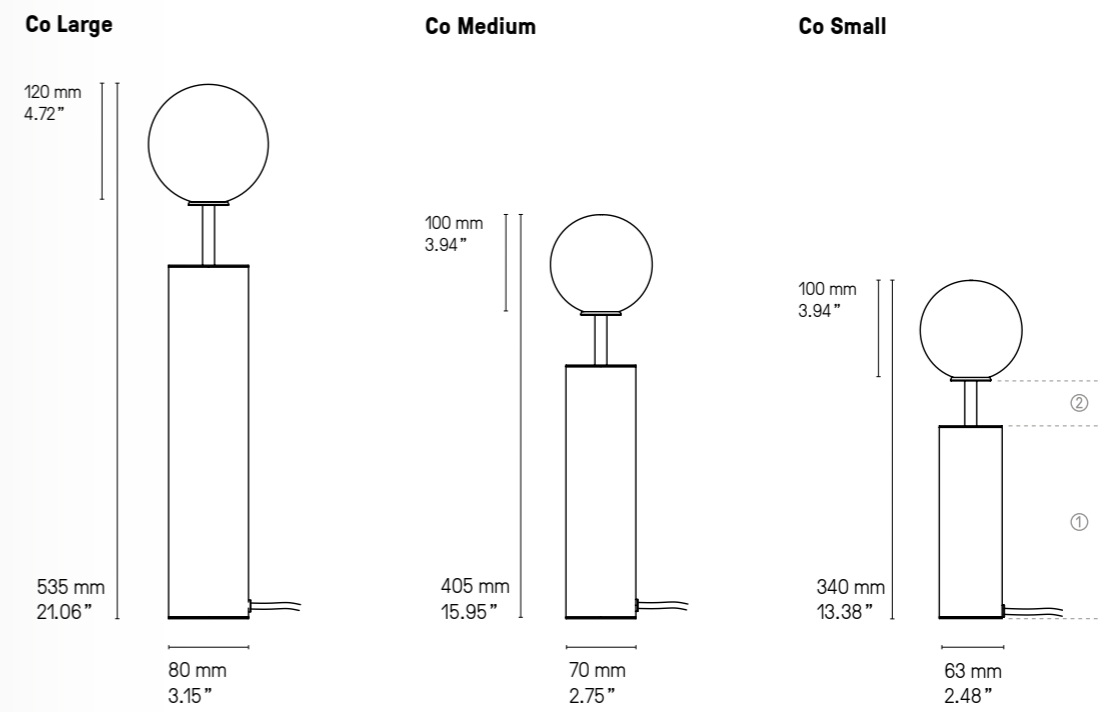

Co SB/PB, BW/PG and TW/PG



Co Medium BC & NO



## COMPASS

Avec la collection *Compass*, le marbre blanc et le noyer massif font leur entrée chez CVL. L'applique orientable avec son éclairage ciblé, trouve sa place aussi bien en liseuse qu'en luminaire architectural tandis que la suspension *Compass*, sculpture flottante, délivre une lumière agréable grâce à son verre opalin.



With the *Compass* collection, CVL innovates with new materials: white marble and solid walnut. The rotating wall light, with its orientable lighting, finds its place just as well as a reading light or as an architectural fixture, whereas the *Compass* pendant, a floating sculpture, provides subtle light thanks to its opaline glass.

**Finitions**  
**Finishes**

Détails page 285

|                                   |  |                                    |                                    |                       |
|-----------------------------------|--|------------------------------------|------------------------------------|-----------------------|
| ● Laiton satiné<br>SB Satin brass | ● Graphite satiné<br>SG Satin graphite | ● Nickel satiné<br>SN Satin nickel | ● Cuivre satiné<br>SC Satin copper | ● Bronze<br>BZ Bronze |
| ● Noyer<br>NO Walnut              | ● Marbre blanc<br>MA White marble      |                                    |                                    |                       |

**Matériaux**  
**Material**

|   |  |  |
|---|--|--|
| <b>Tous – All</b><br>Laiton massif<br>Solid Brass<br>Noyer massif ou Marbre Blanc<br>Solid Walnut or White marble | <b>Suspension – Pendant</b><br>Verrerie Opale soufflée bouche<br>Opal mouth-blown glass<br>Câble textile noir (longueur ≈ 2 m)<br>Black textile cable (length ≈ 78.7")<br><i>La longueur standard des câbles est de 2 mètres mais elle peut être diminuée à l'installation.<br/>The standard height of the cables is 2 meters (78.7") but can be adjusted to less during installation.</i> | <b>Applique – Wall light</b><br>Diffuseur en polycarbonate<br>Polycarbonate diffuser |
|---|--|--|

**Source**  
**Lamping**

Valeurs nominales  
Nominal power

|                               |         |        |     |                       |  |
|-------------------------------|---------|--------|-----|-----------------------|--|
| <b>Suspension – Pendant</b>   |         |        |     |                       |  |
| LED intégrée                  | 1060 lm | 2700°K | 17W | Variation (phase cut) |  |
| Integrated LED                | 1060 lm | 2700°K | 17W | Dimmable (phase cut)  |  |
| <b>Appliques – Wall light</b> |         |        |     |                       |  |
| LED intégrée                  | 331 lm  | 2700°K | 4W  | Variateur tactile     |  |
| Integrated LED                | 331 lm  | 2700°K | 4W  | Touch dimmer          |  |

**Designer**

Émilie Cathelineau



Compass Applique – Wall light SB/NO

**Compass Suspension – Pendant**

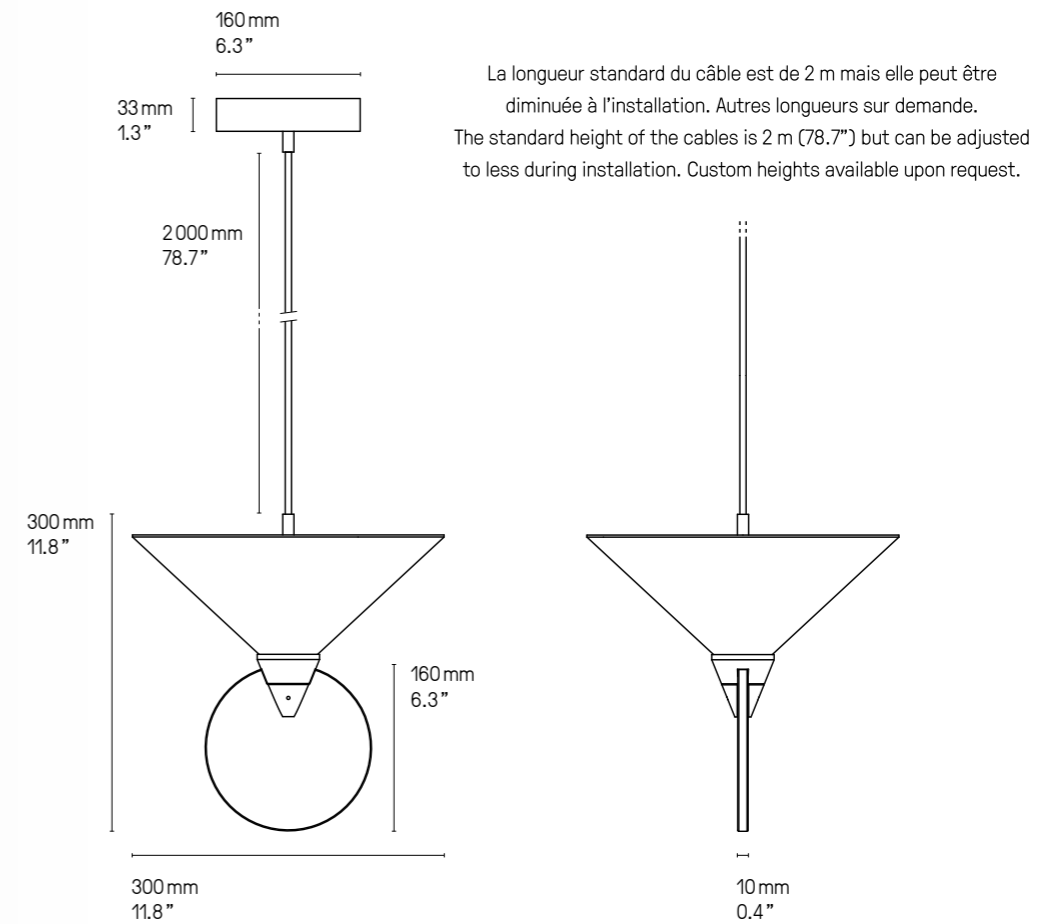

**Compass Applique – Wall light**

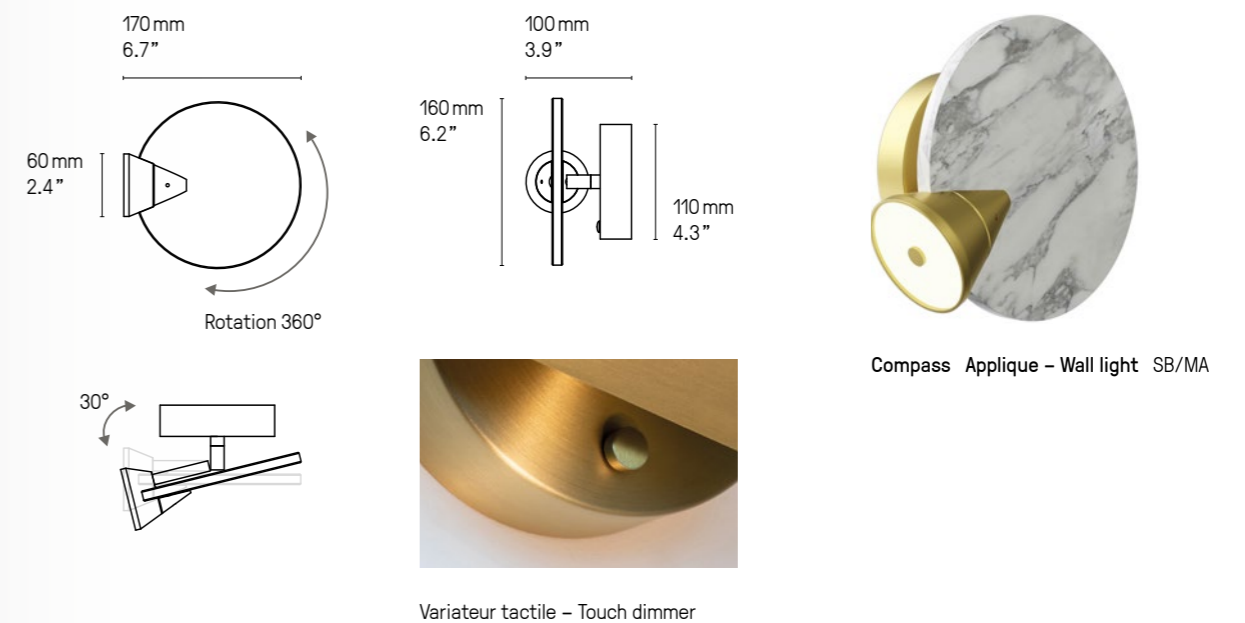

Compass Applique – Wall light SB/MA



## CONSTELLATION

Asymétrie et démultiplication, *Constellation* offre une infinité de possibilités à composer selon l'espace et vos inspirations. En mural ou au plafond, vos envies se dessinent en points lumineux.



Asymmetry and multiplying, *Constellation* offers an infinity of arrangement possibilities depending on the space and your inspirations. As a wall unit or a ceiling fixture, you can position the light any way you desire to.

**Finitions**  
**Finishes** ①

Détails page 285

|                                   |  |                                    |                       |
|-----------------------------------|--|------------------------------------|-----------------------|
| ● Laiton satiné<br>SB Satin brass | ● Graphite satiné<br>SG Satin graphite | ● Nickel satiné<br>SN Satin nickel | ● Bronze<br>BZ Bronze |
|-----------------------------------|--|------------------------------------|-----------------------|

**Finitions**  
**Finishes** ②

|                                   |  |                                    |                                    |                       |
|-----------------------------------|--|------------------------------------|------------------------------------|-----------------------|
| ● Laiton satiné<br>SB Satin brass | ● Graphite satiné<br>SG Satin graphite | ● Nickel satiné<br>SN Satin nickel | ● Cuivre satiné<br>SC Satin copper | ● Bronze<br>BZ Bronze |
|-----------------------------------|--|------------------------------------|------------------------------------|-----------------------|

**Matériaux**  
**Materials**

|                              |  |
|------------------------------|--|
| Laiton massif<br>Solid Brass | Verre triplex opale soufflé bouche<br>Opal triplex mouth-blown glass |
|------------------------------|--|

**Source**  
**Lamping**

Valeurs nominales  
Nominal values

|                                |                          |                  |          |   |   |
|--------------------------------|--------------------------|------------------|----------|---|---|
| LED intégrée<br>Integrated LED | 6 x 120 lm<br>6 x 120 lm | 3000°K<br>3000°K | 6W<br>6W | Alimentation intégrée fournie<br>Integrated power supply included       | Variation. Veuillez nous contacter<br>Dimming. Please, contact us |
|                                |                          |                  |          | ou - or<br>Alimentation séparée fournie<br>Remote power supply included |   |

|   |                |            |        |    |                                  |              |      |
|---|----------------|------------|--------|----|----------------------------------|--------------|------|
|  | Integrated LED | 6 x 120 lm | 3000°K | 6W | Integrated power supply included | Not dimmable | Damp |
|---|----------------|------------|--------|----|----------------------------------|--------------|------|

**Designer**

Émilie Cathelineau

**Alimentation intégrée**  
**Integrated power supply**

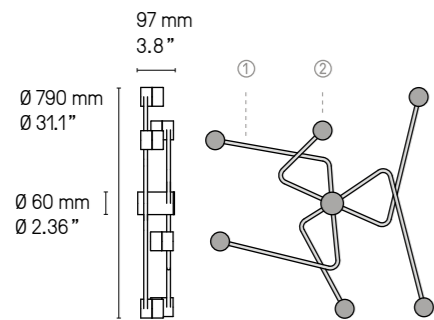

**Alimentation séparée**  
**Remote power supply**

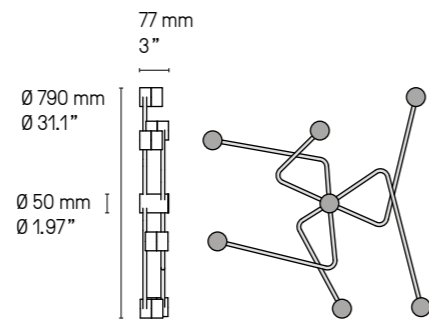

**UL Version**  
**fitted plate to cover outlet power box**

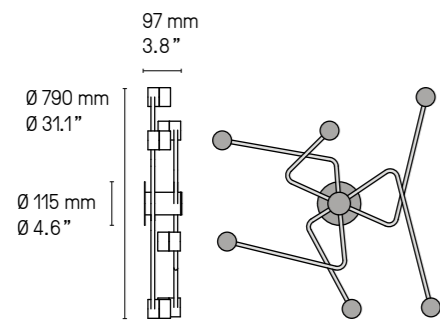

Constellation  
SG/SB



Constellation interconnectées SG/SG

**Exemples de compositions, avec 3, 5 et 8 modules**  
**Examples of arrangements, with 3, 5 or 8 units**

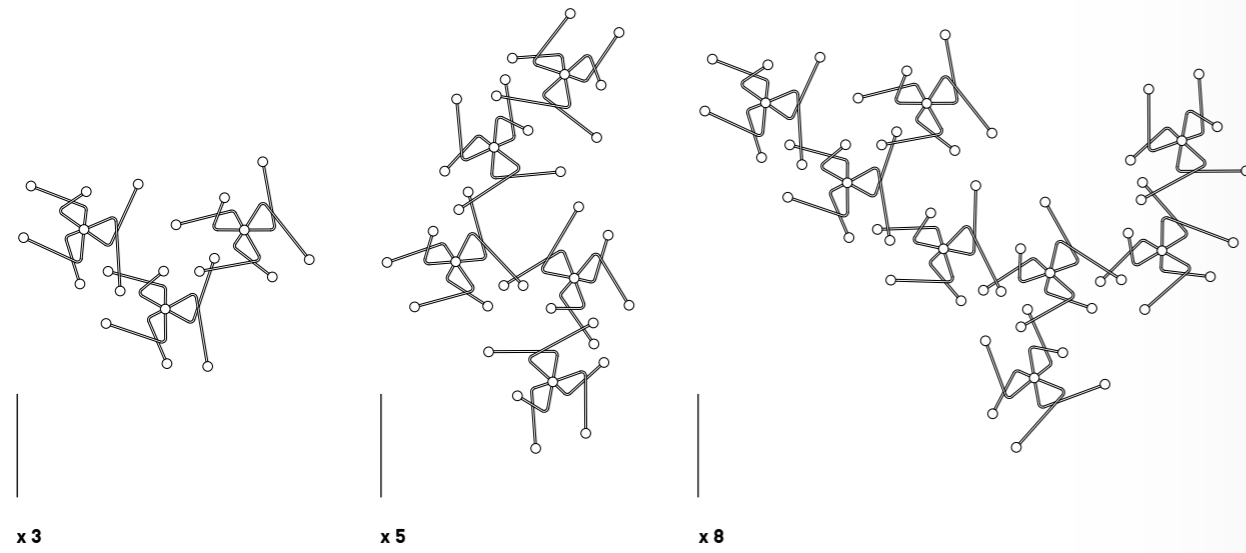

**Version interconnectée**  
**Interconnected version**

Ce système d'interconnection ne nécessite qu'une seule sortie électrique. Veuillez noter que cette version interconnectée n'est pas certifiée UL et que les points de connections ne sont pas lumineux. Merci de nous contacter pour connaître les compositions possibles.

The new interconnection system requires only one electrical outlet. Please be aware that this interconnected system is not UL certified and that the connection points have no light. Contact us for more information on possible arrangements.

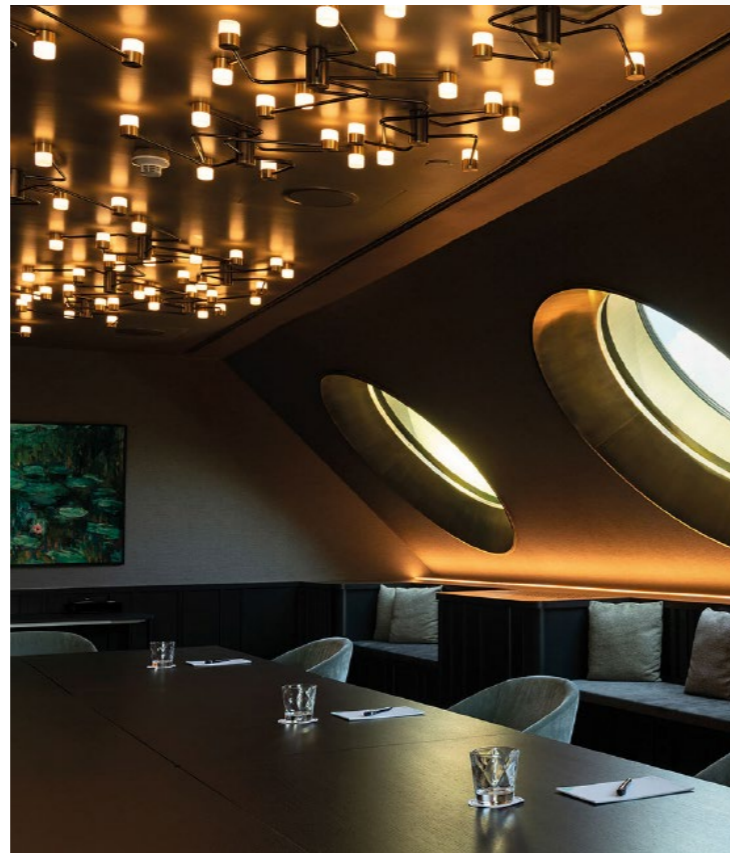
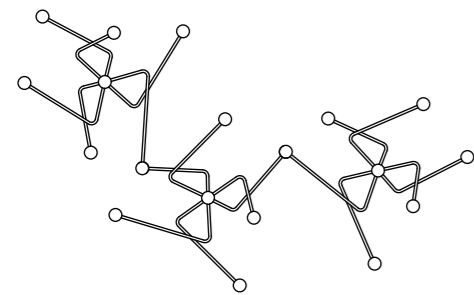

Constellations SG/SB indépendantes



Constellation SG/SB



## COUTURE







Discrète et raffinée, *Couture* est une petite lampe à poser dont l'abat-jour est tout simplement boutonné sur sa tige courbée en laiton. Sa silhouette toujours changeante, à l'élégance classique, en fait une pièce maîtresse pour un intérieur.



Discrete and refined, *Couture* is a small table lamp with a shade that is simply buttoned to its curved brass stem. Its ever-changing profile and classic elegance make it a stylish piece for interiors.

**Finitions  
Finishes**

Détails page 285

|   |   |   |   |  |
|---|---|---|---|--|
|  Laiton satiné |  Graphite satiné |  Nickel satiné |  Cuivre satiné |  Bronze |
| <b>SB</b> Satin brass   | <b>SG</b> Satin graphite  | <b>SN</b> Satin nickel  | <b>SC</b> Satin copper  | <b>BZ</b> Bronze   |
|  Laiton poli   |  Graphite poli   |  Nickel poli   |  Cuivre poli   |  |
| <b>PB</b> Polished brass  | <b>PG</b> Polished graphite   | <b>PN</b> Polished nickel   | <b>PC</b> Polished copper   |  |

**Abat-jour  
Lampshade**

|  |   |   |
|--|---|---|
| <input type="checkbox"/> Drop Paper® 100 | <input checked="" type="checkbox"/> Drop Paper® 101 | <input type="checkbox"/> Chinette blanche<br>White chinette |
|--|---|---|

**Matériaux  
Materials**

|                              |  |   |
|------------------------------|--|---|
| Laiton massif<br>Solid Brass | Abat-jour Drop Paper® M1<br>Lampshade Drop Paper® M1 | Câble textile noir (longueur ≈ 2 m)<br>Black textile cable (length ≈ 78.7") |
|------------------------------|--|---|

**Source  
Lamping**

|   |  |
|---|--|
| 1 x E14 LED 7W max. non fournie<br>1 x E14 LED 7W max. not included | Interrupteur sur câble<br>Cable switch |
|---|--|

**Designer**

Hervé Langlais

**Lampe de table – Table lamp**

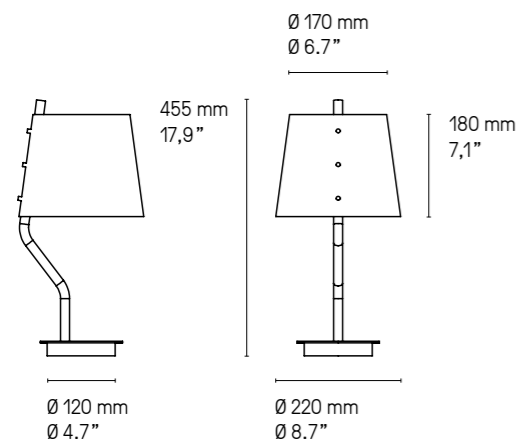

En standard, le dessous de la base sera toujours en finition graphite, si vous préférez une autre finition, merci de le préciser.

As standard, the underside of the base always comes in a satin graphite finish unless specified differently.



Lampe de table – Table lamp Couture SG



Lampe de table – Table lamp Couture SB



## EARTH

Un cœur lumineux, serti d'un métal ajouré de manière extrêmement fine ou d'un disque plein, confère à cette collection une touche Art déco. Du clair-obscur au moucharabieh, les idées de composition sont variées.



This wall light, with an illuminated center, assembled with an extremely fine openwork or a fully covered piece of metal gives this collection an Art déco style. From semi-darkness to a patterned light source, arrangements can vary.

**Finitions**  
**Finishes** ① + ②

|  |  |  |  |   |
|--|--|--|--|---|
| <span style="color: #c0c0c0;">●</span> Laiton satiné | <span style="color: #000000;">●</span> Graphite satiné | <span style="color: #cccccc;">●</span> Nickel satiné | <span style="color: #c08080;">●</span> Cuivre satiné | <span style="color: #808080;">●</span> Bronze |
| <b>SB</b> Satin brass                                | <b>SG</b> Satin graphite                               | <b>SN</b> Satin nickel                               | <b>SC</b> Satin copper                               | <b>BZ</b> Bronze                              |

Détails page 285

**Matériaux**  
**Materials**

|               |                            |
|---------------|----------------------------|
| Laiton massif | Diffuseur en polycarbonate |
| Solid brass   | Polycarbonate diffuser     |

**Source**  
**Lamping**

*Valeurs nominales*  
*Nominal values*

|                |         |        |     |                                 |                           |
|----------------|---------|--------|-----|---------------------------------|---------------------------|
| LED intégrée   | 1030 lm | 2700°K | 13W | Alim. électronique 24V intégrée | Variation (phase cut)     |
| Integrated LED | 1030 lm | 2700°K | 13W | Integrated 24V power supply     | Dimmable (phase cut)      |
| Integrated LED | 1030 lm | 2700°K | 15W | Integrated 24V power supply     | Dimmable (phase cut) Damp |

**Designer**

Émilie Cathelineau

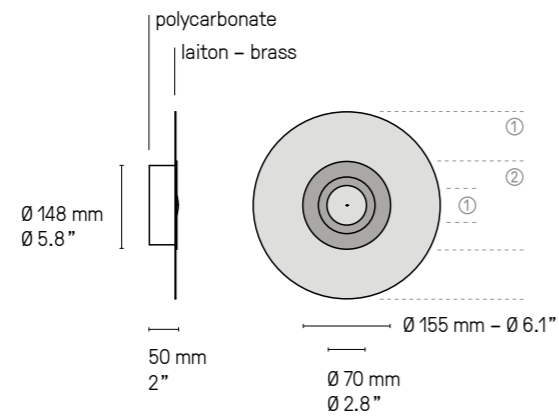

Partie centrale identique pour tous les modèles, quels que soient la taille et le motif.  
Identical central part for all *Earth* fixtures for any size and design.

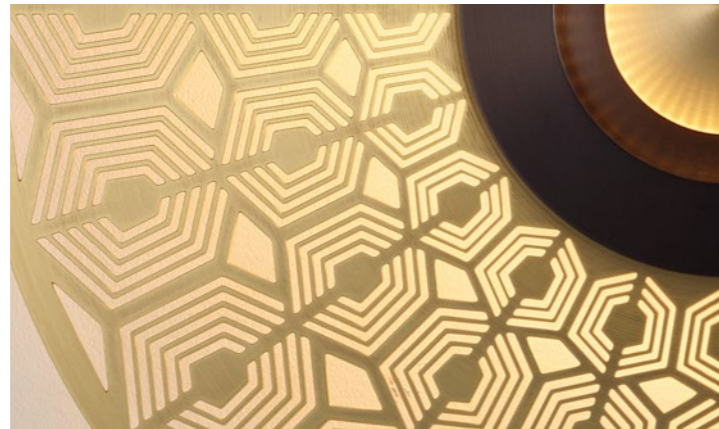

Earth Turtle 440 SB/SG

**Earth Sober** Ø 250 & Ø 330 mm

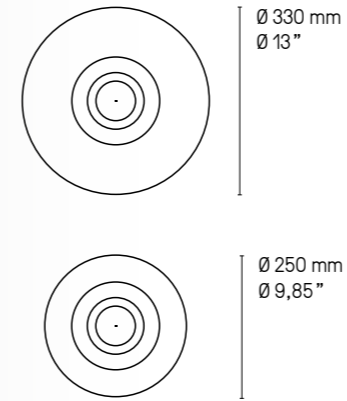

Earth Sober 330 SN/SG

**Earth Éclat** Ø 330 & Ø 440 mm

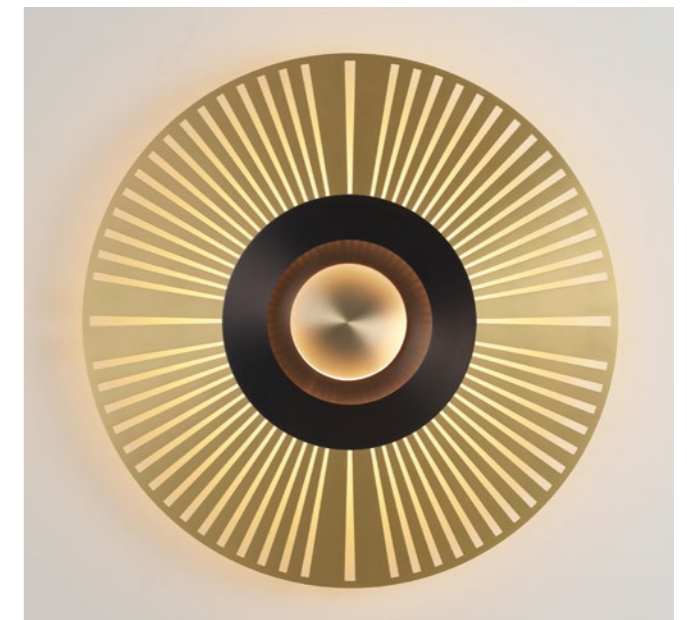
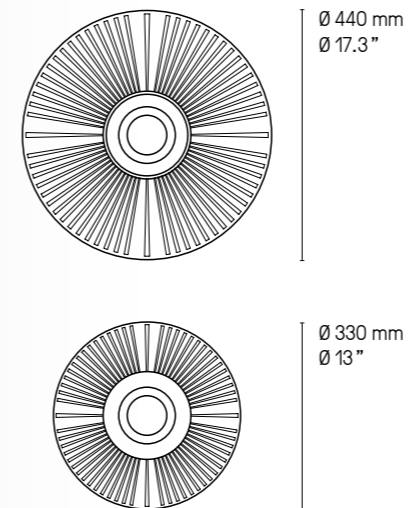

Earth Éclat 330 SB/SG

Earth Mandala Ø 330 & Ø 440 mm

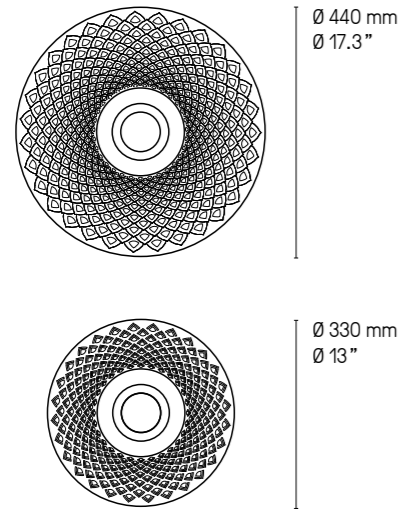

Earth Mandala 330 SB/SG

Earth Sun Ø 330 & Ø 440 mm

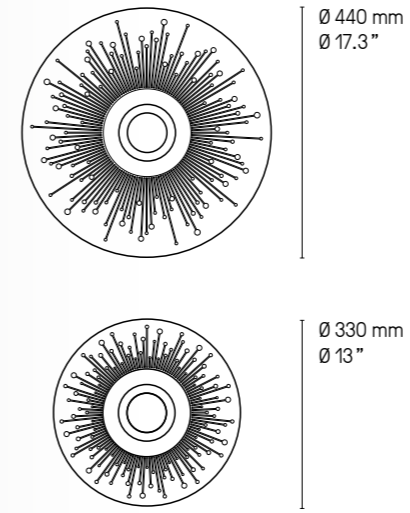

Earth Sun 330 SB/SG

Earth Palm Ø 330 & Ø 440 mm

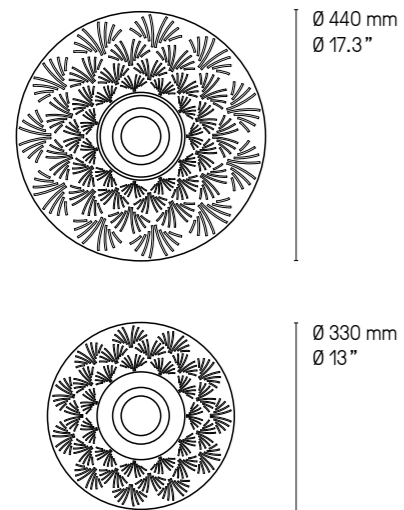

Earth Palm 330 SB/SG

Earth Turtle Ø 330 & Ø 440 mm

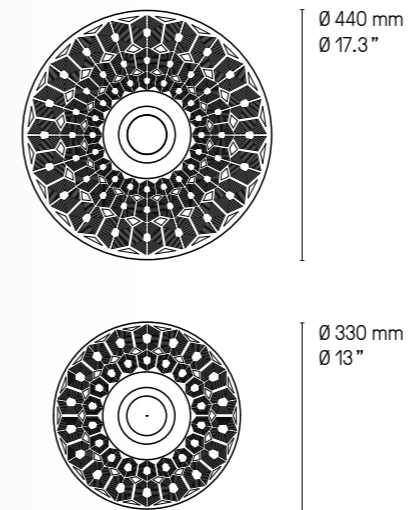

Earth Turtle 330 SG/SB

Earth Racine Ø 330 & Ø 440 mm

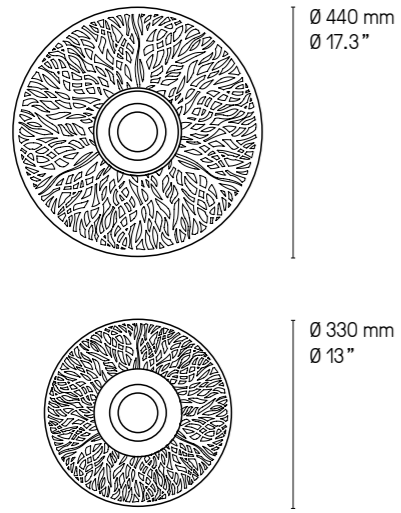

Earth Racine 330 SB/SG

Earth Radian Ø 350 mm

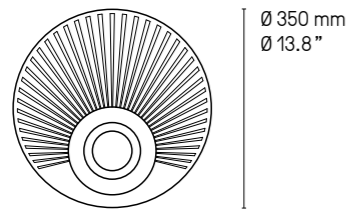

Earth Radian 350 SG/SB



Earth Radian 350 SB/SG



## ÉCLIPSE

Gamme d'appliques proposée en deux diamètres, *Éclipse* joue avec l'effet de disparition entre sa dalle de LED et ses deux disques en laiton. Un objet céleste qui ensoleille les architectures.



A range of wall light available in two diameters, *Éclipse* plays with the disappearing effect between its LED slab and its two brass discs. A celestial object to brighten up architecture..

**Finitions**  
**Finishes** ①+②

Détails page 285

|                 |                   |                 |                 |           |
|-----------------|-------------------|-----------------|-----------------|-----------|
| ● Laiton satiné | ● Graphite satiné | ● Nickel satiné | ● Cuivre satiné | ● Bronze  |
| SB Satin brass  | SG Satin graphite | SN Satin nickel | SC Satin copper | BZ Bronze |

En standard, le petit disque au centre du produit sera toujours en finition ① polie.  
Si vous préférez une finition satinée, merci de le préciser.  
The small centered disc on the front always comes in a polished finish ① but can be in satin if specified.

**Matériaux**  
**Materials** Laiton massif  
Solid Brass

**Description**  
**Features** L'applique *Éclipse* est fixe. Une fois positionnée au mur, elle ne peut pas tourner.  
Please be aware that discs are fixed and cannot be positioned in any other way.

**Source**  
**Lamping** LED intégrée 2500 lm 3 000°K 16W Alim. électronique intégrée Variation (phase cut)  
Integrated LED 2500 lm 3 000°K 16W Integrated power supply Dimmable (phase cut)

*Valeurs nominales*  
*Nominal values*

**Designer** Hervé Langlais

**Éclipse XL**

**Éclipse XS**

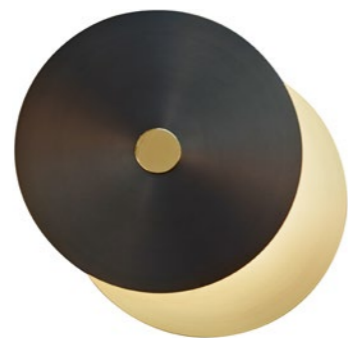
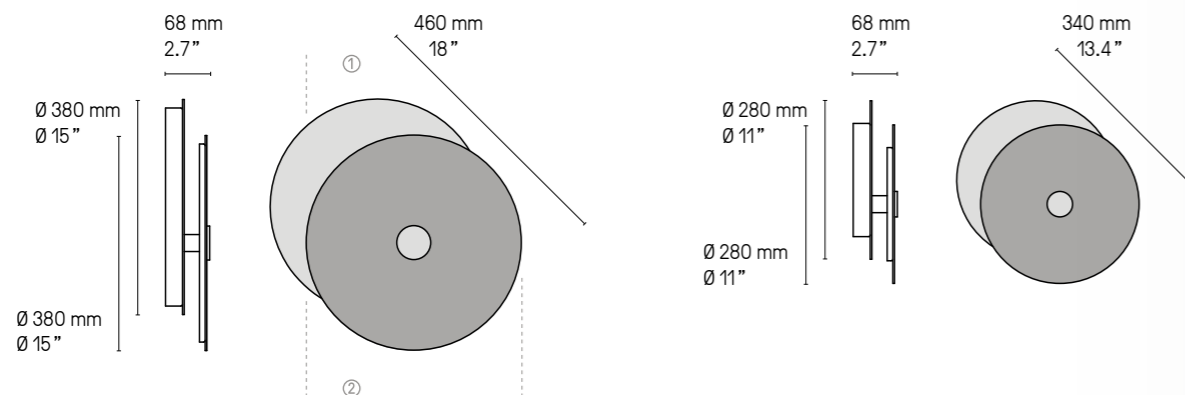

Éclipse XL SB/SG



Éclipse XS SN/SN XL SN/SG



## EXTRA

*Extra*, par Sylvain Willenz, est une série de luminaires faite de profilés carrés et ronds imbriqués les uns dans les autres de façon à créer, en toute simplicité, de nouvelles formes et typologies aux géométries essentielles.



*Extra*, by Sylvain Willenz, is a series of lightings made of square and round tubes, assembled together to create new shapes and arrangements with simple yet essential geometries.

**Finitions** ①+②  
**Finishes**

Détails page 285

- Laiton satiné
- Graphite satiné
- Nickel satiné
- Cuivre satiné
- Bronze
- SB** Satin brass
- SG** Satin graphite
- SN** Satin nickel
- SC** Satin copper
- BZ** Bronze

**Matériaux**  
**Materials**

Laiton massif  
Solid Brass

Câble textile (longueur ≈ 2 m)  
Textile cable (length ≈ 78.7")

*La longueur standard des câbles est de 2 mètres mais elle peut être diminuée à l'installation.  
The standard height of the cables is 2 meters (78.7") but can be adjusted to less during installation.*

**Source**  
**Lamping**

1 x GU10 PAR16 non fournie (ex.: 4 W = 450 lm)      Variable\*  
1 x GU10 PAR16 not included (ex.: 4 W = 450 lm)      Dimmable\*

This collection is not available for the USA.

**Designer**

Sylvain Willenz

\* Les luminaires variables nécessitent l'utilisation d'ampoules compatibles avec la variation.  
All dimmable light fixtures require the use of compatible bulbs.



Extra V1 SG/SB



Extra V2 SB/SG



Extra V3 SG/SB



Extra V4 SB/SG

**Extra Suspension – Pendant**

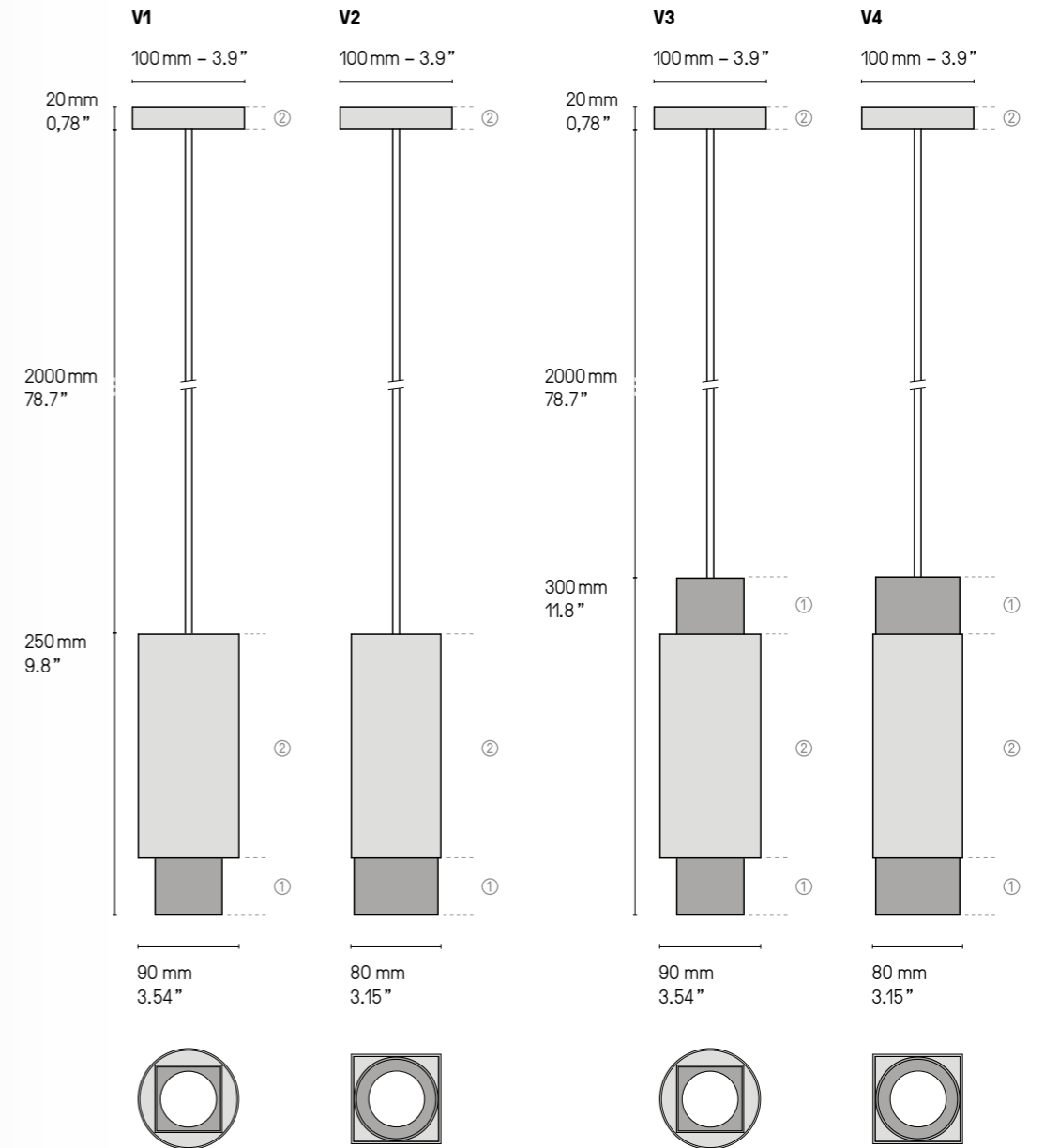

La longueur standard du câble est de 2 m mais elle peut être diminuée à l'installation. Autres longueurs sur demande.  
The standard height of the cables is 2 m (78.7") but can be adjusted to less during installation. Custom heights available upon request.



## FLÉA

*Fléa* est une petite applique suspendue en forme de trompette. À son extrémité, une verrerie facettée renvoie de subtils jeux de lumière sur le mur. Elle se décline également en suspension, seule ou à multiplier.



*Flea* is a small suspended trumpet-shaped wall light. Its faceted glassware subtly displays lighting effects onto the wall. It is also available as a pendant, alone or in combination.

|                  |                 |                   |                 |                 |           |
|------------------|-----------------|-------------------|-----------------|-----------------|-----------|
| <b>Finitions</b> | ● Laiton satiné | ● Graphite satiné | ● Nickel satiné | ● Cuivre satiné | ● Bronze  |
| <b>Finishes</b>  | SB Satin brass  | SG Satin graphite | SN Satin nickel | SC Satin copper | BZ Bronze |

Détails page 285

|              |               |                                     |  |
|--------------|---------------|-------------------------------------|--|
| <b>Câble</b> | ■ Tissu noir  | ■ Tissu or (sur demande uniquement) | <i>La longueur standard des câbles est de 2 m, pour les suspensions et 15 cm pour les appliques mais elle peut être diminuée à l'installation. Autres longueurs sur demande.<br/>The standard height of the cables is 2 m (78.7") for a pendant and 150 mm (5.9") for a wall light. It can be adjusted to less during installation. Custom heights available upon request.</i> |
| <b>Cable</b> | Black textile | Gold textile (on request only)      |  |

|                  |               |                          |               |
|------------------|---------------|--------------------------|---------------|
| <b>Matériaux</b> | Laiton massif | Verrerie soufflée bouche | Câble textile |
| <b>Materials</b> | Solid Brass   | Mouth-blown glass        | Textile cable |

|                |                             |            |
|----------------|-----------------------------|------------|
| <b>Source</b>  | G9 LED 5W max. non fournie  | Variation* |
| <b>Lamping</b> | G9 LED 5W max. not included | Dimming*   |

This collection is not available for the USA.

|                 |                    |
|-----------------|--------------------|
| <b>Designer</b> | Émilie Cathelineau |
|-----------------|--------------------|

\* Les luminaires variables nécessitent l'utilisation d'ampoules compatibles avec la variation.  
All dimmable light fixtures require the use of compatible bulbs.

### Applique – Wall light

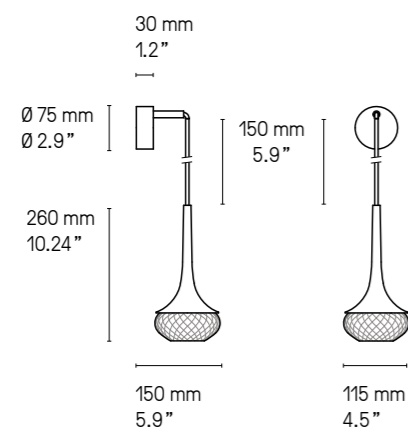

Applique – Wall light Fléa SB

La longueur standard des câbles est de 2 m pour les suspensions et 150 mm pour les appliques mais elle peut être diminuée à l'installation. Autres longueurs sur demande.  
The standard height of the cables is 2 m (78.7") for a pendant and 150 mm (5.9") for a wall light but can be adjusted to less during installation. Custom heights available upon request.

### Suspension – Pendant

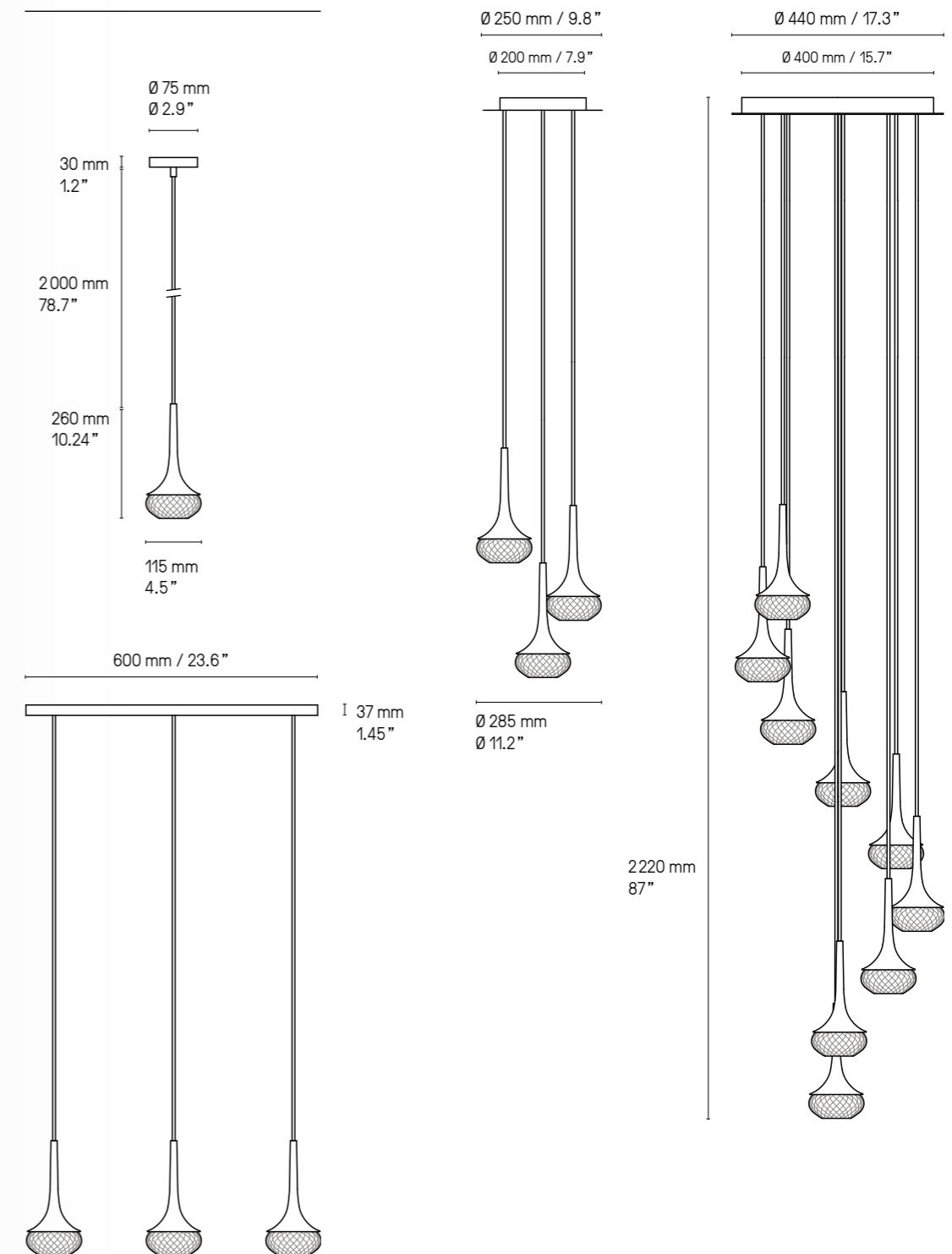

Il est possible de rassembler plusieurs suspensions sur un seul pavillon, circulaire ou rectangulaire. La version rectangulaire peut être adaptée à n'importe quelle longueur. La version circulaire a un diamètre maximum indiqué sur les croquis ci-dessus. Pour plus de renseignements, veuillez nous contacter.  
It is possible to cluster several pendants from one single canopy, either rectangular or circular. The rectangular canopy can be custom-made into any size to suit your requirements. As for the circular canopy, available sizes are illustrated above. Please contact us for further information.



## GAMMA

*Gamma* est un système graphique et versatile. C'est à partir de tubes métalliques et de cylindres blancs opalins, multipliés, que s'agence ainsi toute une gamme de luminaires.



*Gamma* is a striking and versatile lighting system. The design of this collection is based on the multiplication of metal tubes and opal white luminous cylinders, assembled like a chain.

**Finitions  
Finishes**

Détails page 287

|                                  |                                       |                                   |                                   |                     |
|----------------------------------|---------------------------------------|-----------------------------------|-----------------------------------|---------------------|
| Laiton satiné<br>SB Satin brass  | Graphite satiné<br>SG Satin graphite  | Nickel satiné<br>SN Satin nickel  | Cuivre satiné<br>SC Satin copper  | Bronze<br>BZ Bronze |
| Laiton poli<br>PB Polished brass | Graphite poli<br>PG Polished graphite | Nickel poli<br>PN Polished nickel | Cuivre poli<br>PC Polished copper |                     |

**Matériaux  
Materials**

|  |   |
|--|---|
| <b>Tous – All</b><br>Laiton massif<br>Solid Brass<br>Diffuseur polycarbonate blanc<br>White Polycarbonate diffuser | <b>Suspension – Pendant</b><br>Câble métallique et câble électrique transparent<br>Metal cable and transparent electric cable<br><i>La longueur standard des câbles est de 2 mètres mais elle peut être diminuée à l'installation.<br/>The standard height of the cables is 2 meters (78.7") but can be adjusted to less during installation.</i> |
|--|---|

**Source  
Lamping**

Valeurs nominales  
Nominal values

|                                     |         |        |     |                                       |                      |
|-------------------------------------|---------|--------|-----|---------------------------------------|----------------------|
| <b>Suspensions – Pendant lights</b> |         |        |     |                                       |                      |
| <b>Gamma L 19</b>                   |         |        |     |                                       |                      |
| LED intégrée                        | 1730 lm | 2700°K | 22W | Alim. 24V int. dans le pavillon       | Variable (phase cut) |
| Integrated LED                      | 1730 lm | 2700°K | 22W | Int. power supply 24V incl. in canopy | Dimmable (phase cut) |
| <b>Gamma R 40</b>                   |         |        |     |                                       |                      |
| LED intégrée                        | 3740 lm | 2700°K | 49W | Alim. 24V int. dans le pavillon       | Variable (phase cut) |
| Integrated LED                      | 3740 lm | 2700°K | 49W | Int. power supply 24V incl. in canopy | Dimmable (phase cut) |
| <b>Gamma R 58</b>                   |         |        |     |                                       |                      |
| LED intégrée                        | 5180 lm | 2700°K | 65W | Alim. 24V int. dans le pavillon       | Variable (phase cut) |
| Integrated LED                      | 5180 lm | 2700°K | 65W | Int. power supply 24V incl. in canopy | Dimmable (phase cut) |
| <b>Appliques – Wall lights</b>      |         |        |     |                                       |                      |
| <b>Gamma XS</b>                     |         |        |     |                                       |                      |
| LED intégrée                        | 480 lm  | 2700°K | 7W  | Alimentation 24V int. intégrée        | Variable (phase cut) |
| Integrated LED                      | 480 lm  | 2700°K | 7W  | Int. power supply 24V included        | Dimmable (phase cut) |
| <b>Gamma XL</b>                     |         |        |     |                                       |                      |
| LED intégrée                        | 1820 lm | 2700°K | 20W | Alimentation 24V int. intégrée        | Variable (phase cut) |
| Integrated LED                      | 1820 lm | 2700°K | 20W | Int. power supply 24V included        | Dimmable (phase cut) |

**Designer**

Sylvain Willenz

**Suspension – Pendant Gamma L 19**

13 x Tubes laiton – 6 x Tubes diffuseurs  
13 x Brass tubes – 6 x Diffuser tubes

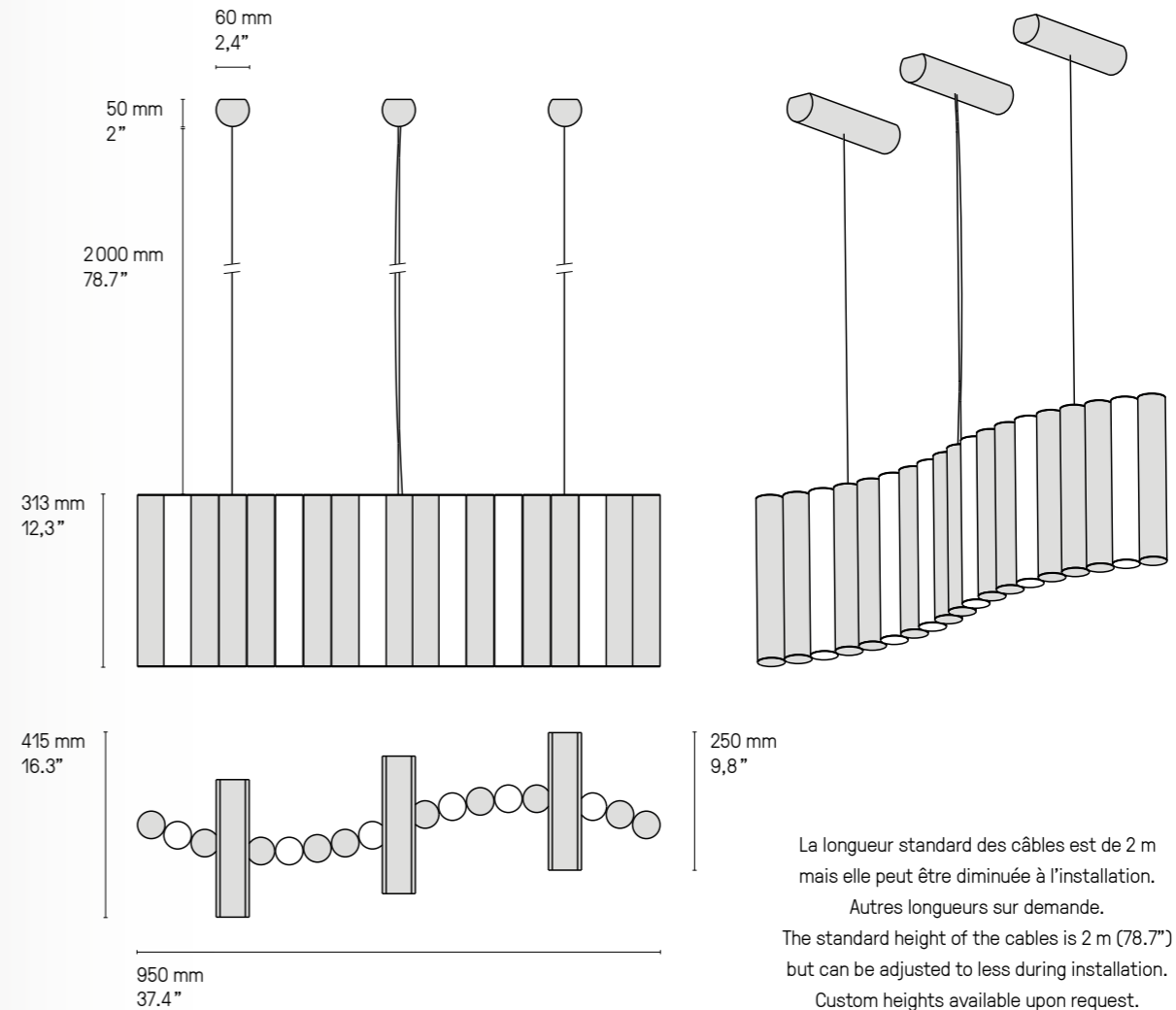

Gamma L 19 SB

**Suspension – Pendant Gamma R 40**

27 x Tubes laiton – 13 x Tubes diffuseurs  
 27 x Brass tubes – 13 x Diffuser tubes

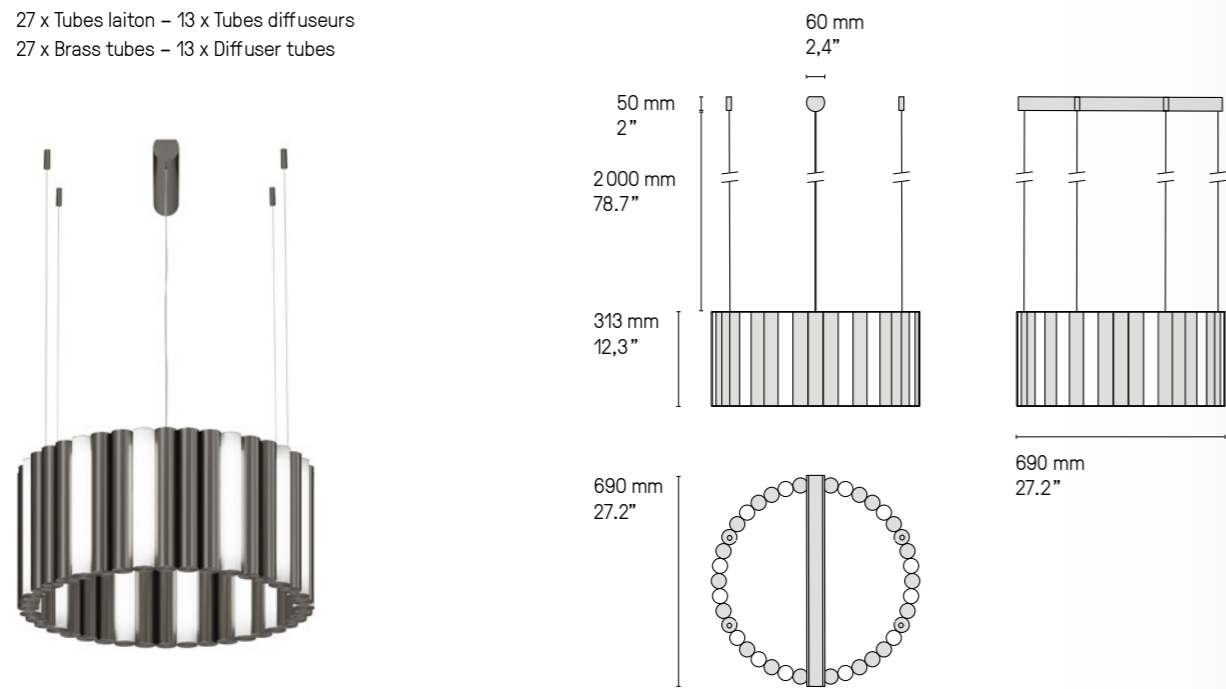

**Suspension – Pendant Gamma R 58**

40 x Tubes laiton – 18 x Tubes diffuseurs  
 40 x Brass tubes – 18 x Diffuser tubes

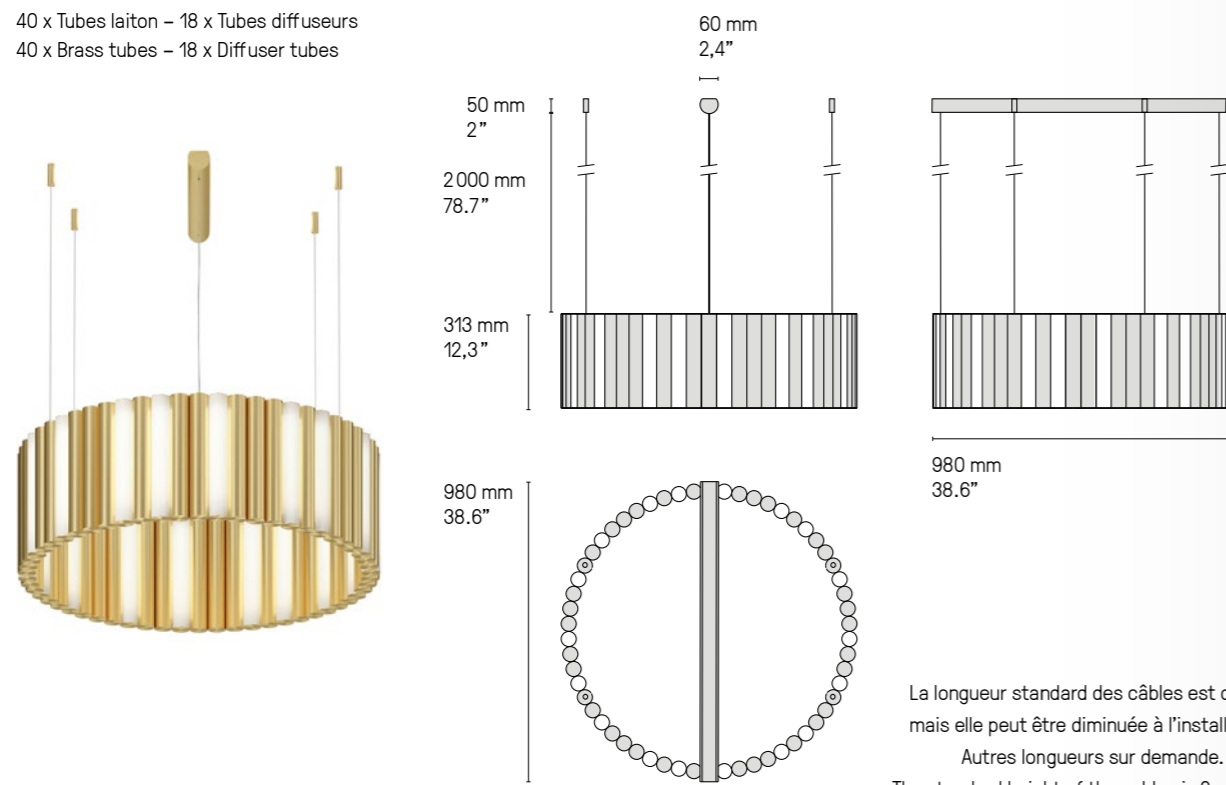

La longueur standard des câbles est de 2 m  
 mais elle peut être diminuée à l'installation.  
 Autres longueurs sur demande.  
 The standard height of the cables is 2 m (78.7")  
 but can be adjusted to less during installation.  
 Custom heights available upon request.



Gamma R 58 SG



Gamma XL SB

### Applique – Wall light Gamma XS

1 x Tube laiton – 2 x Tubes diffuseurs  
 1 x Brass tube – 2 x Diffuser tubes

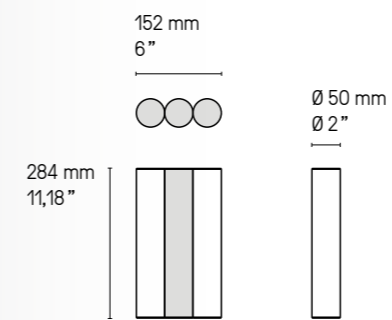

Gamma XS SB    Gamma XS SC    Gamma XS SN    Gamma XS SG

Retrouvez les variantes salle de bain (IP44) de ces modèles p.263  
 You will find the bathroom variants (IP44) of these designs p.263

### Applique – Wall light Gamma XL

2 x Tubes laiton – 2 x Tubes diffuseurs  
 2 x Brass tubes – 2 x Diffuser tubes

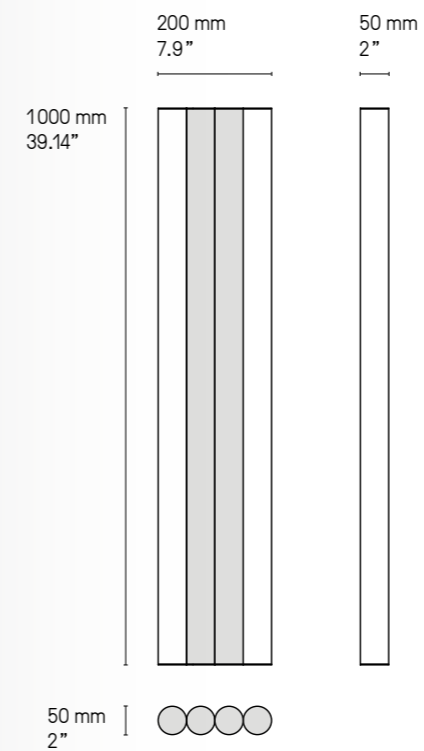

Gamma XL SG



## HAUSSMANN

Les appliques *Hausmann* s'inscrivent dans l'ancrage parisien de José Lévy et son héritage haussmannien. Dans un travail de « déconstruction » de ce style iconique, le designer a détourné le motif ornemental des moulures intérieures pour sculpter la base de ces appliques.



The *Hausmann* wall lights are part of José Lévy's Parisian roots and his Haussmannian heritage. In a process of 'deconstruction' of this iconic style, the designer has reinterpreted the ornamental motif of interior mouldings to sculpt the base of these wall lights.

**Finitions**  
**Finishes**

Détails page 285

- Laiton satiné  
SB Satin brass
- Graphite satiné  
SG Satin graphite
- Nickel satiné  
SN Satin nickel
- Cuivre satiné  
SC Satin copper
- Bronze  
BZ Bronze

**Matériaux**  
**Materials**

Tous – All  
Laiton massif  
Solid brass

**Source**  
**Lamping**

*Valeurs nominales*  
*Nominal values*

**Appliques – Wall lights**

**Hausmann Small**

|                |        |        |      |                                 |                      |
|----------------|--------|--------|------|---------------------------------|----------------------|
| LED intégrée   | 840 lm | 2700°K | 12 W | Alimentation 24 V intégrée      | Variable (phase cut) |
| Integrated LED | 840 lm | 2700°K | 12 W | Int. power supply 24 V included | Dimmable (phase cut) |

**Hausmann Large**

|                |         |        |      |                                 |                      |
|----------------|---------|--------|------|---------------------------------|----------------------|
| LED intégrée   | 1690 lm | 2700°K | 20 W | Alimentation 24 V intégrée      | Variable (phase cut) |
| Integrated LED | 1690 lm | 2700°K | 20 W | Int. power supply 24 V included | Dimmable (phase cut) |

**Designer**

José Lévy



Hausmann Large SB

**Hausmann**

**Hausmann Large**

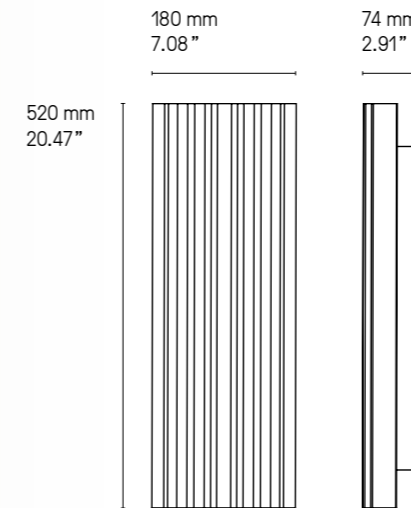

**Hausmann Small**

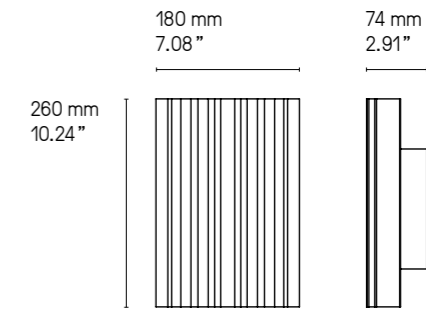

Hausmann Small SN



Hausmann Small SB



## JANED

Tel un petit phare de voiture ancienne, la coupelle de *Janed* vient refléter la lumière de la sphère opaline.



Like a small headlight from an old car, *Janed's* cup reflects the light of the opaline sphere

**Finitions Finishes** ① + ②

|                                   |  |                                    |                                    |                       |
|-----------------------------------|--|------------------------------------|------------------------------------|-----------------------|
| ● Laiton satiné<br>SB Satin brass | ● Graphite satiné<br>SG Satin graphite | ● Nickel satiné<br>SN Satin nickel | ● Cuivre satiné<br>SC Satin copper | ● Bronze<br>BZ Bronze |
|-----------------------------------|--|------------------------------------|------------------------------------|-----------------------|

Détails page 285

|                                    |   |                                     |                                     |
|------------------------------------|---|-------------------------------------|-------------------------------------|
| ● Laiton poli<br>PB Polished brass | ● Graphite poli<br>PG Polished graphite | ● Nickel poli<br>PN Polished nickel | ● Cuivre poli<br>PC Polished copper |
|------------------------------------|---|-------------------------------------|-------------------------------------|

|                            |  |   |   |
|----------------------------|--|---|---|
| <b>Matériaux Materials</b> | Tous – All<br>Laiton massif<br>Solid Brass | Tous – All<br>Verre triplex opale<br>Opal triplex glass | <b>Janed 140 Cable</b><br>Câble textile noir (longueur ≈ 2 m)<br>Black textile cable (length ≈ 79") |
|----------------------------|--|---|---|

**Source Lamping** Appliques – Wall mounted lights

**Janed 120 & 140 Simple**  
G9 LED 5W max. non fournie  
G9 LED 5W max. not included

Variable\*  
Dimmable\*

**Janed 140 Tirette/Cord**  
G9 LED 5W max. non fournie  
G9 LED 5W max. not included

Interrupteur par tirette  
Pull cord switch

**Janed 140 Cable**  
G9 LED 5W max. non fournie  
G9 LED 5W max. not included

Interrupteur sur le câble  
Cable switch

**Lampe de table – Table lamp**

**Lampe de table – Table lamp**  
G9 LED 5W max. non fournie  
G9 LED 5W max. not included

Interrupteur sur le câble  
Cable switch

**Designer** Émilie Cathelineau

\* Les luminaires variables nécessitent l'utilisation d'ampoules compatibles avec la variation.  
All dimmable light fixtures require the use of compatible bulbs.

**US Version fitted plate to cover outlet power box**

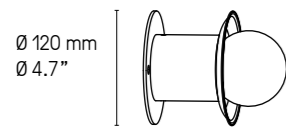

Applique – Wall mounted light  
Janed 140 Simple SB



Applique – Wall mounted light  
Janed 140 Simple SB/SG

Retrouvez les variantes salle de bain (IP44) de ces modèles p.265  
You will find the bathroom variants (IP44) of these designs p.265

**Janed Appliques – Wall lights**

**Janed 120 Simple**

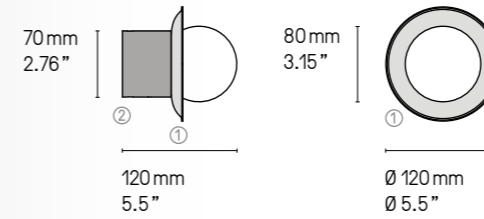

**Janed 140 Simple**

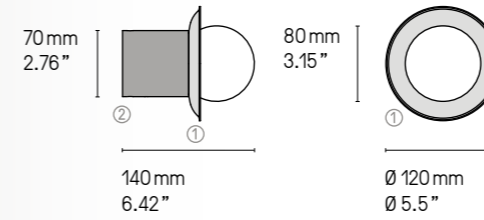

**Janed 140 Tirette/Cord**

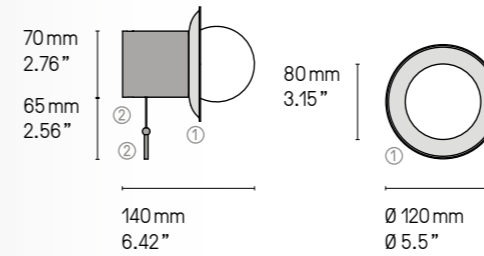

**Janed 140 Cable**

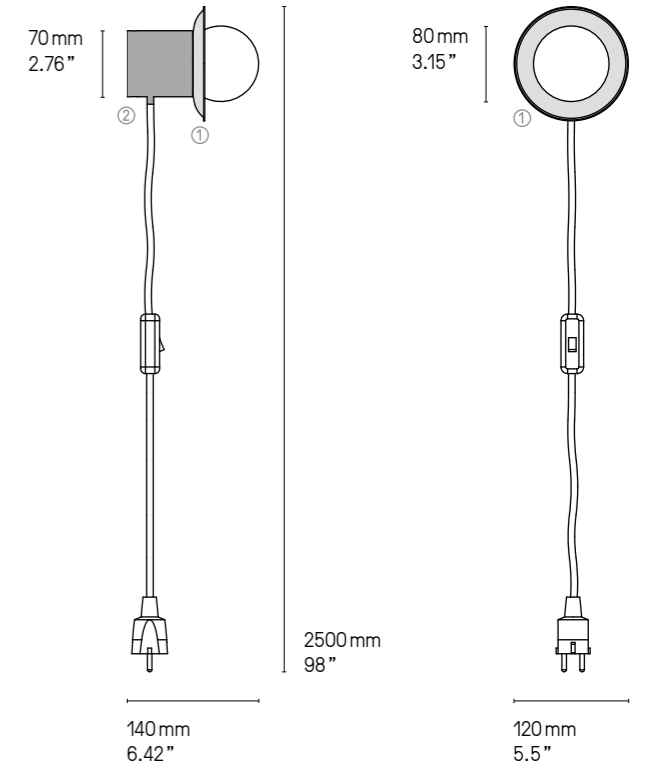

La longueur des câbles est réglable à l'installation.  
The height of the cables can be adjusted during installation.

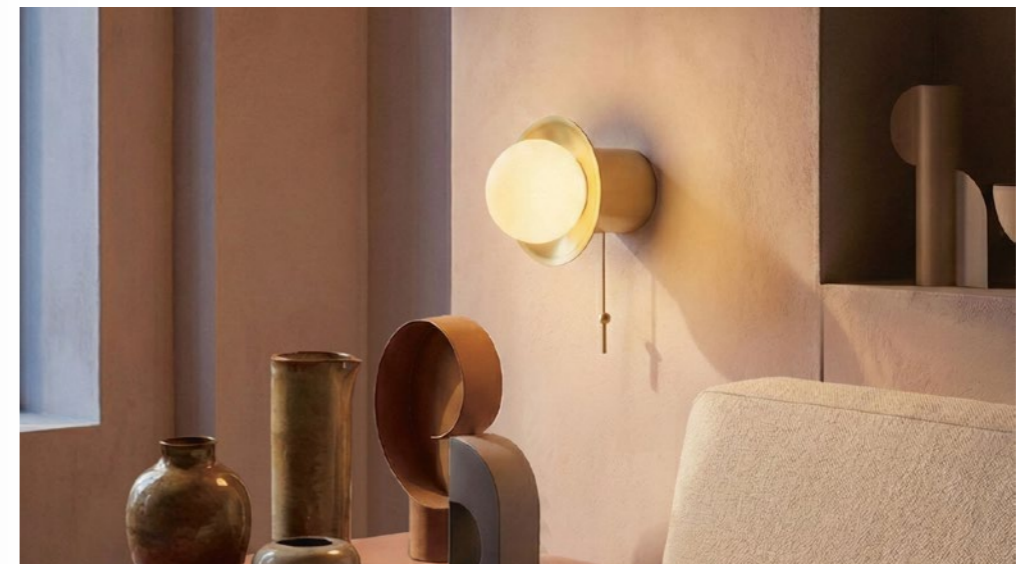

Applique – Wall mounted light Janed 140 Tirette/Cord SB



Applique – Wall mounted light  
Janed 140 Simple SN

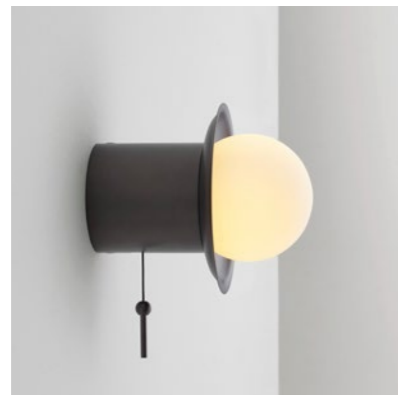

Applique – Wall mounted light  
Janed 140 Tirette – Cord SG



Applique – Wall mounted light  
Janed 140 Cable PN

Longueur de câble sur mesure possible.  
Custom cable dimensions upon request.



Appliques – Wall mounted lights Janed 120 Simple SB/SG



Lampe de table – Table lamp Janed SB

**Janed Lampe de table – Table lamp**

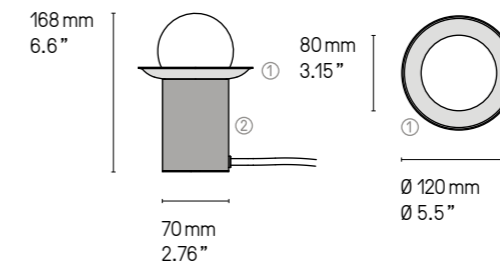

Lampe de table – Table lamp Janed SG



## LINK









Sobre et minimaliste, la collection *Link* encadre la lumière. Selon l'orientation du luminaire, la ligne épurée s'inscrit dans l'espace vertical et horizontal.



Simple and minimalist, the *Link* collection frames the light. Depending on the position of the light, the refined line can be fitted vertically or horizontally.

## Finitions Finishes

Détails page 285

|  |   |   |  |   |
|--|---|---|--|---|
|  Laiton satiné<br>SB Satin brass  |  Graphite satiné<br>SG Satin graphite  |  Nickel satiné<br>SN Satin nickel  |  Cuivre satiné<br>SC Satin copper  |  Bronze<br>BZ Bronze |
|  Laiton poli<br>PB Polished brass |  Graphite poli<br>PG Polished graphite |  Nickel poli<br>PN Polished nickel |  Cuivre poli<br>PC Polished copper |   |

## Matériaux Materials

|                              |  |   |
|------------------------------|--|---|
| Laiton massif<br>Solid Brass | Diffuseur polycarbonate satiné<br>Satin Polycarbonate diffuser | <b>Lampadaire – Floor Lamp</b><br>Câble textile noir (longueur ≈ 2 m)<br>Black textile cable (length ≈ 78.7") |
|------------------------------|--|---|

## Source Lamping

Valeurs nominales  
Nominal values

### Appliques – Wall lights

#### Link 985 (985 mm – 38.8")

|  |        |        |     |                             |                      |      |
|--|--------|--------|-----|-----------------------------|----------------------|------|
| LED intégrée   | 860 lm | 2700°K | 10W | Alim. électronique 24V int. | Variable (phase cut) |      |
| Integrated LED   | 860 lm | 2700°K | 10W | Int. power supply 24V incl. | Dimmable (phase cut) |      |
|  Integrated LED | 860 lm | 2700°K | 10W | Int. power supply 24V incl. | Not dimmable         | Damp |

#### Link 725 (725 mm – 28.5")

|  |        |        |    |                             |                      |      |
|--|--------|--------|----|-----------------------------|----------------------|------|
| LED intégrée   | 620 lm | 2700°K | 8W | Alim. électronique 24V int. | Variable (phase cut) |      |
| Integrated LED   | 620 lm | 2700°K | 8W | Int. power supply 24V incl. | Dimmable (phase cut) |      |
|  Integrated LED | 620 lm | 2700°K | 8W | Int. power supply 24V incl. | Not dimmable         | Damp |

#### Link 525 (525 mm – 20.7")

|  |        |        |    |                             |                      |      |
|--|--------|--------|----|-----------------------------|----------------------|------|
| LED intégrée   | 430 lm | 2700°K | 6W | Alim. électronique 24V int. | Variable (phase cut) |      |
| Integrated LED   | 430 lm | 2700°K | 6W | Int. power supply 24V incl. | Dimmable (phase cut) |      |
|  Integrated LED | 430 lm | 2700°K | 6W | Int. power supply 24V incl. | Not dimmable         | Damp |

#### Link 375 (375 mm – 14.8")

|  |        |        |    |                             |                      |      |
|--|--------|--------|----|-----------------------------|----------------------|------|
| LED intégrée   | 290 lm | 2700°K | 5W | Alim. électronique 24V int. | Variable (phase cut) |      |
| Integrated LED   | 290 lm | 2700°K | 5W | Int. power supply 24V incl. | Dimmable (phase cut) |      |
|  Integrated LED | 290 lm | 2700°K | 5W | Int. power supply 24V incl. | Not dimmable         | Damp |

#### Link 275 (275 mm – 10.8")

|  |        |        |    |                             |                      |      |
|--|--------|--------|----|-----------------------------|----------------------|------|
| LED intégrée   | 290 lm | 2700°K | 4W | Alim. électronique 24V int. | Variable (phase cut) |      |
| Integrated LED   | 290 lm | 2700°K | 4W | Int. power supply 24V incl. | Dimmable (phase cut) |      |
|  Integrated LED | 290 lm | 2700°K | 4W | Int. power supply 24V incl. | Not dimmable         | Damp |

### Liseuses murales – Reading wall lights

#### Link 320 (320 mm – 12.7")

|  |        |        |    |                             |                      |      |
|--|--------|--------|----|-----------------------------|----------------------|------|
| LED intégrée   | 160 lm | 2700°K | 2W | Alimentation 24V int.       | Non variable         |      |
| Integrated LED   | 160 lm | 2700°K | 2W | Int. power supply 24V incl. | Non dimmable         |      |
|  Integrated LED | 100 lm | 2700°K | 2W | Int. power supply 24V incl. | Dimmable (phase cut) | Damp |

#### Link 410 (410 mm – 16.1")

|  |        |        |    |                             |                      |                                |
|--|--------|--------|----|-----------------------------|----------------------|--------------------------------|
| LED intégrée   | 250 lm | 2700°K | 4W | Alimentation 24V int.       | Variable (phase cut) | Interrupteur intégré en option |
| Integrated LED   | 250 lm | 2700°K | 4W | Int. power supply 24V incl. | Dimmable (phase cut) | Integrated switch: optional    |
|  Integrated LED | 150 lm | 2700°K | 4W | Int. power supply 24V incl. | Dimmable (phase cut) | Damp                           |

#### Link 580 (580 mm – 22.8")

|  |        |        |    |                             |                      |                                |
|--|--------|--------|----|-----------------------------|----------------------|--------------------------------|
| LED intégrée   | 500 lm | 2700°K | 7W | Alimentation 24V int.       | Variable (phase cut) | Interrupteur intégré en option |
| Integrated LED   | 500 lm | 2700°K | 7W | Int. power supply 24V incl. | Dimmable (phase cut) | Integrated switch: optional    |
|  Integrated LED | 290 lm | 2700°K | 7W | Int. power supply 24V incl. | Dimmable (phase cut) | Damp                           |

#### Link double 610 (610 mm – 24.1")

|  |        |        |    |                             |                      |      |
|--|--------|--------|----|-----------------------------|----------------------|------|
| LED intégrée   | 500 lm | 2700°K | 7W | Alimentation 24V int.       | Variable (phase cut) |      |
| Integrated LED   | 500 lm | 2700°K | 7W | Int. power supply 24V incl. | Dimmable (phase cut) |      |
|  Integrated LED | 290 lm | 2700°K | 7W | Int. power supply 24V incl. | Dimmable (phase cut) | Damp |

#### Link double 960 (960 mm – 37.8")

|  |         |        |     |                             |                      |      |
|--|---------|--------|-----|-----------------------------|----------------------|------|
| LED intégrée   | 1010 lm | 2700°K | 12W | Alimentation 24V int.       | Variable (phase cut) |      |
| Integrated LED   | 1010 lm | 2700°K | 12W | Int. power supply 24V incl. | Dimmable (phase cut) |      |
|  Integrated LED | 580 lm  | 2700°K | 12W | Int. power supply 24V incl. | Dimmable (phase cut) | Damp |

#### Link double 1300 (1300 mm – 51.2")

|  |         |        |     |                             |                      |                                |
|--|---------|--------|-----|-----------------------------|----------------------|--------------------------------|
| LED intégrée   | 1350 lm | 2700°K | 17W | Alimentation 24V int.       | Variable (phase cut) | 2 interrupteurs int. en option |
| Integrated LED   | 1350 lm | 2700°K | 17W | Int. power supply 24V incl. | Dimmable (phase cut) | 2 int. switches: optional      |
|  Integrated LED | 770 lm  | 2700°K | 17W | Int. power supply 24V incl. | Dimmable (phase cut) | Damp                           |

## Source Lamping

Valeurs nominales  
Nominal values

### Lampadaire – Floor lamp

|                |         |        |     |                             |                      |
|----------------|---------|--------|-----|-----------------------------|----------------------|
| LED intégrée   | 1690 lm | 2700°K | 21W | Alimentation 24V int.       | Variateur à pied     |
| Integrated LED | 1690 lm | 2700°K | 21W | Int. power supply 24V incl. | Foot operated dimmer |

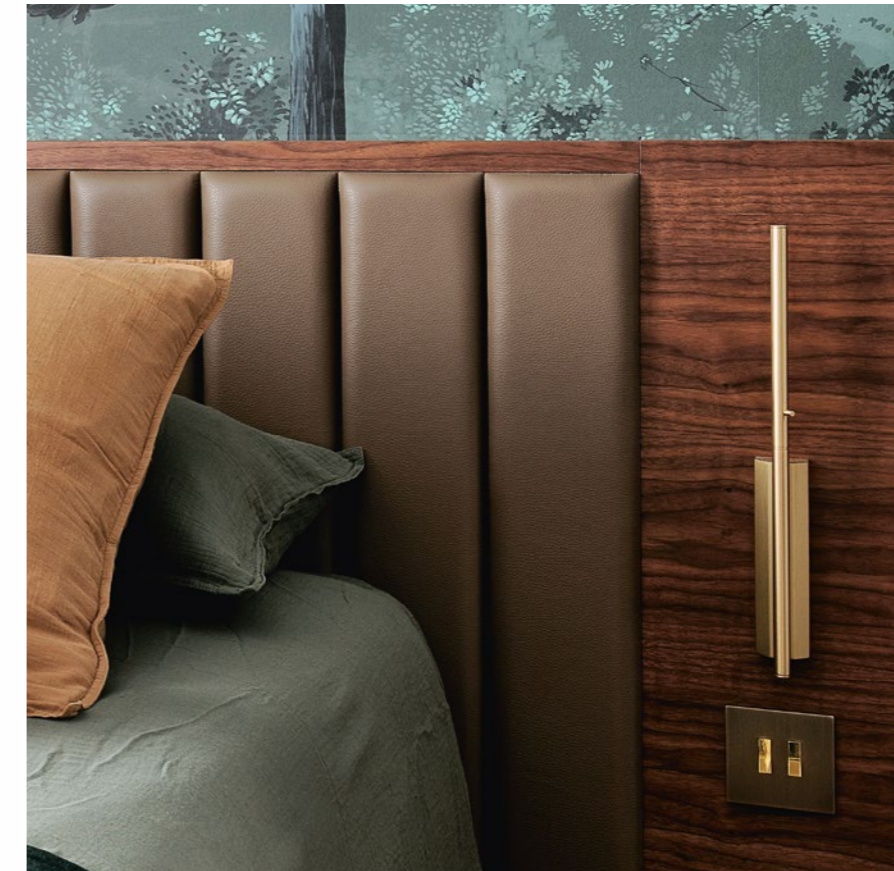

Liseuse murale – Reading wall light Link 410 SB



Appliques – Wall lights

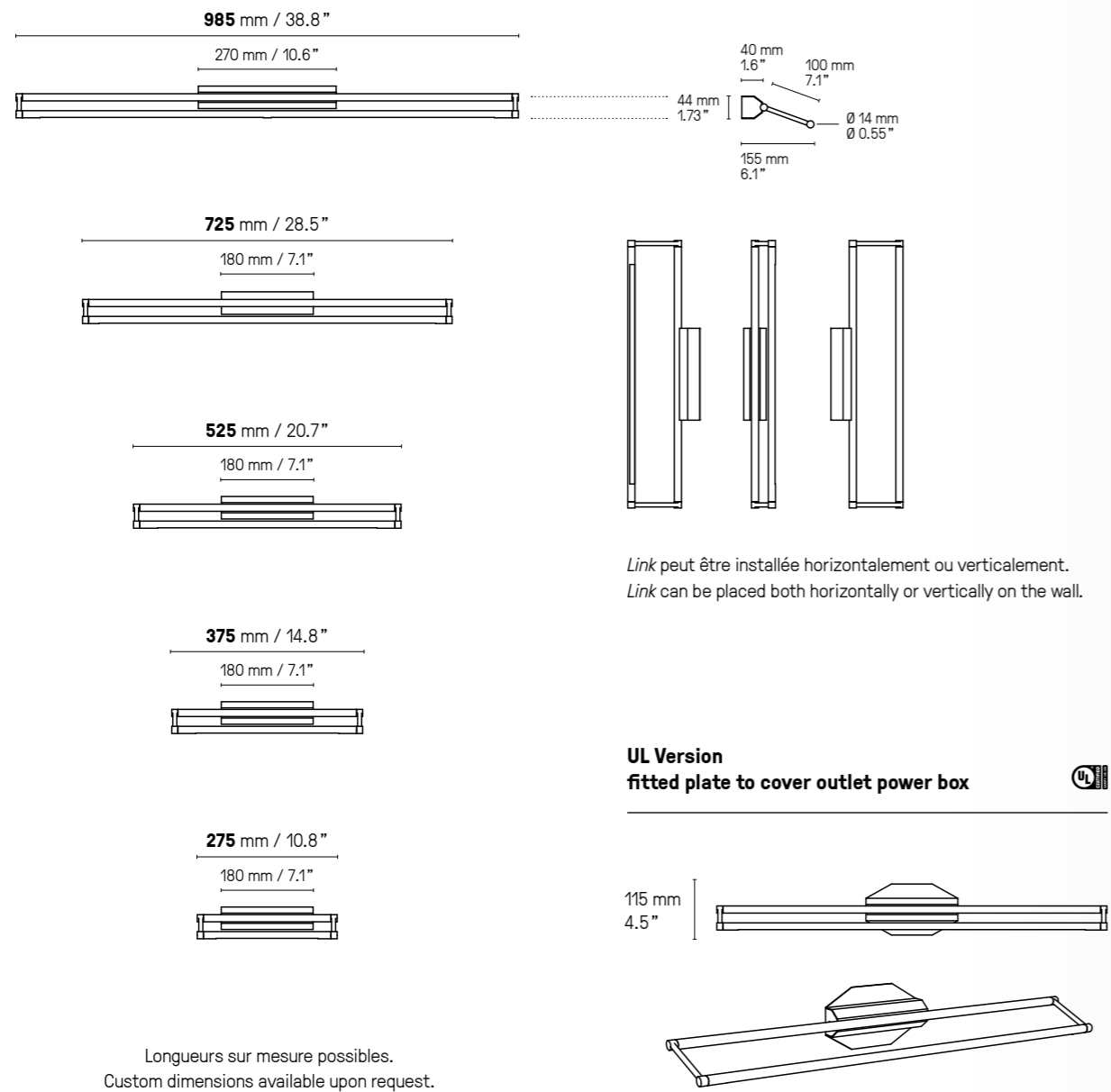

Description  
Features

Cette applique est réglable sur 2 axes. Le tube avant, dans lequel se trouve la LED tourne afin de diriger la lumière dans n'importe quelle direction. L'ensemble formant un cadre peut également pivoter de haut en bas si l'applique est installée à l'horizontale, ou de gauche à droite si elle est installée à la verticale.

The wall light is adjustable in 2 ways. The front LED bar can be spinned around to diffuse the light in any direction and the rectangular frame can be flipped up and down when the light is positioned horizontally, and side to side when positioned vertically.

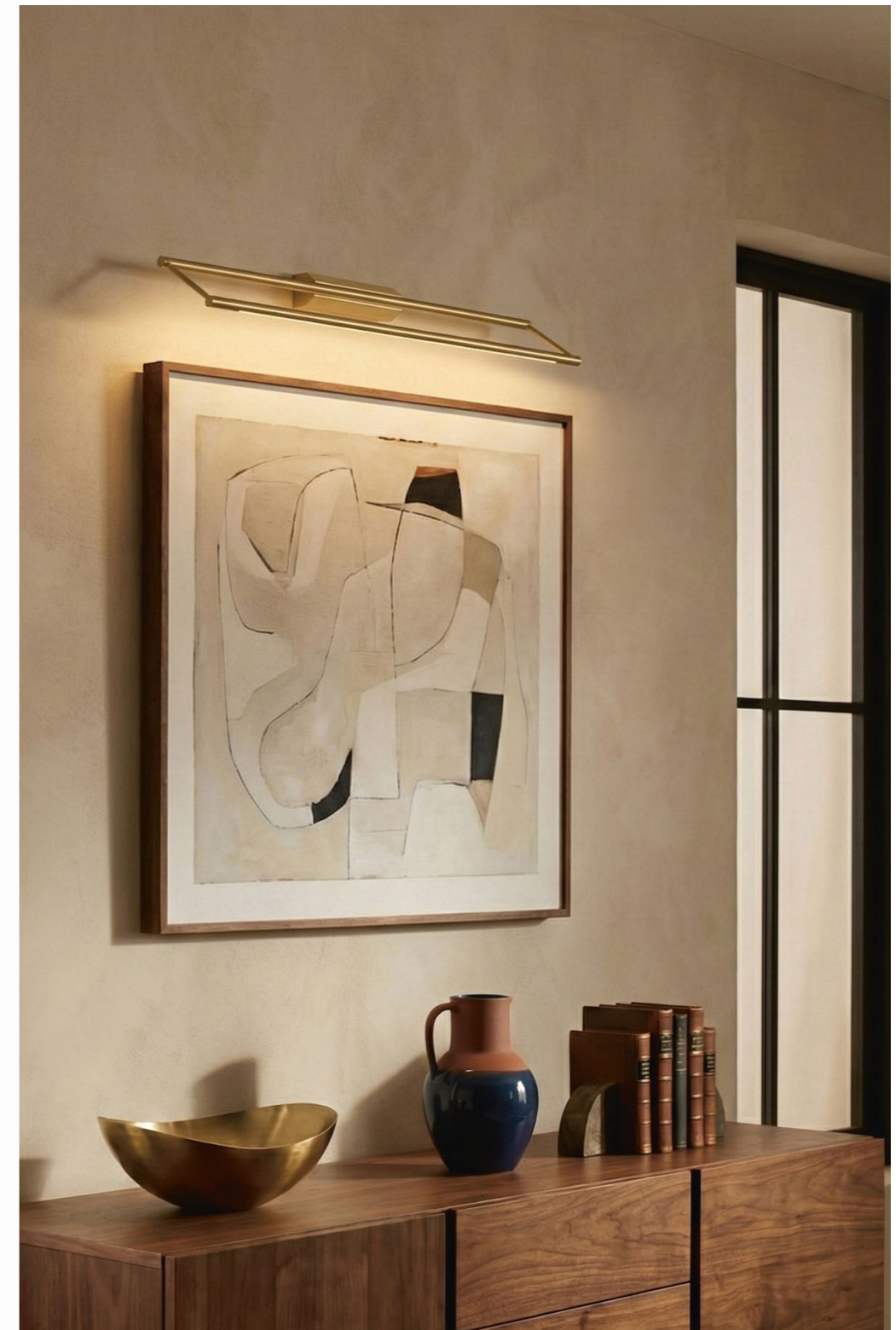

Applique – Wall light Link 985 SB

Liseuses murales – Reading wall lights

Longueurs sur mesure possibles  
 Retrouvez les variantes salle de bain (IP44) de ces modèles p.267  
 Custom dimensions available upon request  
 You will find the bathroom variants (IP44) of these designs p.267

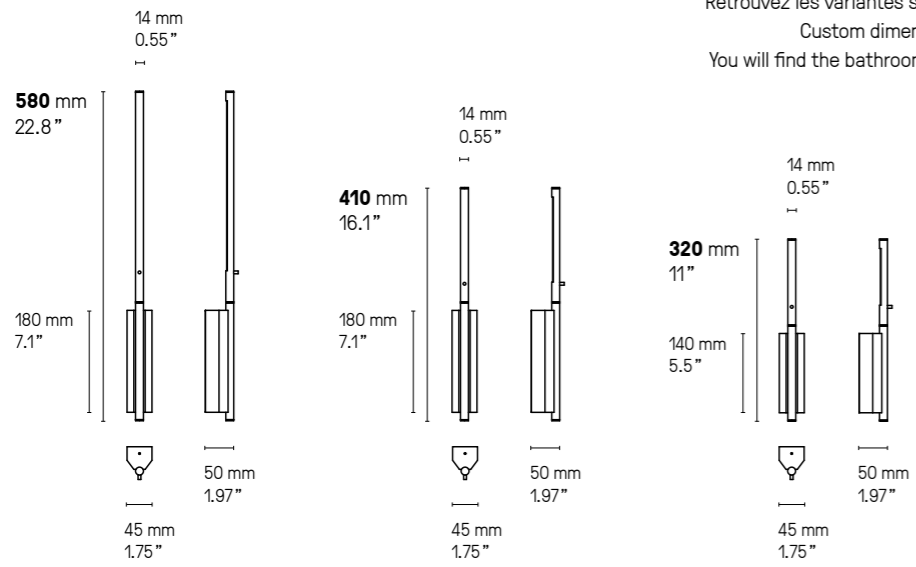

Interrupteur en option  
 Switch in option

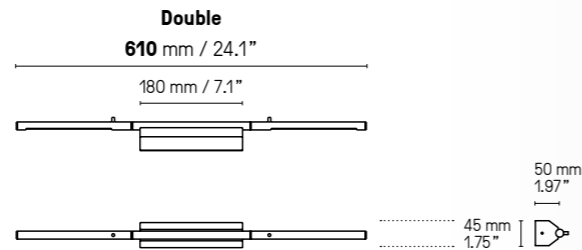
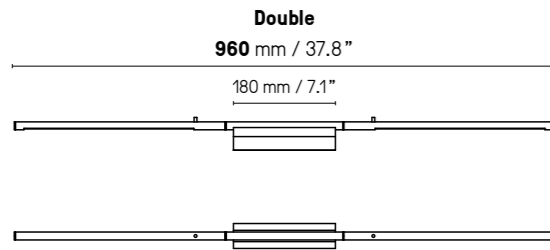
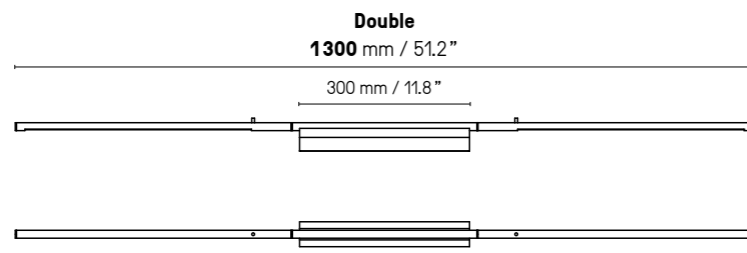

Retrouvez les variantes salle de bain (IP44) de ces modèles p.220  
 You will find the bathroom variants (IP44) of these designs p.220



Le tube avant, dans lequel se trouve la LED, tourne afin de diriger la lumière dans n'importe quelle direction.  
 The front LED bar can be spun around to diffuse the light in any direction.



**UL Version  
 fitted plate  
 to cover outlet  
 power box**

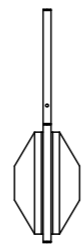

115 mm – 4.5"





Lampadaire – Floor lamp



Lampadaire – Floor lamp Link SB



## LOUIS

Collection inspirée par le célèbre artiste de jazz, les suspensions *Louis* jouent des effets de lumières avec le verre et le laiton. Modulables, créez vos compositions de « trompettes » à l'envi.



A collection inspired by the iconic jazz artist, the *Louis* pendants play with lighting effects on the glass and the brass. Adjustable, you can arrange the “trumpets” as you wish.

**Finitions  
Finishes**

- Laiton satiné / SB Satin brass
- Graphite satiné / SG Satin graphite
- Nickel satiné / SN Satin nickel
- Cuivre satiné / SC Satin copper
- Bronze / BZ Bronze

Détails page 287

**Nuances du verre  
Glass colors**

- Opale et écaille / Opal and patterned
- Claire et écaille / Clear and patterned
- Opale (XS uniquement) / Opal (XS only)

**Câble  
Cable**

- Tissu noir / Black textile
  - Tissu or (sur demande uniquement) / Gold textile (on request only)
- La longueur standard des câbles est de 2 mètres mais elle peut être diminuée à l'installation. The standard height of the cables is 2 meters (78.7") but can be adjusted to less during installation.

**Matériaux  
Materials**

- Laiton massif / Solid Brass
- Verrerie soufflée bouche / Mouth-blown glass
- Câble textile / Textile cable

**Source  
Lamping**

|                |         |        |      |   |                       |
|----------------|---------|--------|------|---|-----------------------|
| LED intégrée   | 1500 lm | 2700°K | 14 W | Alim. électr. intégrée dans le pavillon | Variation (phase cut) |
| Integrated LED | 1500 lm | 2700°K | 14 W | Int. power supply included in canopy    | Dimmable (phase cut)  |
| Integrated LED | 1500 lm | 2700°K | 15 W | Int. power supply included in canopy    | Not dimmable          |

Valeurs nominales / Nominal values

**Designer**

Émilie Cathelineau

**Louis XS**

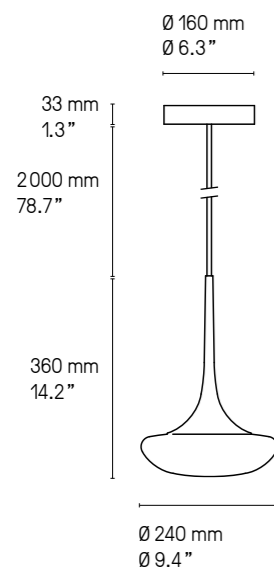

**Louis XL**

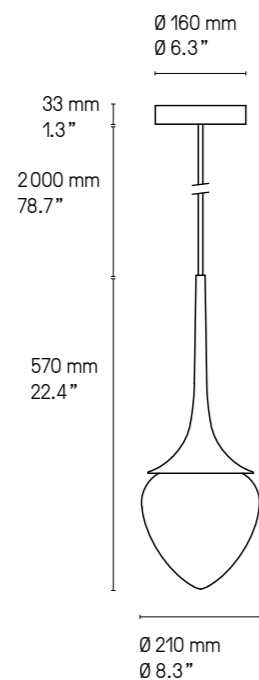

La longueur standard des câbles est de 2 m mais elle peut être diminuée à l'installation. Autres longueurs sur demande. The standard height of the cables is 2 m (78.7") but can be adjusted to less during installation. Custom heights available upon request.



**Louis XL** SB Claire et écailles – Clear and patterned  
**Louis XS** SG Claire et écailles – Clear and patterned  
**Louis XL** SB Opale et écailles – Opal and patterned

500 mm / 19.7"

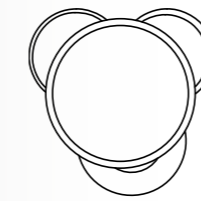

Ø 340 mm / 13.4"  
Ø 300 mm / 11.8"

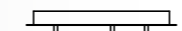

580 mm / 22.8"

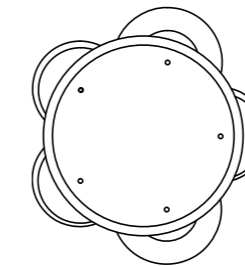

Ø 440 mm / 17.3"  
Ø 400 mm / 15.7"

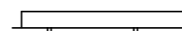

1100 mm / 43.3"

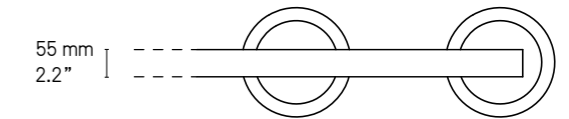

1000 mm / 39.4"

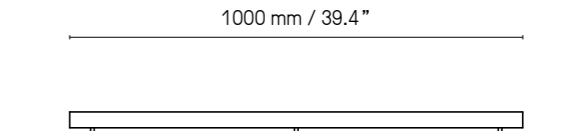
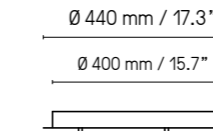
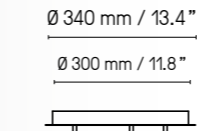
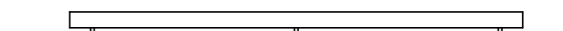

**US Version  
fitted plate to cover  
outlet power box**

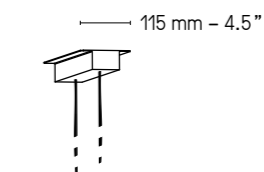

Il est possible de rassembler plusieurs suspensions sur un seul pavillon, circulaire ou rectangulaire. La version rectangulaire peut être adaptée à n'importe quelle longueur. La version circulaire a un diamètre maximum indiqué sur les croquis ci-dessus. Pour plus de renseignements, veuillez nous contacter.

It is possible to cluster several pendants from one single canopy, either rectangular or circular. The rectangular canopy can be custom-made into any size to suit your requirements. As for the circular canopy, available sizes are illustrated above. Please contact us for further information.



Louis XS SG Opale et écaille – Opal and patterned



Louis XL SB Opale et écaille – Opal and patterned



Louis XL SB Claire et écaille – Clear and patterned



## MOULURES

*Les Moulures s'inscrivent dans l'ancrage parisien de José Lévy et son héritage haussmannien. Dans un travail de « déconstruction » de ce style iconique, le designer a détourné le motif ornemental des moulures intérieures pour sculpter la base de ces appliques ou lampes à poser. En apposant une tête en verre opale à ce pied architectural, le designer amplifie le charme de ces lampes qui reprennent l'idée de forme habitée.*



*The Moulures are in keeping with José Lévy's Parisian roots and Haussmann heritage. In a work of "deconstruction" of this iconic style, the designer has used the ornamental motif of interior moldings to sculpt the base of these sconces or table lamps. By affixing an opal glass head to this architectural base, the designer amplifies the charisma of these lamps, which echo the idea of inhabited form.*

**Finitions  
Finishes**

● Laque Noire  
NO Glossy black

○ Laque Blanche  
BC Glossy white

Détails page 285

**Matériaux  
Materials**

**Tous - All**  
Laiton massif  
Solid brass

**Lampe de table - Table lamp**  
Verre triplex opale soufflé bouche  
Opal triplex mouth-blown glass

Câble textile noir  
Black textile cable

**Appliques -Wall Lights**  
Diffuseur polycarbonate satiné  
Satin Polycarbonate diff user

**Source  
Lamping**

*Valeurs nominales  
Nominal values*

**Applique - Wall light**  
LED intégrée 2700 lm 2700°K 16 W Alimentation intégrée Variable (phase cut)  
Integrated LED 2700 lm 2700°K 16 W Int.power supply included Dimmable (phase cut)

**Lampes de table - Table Lamps**

**Small & Large**  
G9 LED 5W max. non fournie Interrupteur sur câble  
G9 LED 5W max. not included Cable Switch

**Designer**

José Lévy



Lampes de Table - Table lamps  
Moulure Large BC & Small Debout BC

**Moulure Small Assise**

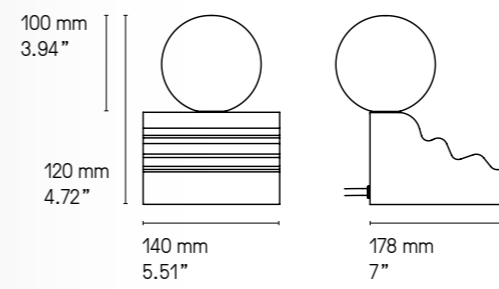

**Moulure Large**

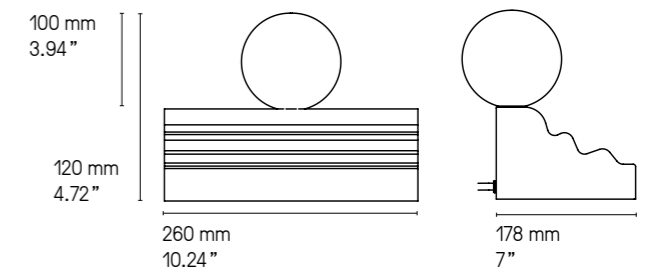

**Moulure Small Debout**

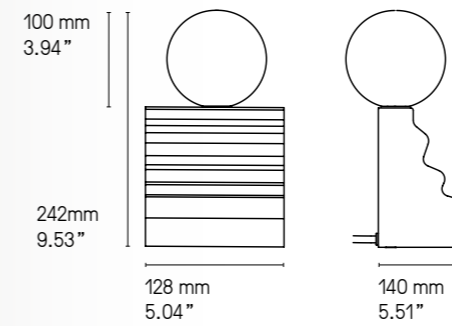

Lampe de table - Table lamp  
Moulure Small Assise NO

Applique-Wall light Moulure

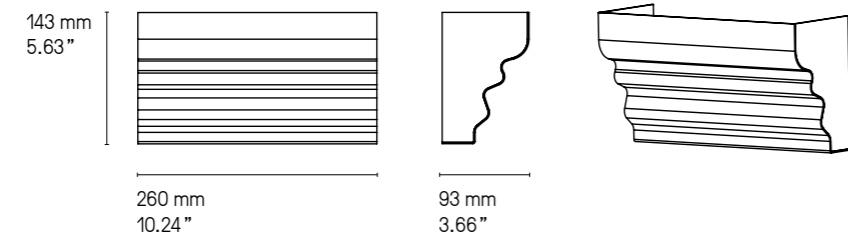

Applique - Wall light Moulure BC



Applique - Wall light Moulure BC  
Lampe de table - Table lamp Moulure Large BC



## NABOO

Pensée pour les têtes de lit ou les espaces de détente, la collection *Naboo* propose une approche modulable du confort lumineux. Déclinée en plusieurs versions – avec ou sans spot orientable, avec diffuseur ou réflecteur – elle s’adapte à tous les besoins d’usage et d’ambiance. Une lumière douce, ciblée ou indirecte selon la configuration choisie.



Designed for headboards or relaxation areas, the *Naboo* collection offers a modular approach to lighting comfort. Available in several versions – with or without an adjustable spotlight, with diffuser or reflector – it adapts to all needs in terms of use and atmosphere. A soft, focused, or indirect light, depending on the chosen configuration.

**Finitions** ① + ②  
**Finishes**

Détails page 285

|                                    |   |                                     |                                     |                       |
|------------------------------------|---|-------------------------------------|-------------------------------------|-----------------------|
| ● Laiton satiné<br>SB Satin brass  | ● Graphite satiné<br>SG Satin graphite  | ● Nickel satiné<br>SN Satin nickel  | ● Cuivre satiné<br>SC Satin copper  | ● Bronze<br>BZ Bronze |
| ● Laiton poli<br>PB Polished brass | ● Graphite poli<br>PG Polished graphite | ● Nickel poli<br>PN Polished nickel | ● Cuivre poli<br>PC Polished copper |                       |

**Matériaux**  
**Materials**

|                              |   |
|------------------------------|---|
| Laiton massif<br>Solid brass | Diffuseur polycarbonate<br>Polycarbonate diffuser |
|------------------------------|---|

**Source**  
**Lamping**

Valeurs nominales  
 Nominal values

|   |                 |        |    |                              |                      |
|---|-----------------|--------|----|------------------------------|----------------------|
| <b>Naboo Diffuseur – Diffuser</b>                 |                 |        |    |                              |                      |
| LED intégrée                                      | 500 lm          | 2700°K | 4W | Alimentation intégrée        | Interrupteur ON/OFF  |
| Integrated LED                                    | 500 lm          | 2700°K | 4W | Int. power supply included   | Switch ON/OFF        |
| <b>Naboo Réflecteur – Reflector</b>               |                 |        |    |                              |                      |
| LED intégrée                                      | 500 lm          | 2700°K | 4W | Alimentation intégrée        | Interrupteur ON/OFF  |
| Integrated LED                                    | 500 lm          | 2700°K | 4W | Int. power supply included   | Switch ON/OFF        |
| <b>Naboo Diffuseur + Spot – Diffuser + Spot</b>   |                 |        |    |                              |                      |
| LED intégrée                                      | 500 lm + 350 lm | 2700°K | 7W | Alimentations intégrées      | Interrupteurs ON/OFF |
| Integrated LED                                    | 500 lm + 350 lm | 2700°K | 7W | Int. power supplies included | Switches ON/OFF      |
| <b>Naboo Réflecteur + Spot – Reflector + Spot</b> |                 |        |    |                              |                      |
| LED intégrée                                      | 500 lm + 350 lm | 2700°K | 7W | Alimentations intégrées      | Interrupteurs ON/OFF |
| Integrated LED                                    | 500 lm + 350 lm | 2700°K | 7W | Int. power supplies included | Switches ON/OFF      |

**Designer** Émilie Cathelineau



Naboo Diffuseur VS SN    Naboo Réflecteur VS SB    Naboo Diffuseur + Spot VS SG    Naboo Réflecteur + Spot VS SB

**Naboo Diffuseur – Diffuser**

**VS: Version socle**  
**Base-mounted version**

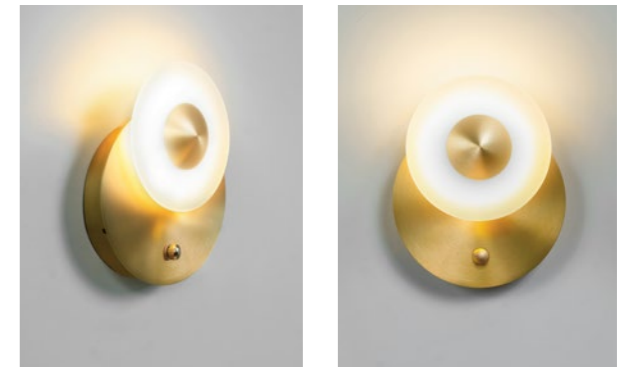
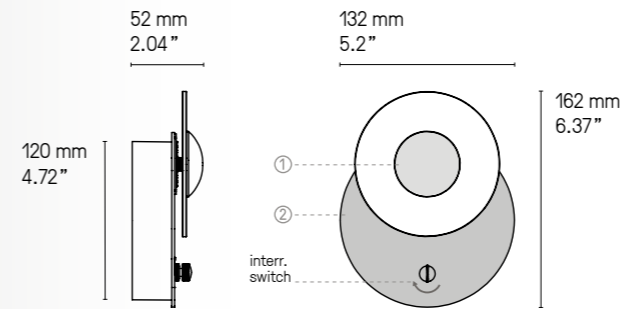

Naboo Diffuseur VS SB    Naboo Diffuseur VS SB

**VE: Version encastrable**  
**Recessed version**

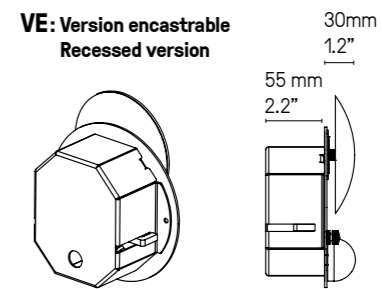

Naboo Diffuseur VE SB

**Naboo Réflecteur – Reflector**

**VS: Version socle**  
**Base-mounted version**

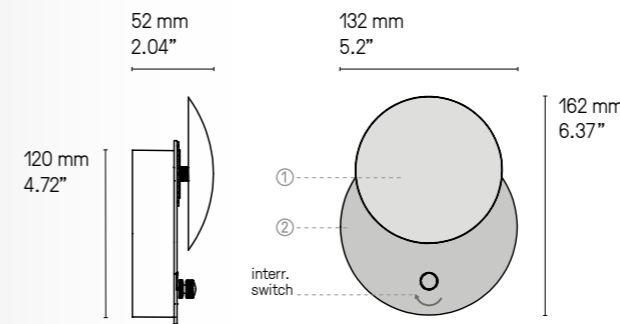

Naboo Réflecteur VS SB    Naboo Réflecteur VS SB/SG

**VE: Version encastrable**  
**Recessed version**

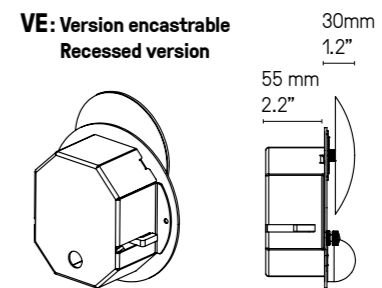

Naboo Réflecteur VE SB

**Naboo Diffuseur + Spot – Diffuser + Spot**

**VS: Version socle  
Base-mounted version**

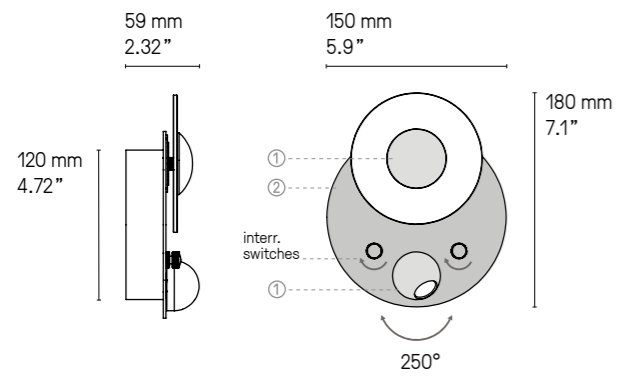

Naboo Diffuseur + Spot VS SB Naboo Diffuseur + Spot VS SN

**VE: Version encastrable  
Recessed version**

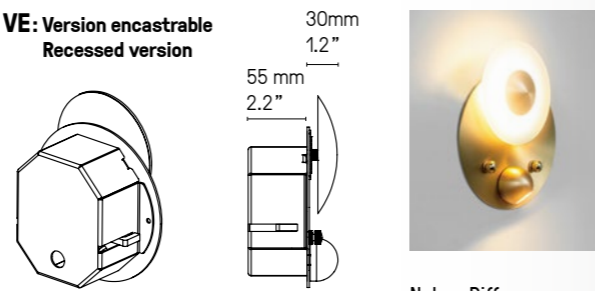

Naboo Diffuseur + Spot VE SB

**Naboo Réflecteur + Spot – Reflector + Spot**

**VS: Version socle  
Base-mounted version**

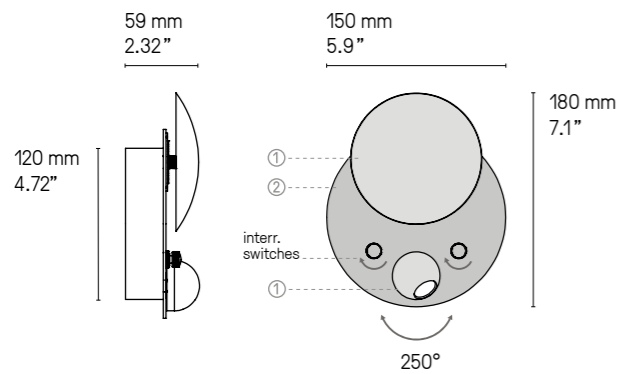

Naboo Réflecteur + Spot VS SB Naboo Réflecteur + Spot VS SC

**VE: Version encastrable  
Recessed version**

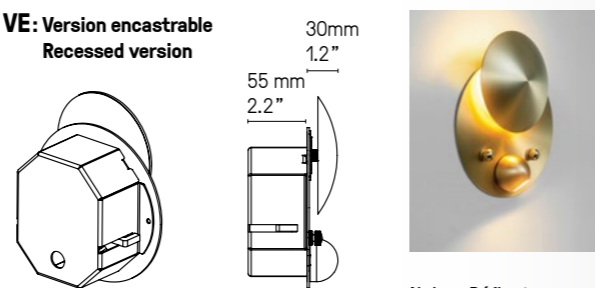

Naboo Réflecteur + Spot VE SB

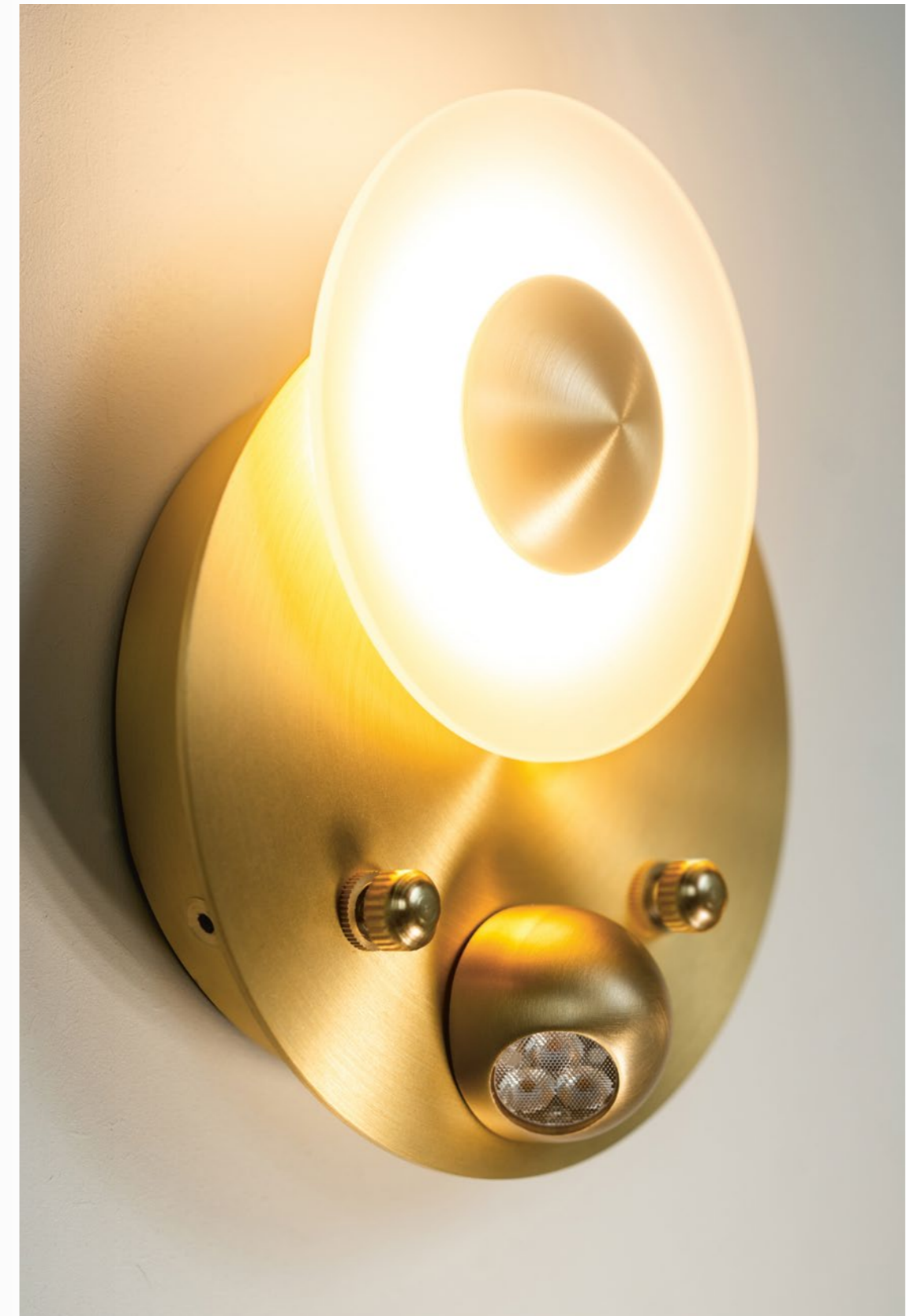

Naboo Diffuseur + Spot VS SB

**Naboo Diffuseur + Spot + USB-C – Diffuser + Spot + USB-C**

**VE: Version encastrable**  
Recessed version

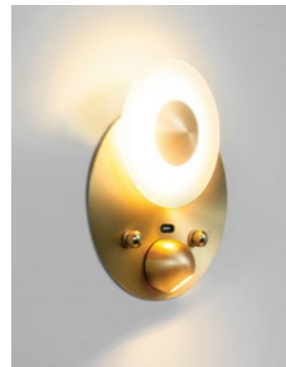
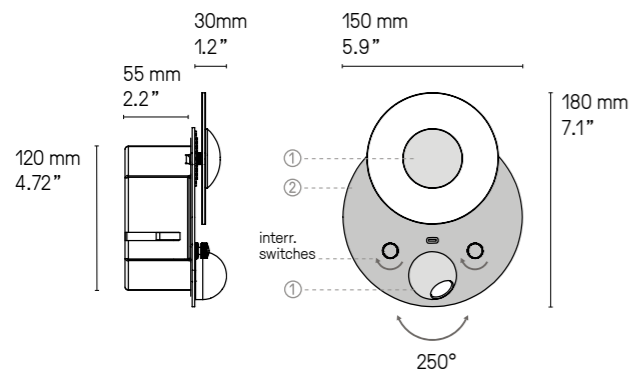

Naboo Diffuseur + Spot + USB-C  
VE/SB



Naboo Diffuseur + Spot + USB-C  
VE/SB

**Naboo Réflecteur + Spot + USB-C – Reflector + Spot + USB-C**

**VE: Version encastrable**  
Recessed version

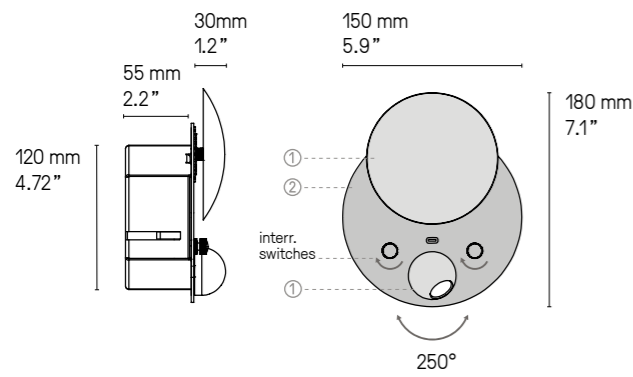

Naboo Réflecteur + Spot + USB-C  
VE/SB



Naboo Réflecteur + Spot + USB-C  
VE/SG

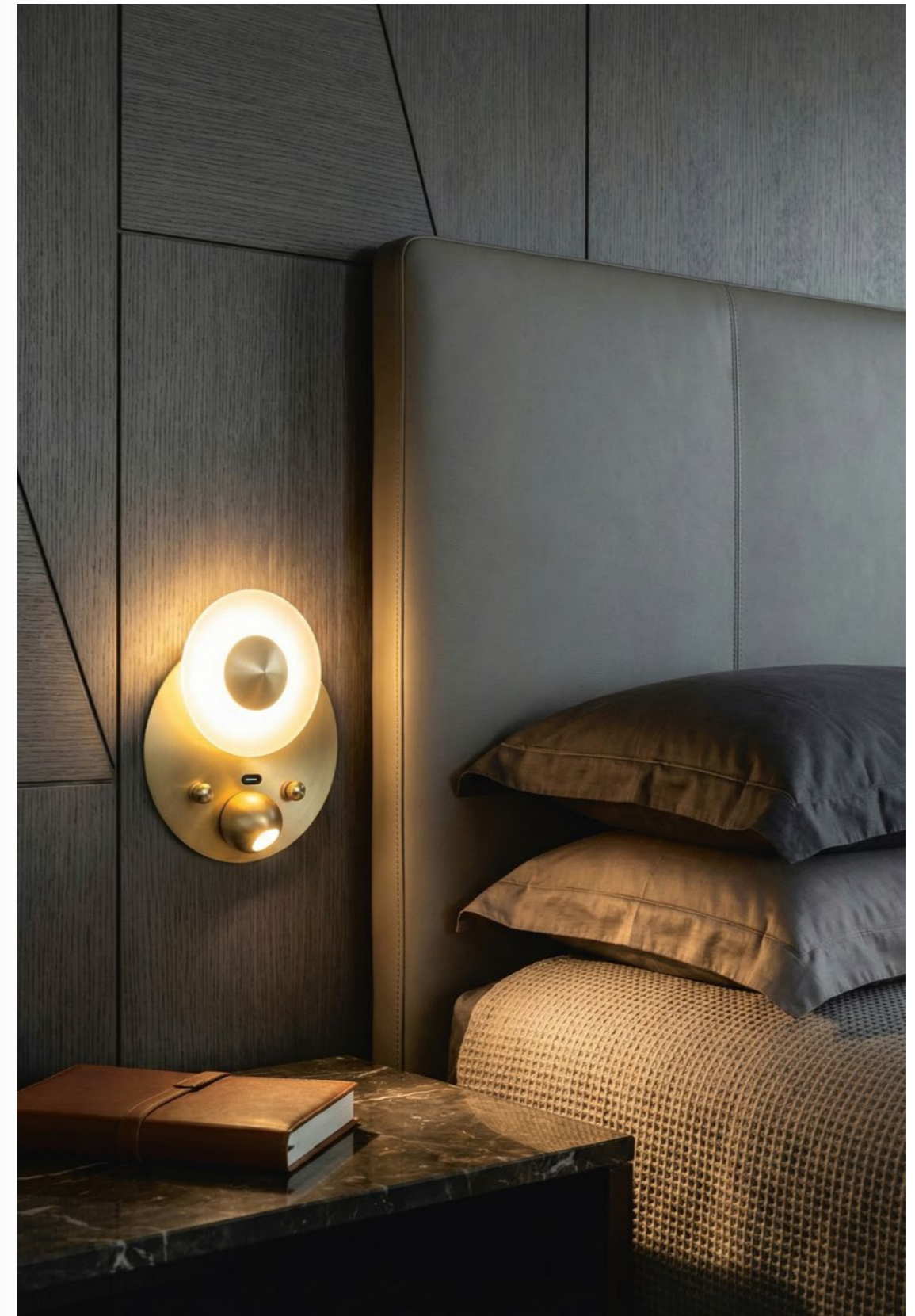

Naboo Diffuseur + Spot + USB-C VE/SB



## NACHO

Inspiré de peintures, et tout droit sorti du langage graphique imaginaire de Sylvain Willenz, *Nacho* rassemble sur une même ligne divers éléments sculpturaux et lumineux.



Inspired by paintings, and straight out of the imaginary graphic language of Sylvain Willenz, *Nacho* gathers along one single line, various sculptural and lighting elements.

**Finitions**  
**Finishes** ① + ② + ③

Détails page 285

- Laiton satiné  
SB Satin brass
- Graphite satiné  
SG Satin graphite
- Nickel satiné  
SN Satin nickel
- Cuivre satiné  
SC Satin copper
- Bronze  
BZ Bronze

**Matériaux**  
**Materials**

- Laiton massif  
Solid Brass
- Verre opale  
Opal glass
- Diffuseur polycarbonate satiné  
Satin Polycarbonate diffuser
- Câble métallique gainé  
Sheathed metal cable

*La longueur standard des câbles est de 2 mètres mais elle peut être diminuée à l'installation.  
The standard height of the cables is 2 meters (78.7") but can be adjusted to less during installation.*

**Source**  
**Lamping**

Valeurs nominales  
Nominal values

**Nacho 1300**  
Ruban LED intégré (840 lm, 2700°K, 26W) + Non incluses : G4 LED 3W max. et 2 x GU 5.3 LED 7W max.  
Alimentations 24V et 12V intégrées dans le pavillon Variable (phase cut)  
Integrated strip LED (840 lm, 2700°K, 26W) + Not included: G4 LED 3W max. and 2 x GU 5.3 LED 7W max.  
Internal power supplies 24V and 12V included in canopy Dimmable (phase cut)

**Nacho 750**  
Ruban LED intégré (670 lm, 2700°K, 20W) + Non incluses : 2 x G4 LED 3W max.  
Alimentations 24V et 12V intégrées dans le pavillon Variable (phase cut)  
Integrated strip LED (670 lm, 2700°K, 20W) + Not included: 2 x G4 LED 3W max.  
Internal power supplies 24V and 12V included in canopy Dimmable (phase cut)

**Designer**

Sylvain Willenz



Nacho 1300 SB/SB/SG

**US Version**  
**fitted plate to cover**  
**outlet power box**

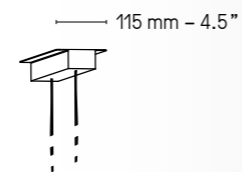

**Nacho 750**

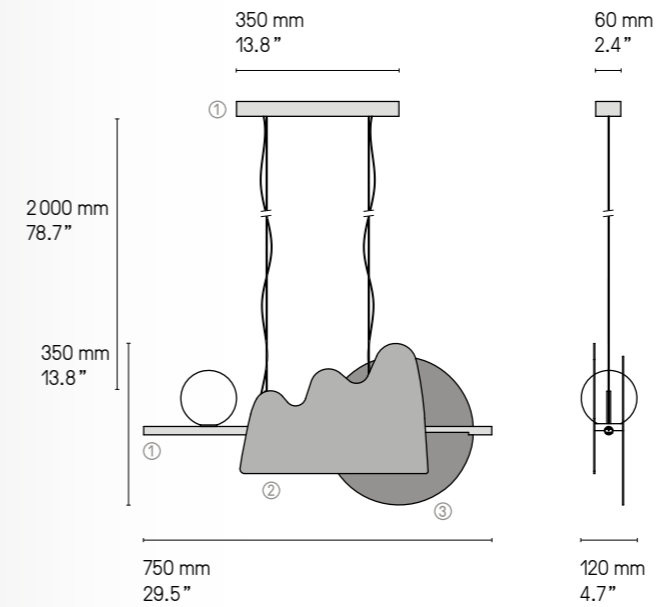

Nacho 750 SG/SG/SB

**Nacho 1300**

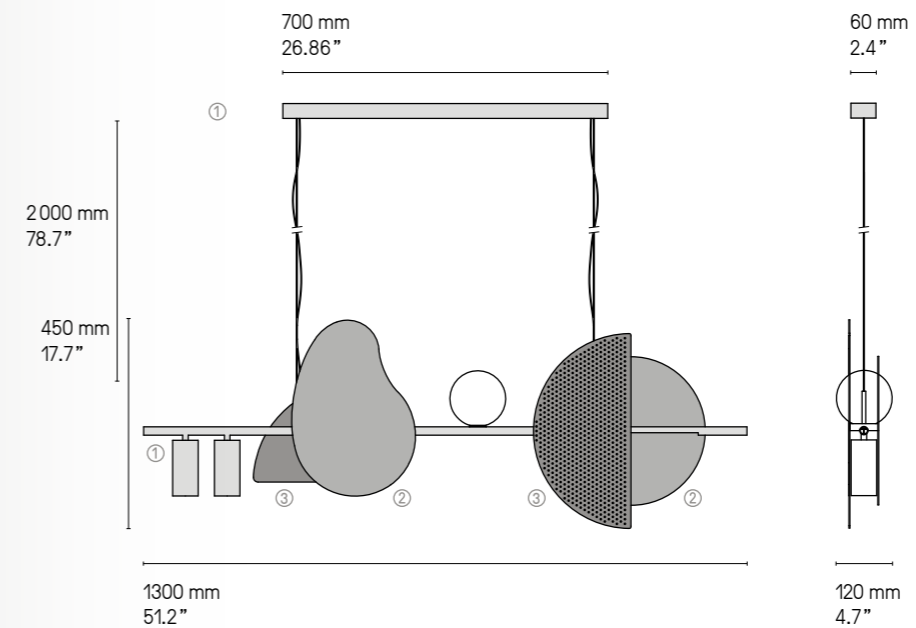

Nacho 1300 SB/SG/SB

*La longueur standard des câbles est de 2 m mais elle peut être diminuée à l'installation. Autres longueurs sur demande.  
The standard height of the cables is 2 m (78.7") but can be adjusted to less during installation. Custom heights available upon request.*



## PARADOXE

Le lustre *Paradoxe* est une réinterprétation moderne du lustre classique. Élégant et audacieux, il revisite le luminaire traditionnel avec une inversion lumineuse unique : ici, la lumière émane des bras du lustre, tandis que les tubes en laiton évoquent les bougies d'antan.



The *Paradoxe* chandelier is a modern reinterpretation of the classic chandelier. Elegant and bold, it reimagines the traditional luminaire with a unique lighting inversion. For this design, light radiates from the chandelier's arms, whereas the brass tubes resemble the candles of olden times.

**Finitions Finishes**

● Laiton satiné SB Satin brass ● Graphite satiné SG Satin graphite ● Nickel satiné SN Satin nickel ● Cuivre satiné SC Satin copper ● Bronze BZ Bronze

Détails page 285

**Matériaux Materials**

Laiton massif Solid brass Silicone Silicone Câble acier noir Black steel cable

| Source Lamping | Paradoxe 3L |        |      |  |                      |
|----------------|-------------|--------|------|--|----------------------|
| LED intégrée   | 1300 lm     | 2700°K | 23W  |  | Variable (phase cut) |
| Integrated LED | 1300 lm     | 2700°K | 23W  |  | Dimmable (phase cut) |
|                | Paradoxe 5L |        |      |  |                      |
| LED intégrée   | 2800 lm     | 2700°K | 49W  |  | Variable (phase cut) |
| Integrated LED | 2800 lm     | 2700°K | 49W  |  | Dimmable (phase cut) |
|                | Paradoxe 6L |        |      |  |                      |
| LED intégrée   | 4800 lm     | 2700°K | 82W  |  | Variable (phase cut) |
| Integrated LED | 4800 lm     | 2700°K | 82W  |  | Dimmable (phase cut) |
|                | Paradoxe 8L |        |      |  |                      |
| LED intégrée   | 10300 lm    | 2700°K | 222W |  | Variable (phase cut) |
| Integrated LED | 10300 lm    | 2700°K | 222W |  | Dimmable (phase cut) |

**Designer** Émilie Cathelineau



Paradoxe 3L Fixe - Stem version SB

**Paradoxe 3L**

**Paradoxe 3L Fixe - Stem version**

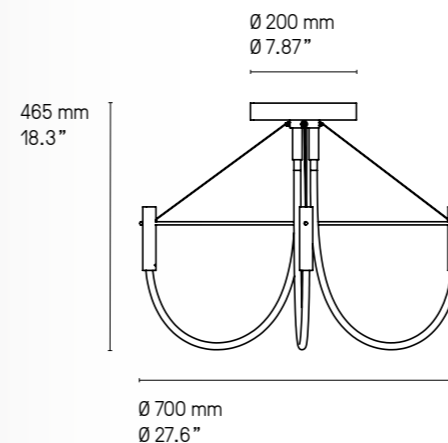

**Paradoxe 3L Chaîne - Chain version**

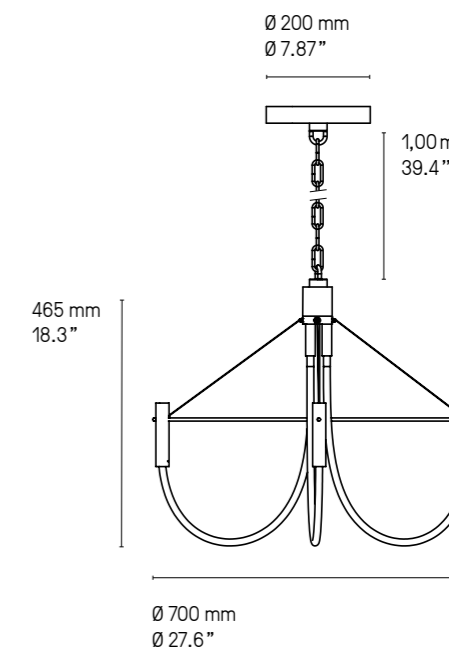

La hauteur minimum de la suspension est de 645 mm mais nous la fournissons à 1495 mm.  
The minimum height of the pendant is 25.4" but we supply a height of 58.9".



Paradoxe 3L chaîne - Chain version SB



Paradoxe 5L Chaîne – Chain SB

**Paradoxe 5L**

**Paradoxe 5L Fixe – Stem version**

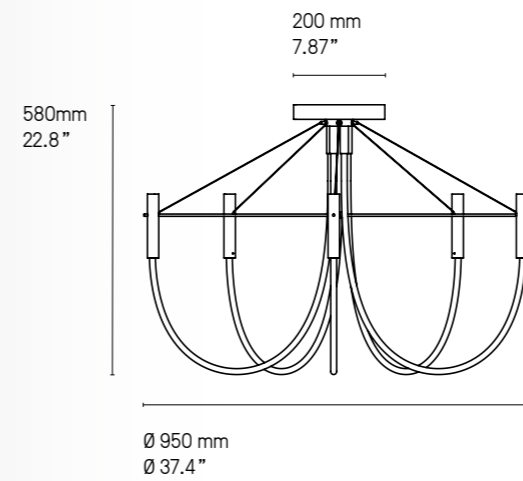

**Paradoxe 5L Chaîne – Chain version**

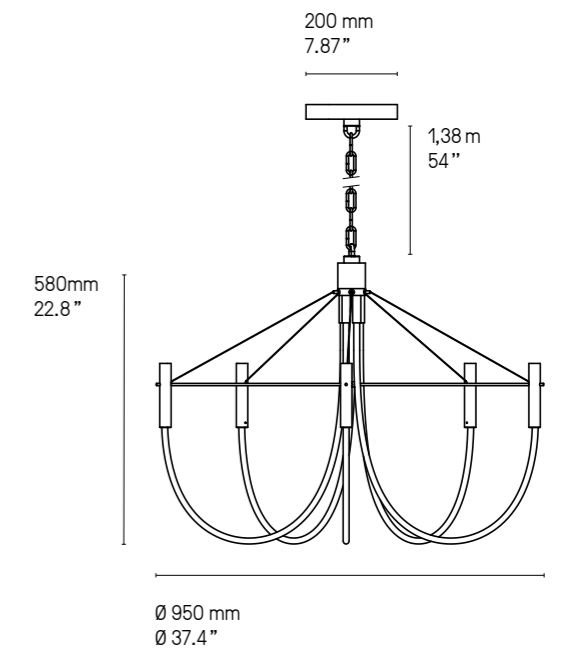

La hauteur minimum de la suspension est de 760 mm  
mais nous la fournissons à 1990 mm.  
The minimum height of the pendant is 29.9"  
but we supply a height of 78.4".



Paradoxe 5L Fixe – Stem version SG

Paradoxe 6L Fixe – Stem version

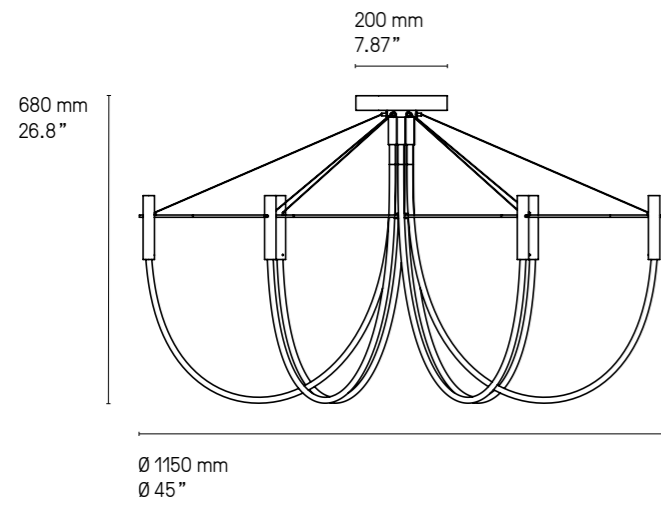

Paradoxe 6L Chaîne – Chain version

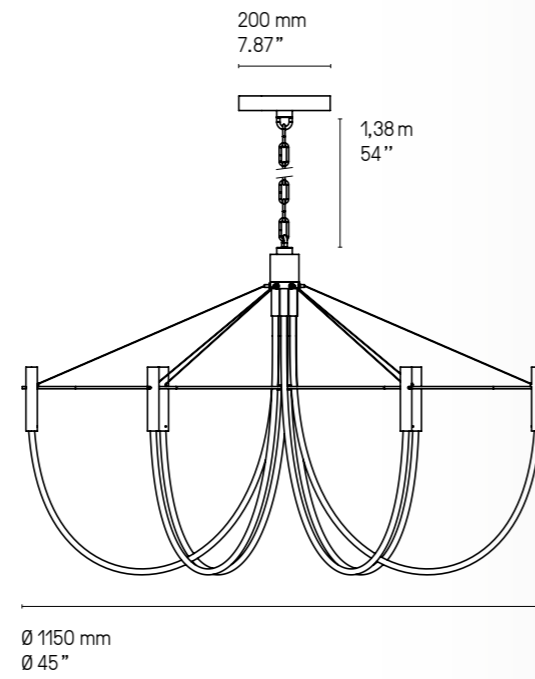

La hauteur minimum de la suspension est de 860 mm  
mais nous la fournissons à 2090 mm.  
The minimum height of the pendant is 33.8"  
but we supply a height of 82.3".



Paradoxe 6L Chaîne – Chain version SB

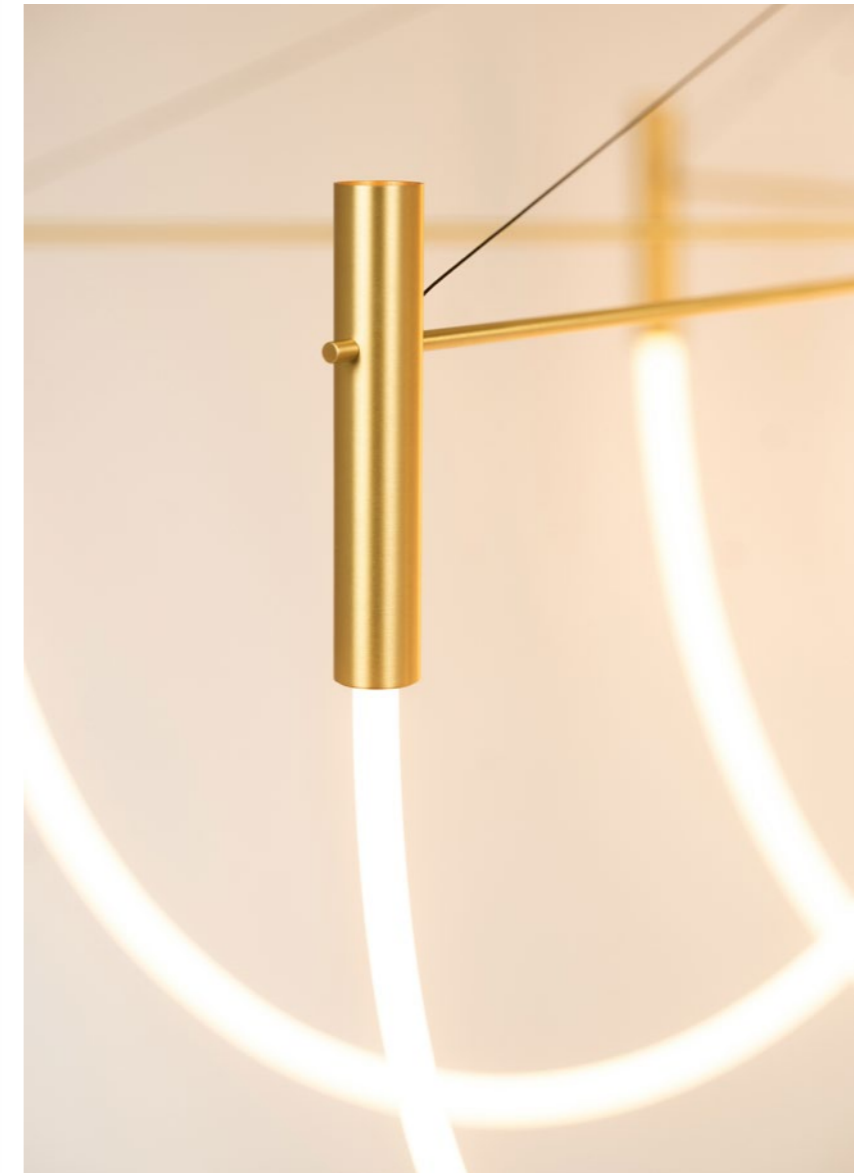

Paradoxe SB

Paradoxe 8L Fixe – Stem version

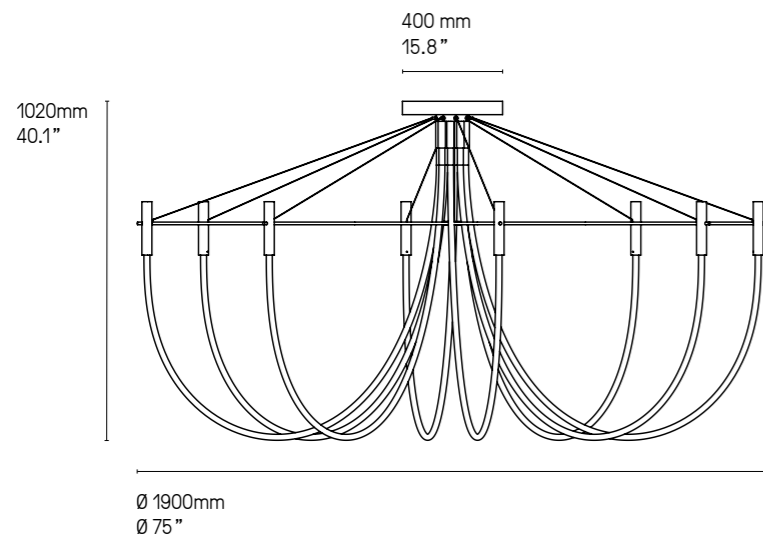

Paradoxe 8L Fixe – Stem version SG

Paradoxe 8L Chaîne – Chain version

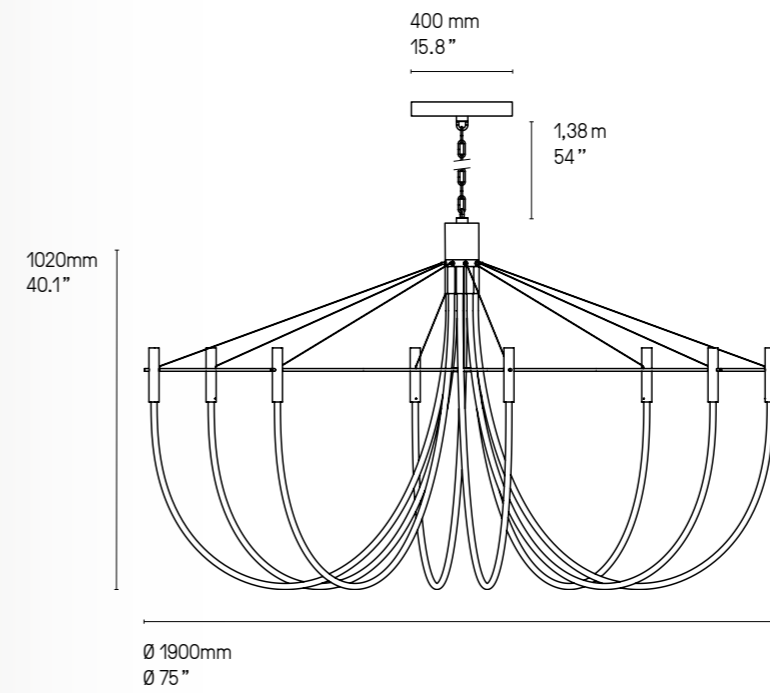

La hauteur minimum de la suspension est de 1220 mm mais nous la fournissons à 2440 mm.  
The minimum height of the pendant is 48" but we supply a height of 96.1".



Paradoxe 8L Chaîne – Chain version SB





## PIROUETTE

*Pirouette* est une petite applique singulière, à la fois décorative et fonctionnelle. La rotation à 360° de son faisceau lumineux et sa variation tactile en font une applique de chevet idéale. Elle trouvera également sa place en répétition dans un couloir pour guider le passage.



*Pirouette* is a unique little wall lamp, both decorative and functional. The 360° rotation of its light beam and its touch-sensitive dimmer make it an ideal bedside wall lamp. Several positioned along a corridor will also provide useful lighting.

**Finitions** ①+②

|                       |                          |                        |                        |                  |
|-----------------------|--------------------------|------------------------|------------------------|------------------|
| ● Laiton satiné       | ● Graphite satiné        | ● Nickel satiné        | ● Cuivre satiné        | ● Bronze         |
| <b>SB</b> Satin brass | <b>SG</b> Satin graphite | <b>SN</b> Satin nickel | <b>SC</b> Satin copper | <b>BZ</b> Bronze |

Détails page 285

**Matériaux** Laiton massif  
**Material** Solid Brass

**Source Lamping** Pirouette V1 & V2  
LED intégrée 417 lm 2700°K 5W Alim. électronique 24V intégrée Variateur tactile  
Integrated LED 417 lm 2700°K 5W Int. power supply 24V included Touch dimmer

Valeurs nominales  
Nominal power

**Designer** Émilie Cathelineau

**US Version**  
fitted plate to cover  
outlet power box

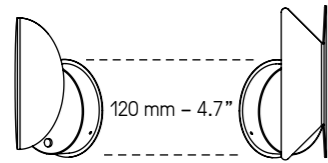

Variateur tactile – Touch dimmer



Pirouette V1 SB/SB



Pirouette V1 SG/SB

**Pirouette V1**

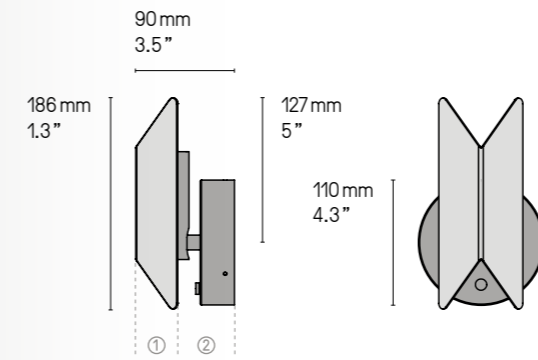

Pirouette V1 SG/SG

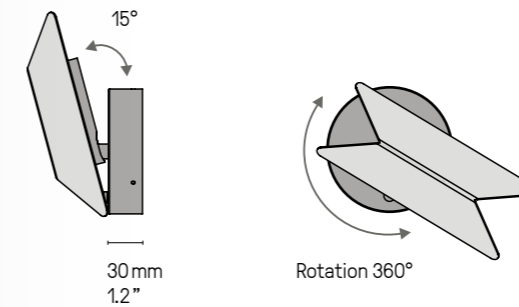

Pirouette V1 SB/SB

**Pirouette V2**

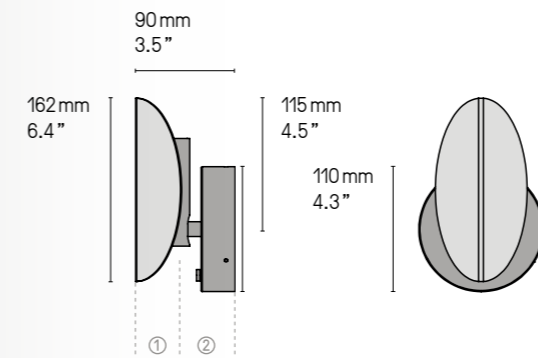

Pirouette V2 SG/SB

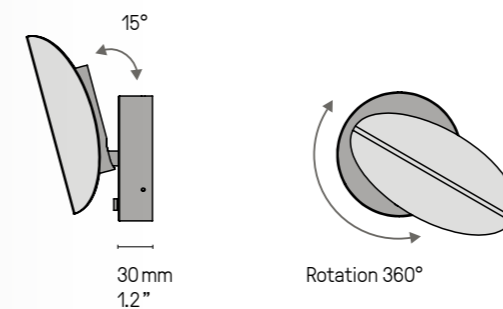

Pirouette V2 SB/SB



## RUBAN

La collection *Ruban* met en avant la douceur du tissu et l'élégance discrète du laiton brossé ou poli. Chaque lampe est dotée d'un abat-jour en rubans de tissu plissés, diffusant une lumière agréable et apaisante.

Déclinées en plusieurs tailles, elles s'intègrent facilement dans différents espaces et peuvent être utilisées seules ou en composition, notamment comme lampes de chevet.



The *Ruban* collection highlights the softness of fabric and the understated elegance of brushed or polished brass. Each lamp features a pleated fabric ribbon lampshade, diffusing a pleasant and soothing light.

Available in a range of sizes, they blend easily into different spaces and can be used on their own or in arrangements, particularly as bedside lamps.

**Finitions**  
**Finishes**

Détails page 285

|                                    |   |                                     |                                     |                       |
|------------------------------------|---|-------------------------------------|-------------------------------------|-----------------------|
| ● Laiton satiné<br>SB Satin brass  | ● Graphite satiné<br>SG Satin graphite  | ● Nickel satiné<br>SN Satin nickel  | ● Cuivre satiné<br>SC Satin copper  | ● Bronze<br>BZ Bronze |
| ● Laiton poli<br>PB Polished brass | ● Graphite poli<br>PG Polished graphite | ● Nickel poli<br>PN Polished nickel | ● Cuivre poli<br>PC Polished copper |                       |

**Matériaux**  
**Material**

|                                 |                                      |   |
|---------------------------------|--------------------------------------|---|
| Laiton massif<br>Solid brass or | Abat-jour tissu<br>Textile lampshade | Câble textile noir<br>Black textile cable |
|---------------------------------|--------------------------------------|---|

**Source**  
**Lamping**

Valeurs nominales  
Nominal power

|                               |                        |            |
|-------------------------------|------------------------|------------|
| Lampes de table – Table Lamps |                        |            |
| E14 LED 8W max. non fournie   | Interrupteur sur câble | Variation* |
| E14 LED 8W max. not included  | Cable Switch           | Dimmable*  |
| E12 LED 8W max. not included  | Cable Switch           | Dimmable*  |

**Designer**

Émilie Cathelineau

\* Les luminaires variables nécessitent l'utilisation d'ampoules compatibles avec la variation.  
All dimmable light fixtures require the use of compatible bulbs.

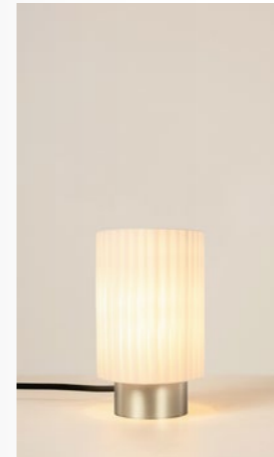

Ruban 07-14 SN



Ruban 07-20 PG



Ruban 10-20 SG



Ruban 10-28 SB



Ruban 10-28 SN

**Ruban 07-14**

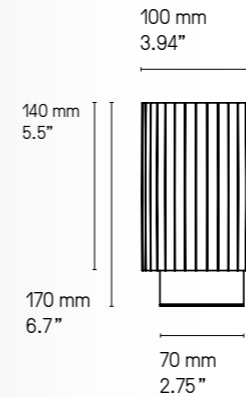

**Ruban 07-20**

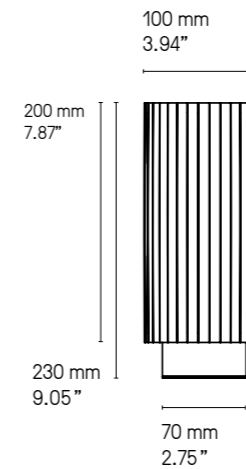

**Ruban 10-20**

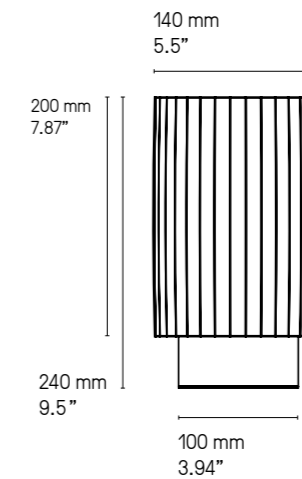

**Ruban 10-28**

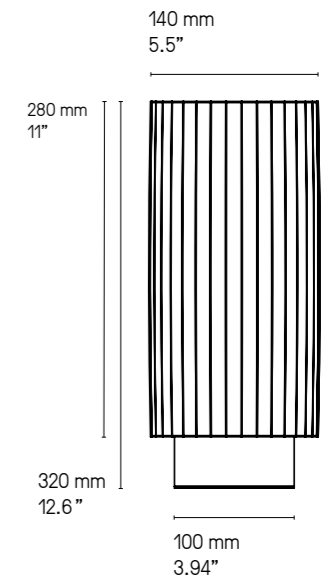



## SATURNE

La sphère lumineuse est ici prétexte au voyage dans le système solaire. Munie d'un anneau en laiton orientable, la suspension *Saturne* devient le reflet de votre vision du cosmos.



For this particular light, the luminous sphere is a representation of the solar system. Provided with a rotating brass ring, the *Saturne* pendant becomes your vision of the cosmos.

**Finitions**  
**Finishes**

● Laiton satiné  
**SB** Satin brass

● Graphite satiné  
**SG** Satin graphite

● Nickel satiné  
**SN** Satin nickel

● Cuivre satiné  
**SC** Satin copper

● Bronze  
**BZ** Bronze

Détails page 285

**Matériaux**  
**Materials**

Laiton massif  
 Solid Brass

Verrerie opale soufflée bouche  
 Opal mouth-blown glass

Câble textile (longueur ≈ 2 m)  
 Textile cable (length ≈ 78.7")

**Câble**  
**Cable**

■ Tissu noir  
 Black textile

■ Tissu or (sur demande uniquement)  
 Gold textile (on request only)

*La longueur standard des câbles est de 2 mètres mais elle peut être diminuée à l'installation.  
 The standard height of the cables is 2 meters (78.7") but can be adjusted to less during installation.*

**Source**  
**Lamping**

*Valeurs nominales  
 Nominal values*

| XL   |         | XS     |      |                                    |                                       |  |  |
|--|---------|--------|------|------------------------------------|---------------------------------------|--|--|
| LED intégrée   | 1500 lm | 2700°K | 14 W | Alimentation int. dans le pavillon | Variation (phase cut)                 |  |  |
| Integrated LED   | 1500 lm | 2700°K | 14 W | Int. power supply incl. in canopy  | Dimmable (phase cut)                  |  |  |
|  Integrated LED | 1500 lm | 2700°K | 14 W | Int. power supply incl. in canopy  | Not dimmable                          |  |  |
| XS   |         |        |      |                                    |                                       |  |  |
| LED intégrée   | 800 lm  | 2700°K | 8 W  | Alimentation int. dans le pavillon | Variation (phase cut)                 |  |  |
| Integrated LED   | 800 lm  | 2700°K | 8 W  | Int. power supply incl. in canopy  | Dimmable (phase cut), except for 110V |  |  |

**Designer**

Hervé Langlais

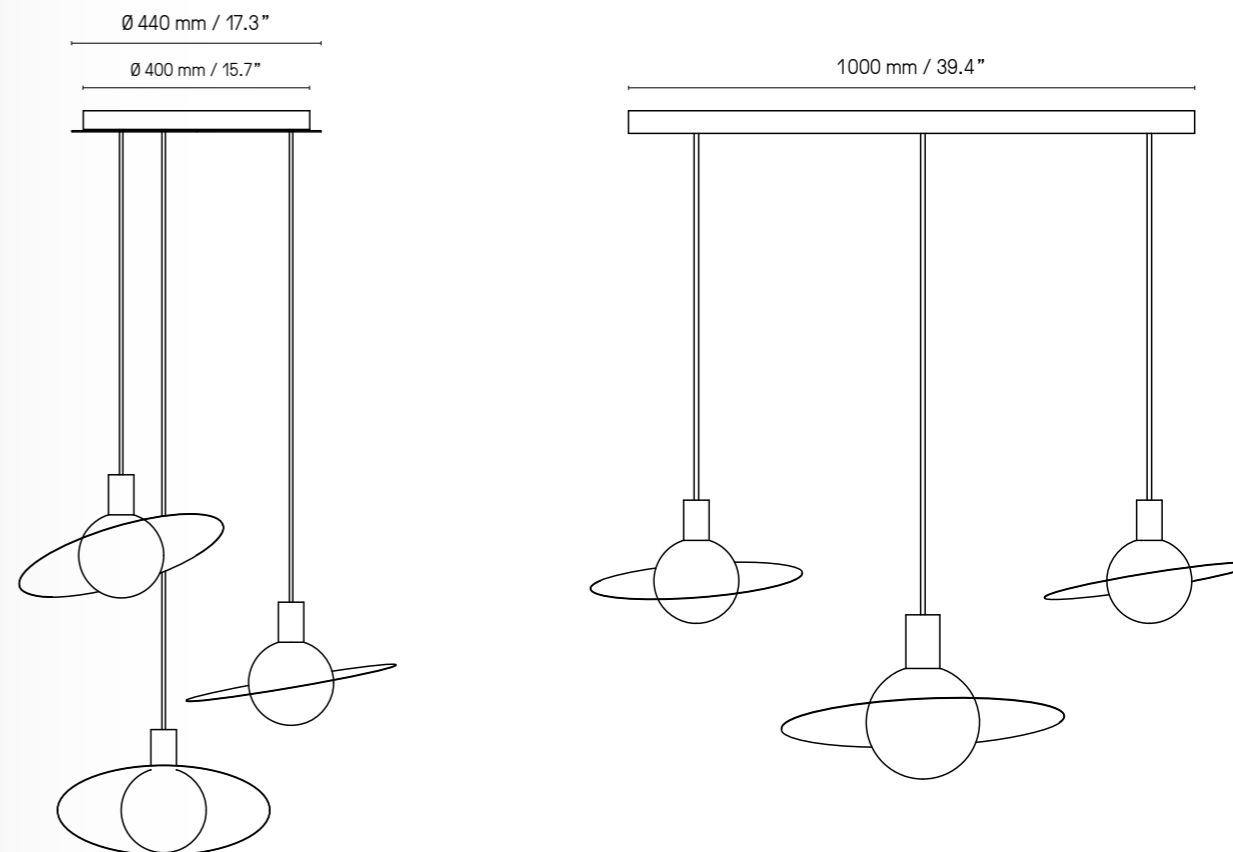

**Saturne XL**

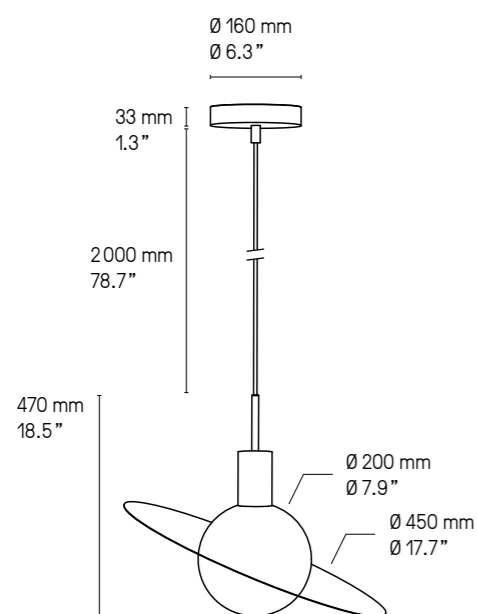

**Saturne XS (not dimmable for 110V)**

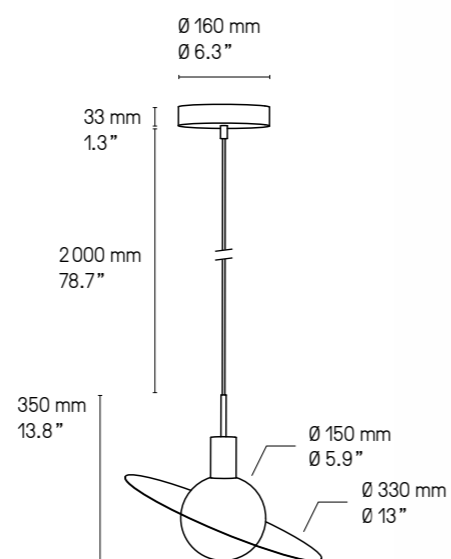

La longueur standard des câbles est de 2 m mais elle peut être diminuée à l'installation. Autres longueurs sur demande.  
 The standard height of the cables is 2 m (78.7") but can be adjusted to less during installation. Custom heights available upon request.



Saturne XL SB

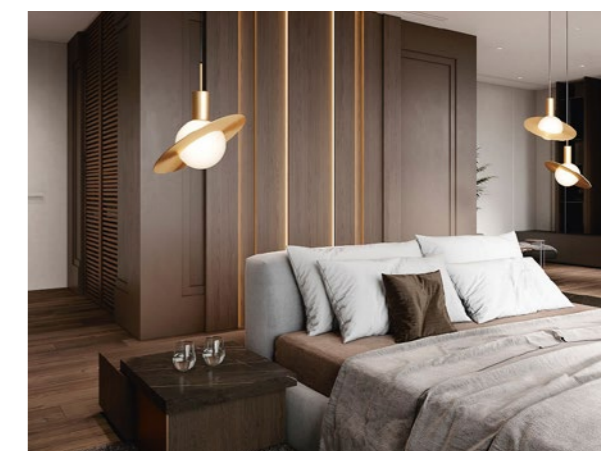

Saturne XL & XS SB

Il est possible de rassembler plusieurs suspensions sur un seul pavillon, circulaire ou rectangulaire. La version rectangulaire peut être adaptée à n'importe quelle longueur. La version circulaire a un diamètre maximum indiqué sur les croquis ci-dessus. Pour plus de renseignements, veuillez nous contacter.

It is possible to cluster several pendants from one single canopy, either rectangular or circular. The rectangular canopy can be custom-made into any size to suit your requirements. As for the circular canopy, available sizes are illustrated above. Please contact us for further information.



## SCALA

Applique murale en laiton, inspirée d'un langage architectural minimaliste. Son design joue sur l'emboîtement de tubes aux proportions variées, créant un rythme de volumes à la fois structuré et élégant. Le diffuseur en polycarbonate opalin adoucit la lumière, pour une présence à la fois graphique et discrète.



Brass wall light, inspired by a minimalist architectural language. Its design plays with the interlocking of tubes in varied proportions, creating a rhythm of volumes that is both structured and elegant. The opaline polycarbonate diffuser softens the light, giving it a presence that is both graphic and discreet.

|  |                          |                             |                           |                           |                  |
|--|--------------------------|-----------------------------|---------------------------|---------------------------|------------------|
| <b>Finitions</b><br><b>Finishes</b><br><i>Détails page 285</i> | Laiton satiné            | Graphite satiné             | Nickel satiné             | Cuivre satiné             | Bronze           |
|  | <b>SB</b> Satin brass    | <b>SG</b> Satin graphite    | <b>SN</b> Satin nickel    | <b>SC</b> Satin copper    | <b>BZ</b> Bronze |
|  | Laiton poli              | Graphite poli               | Nickel poli               | Cuivre poli               |                  |
|  | <b>PB</b> Polished brass | <b>PG</b> Polished graphite | <b>PN</b> Polished nickel | <b>PC</b> Polished copper |                  |

|                                      |  |  |
|--------------------------------------|--|--|
| <b>Matériaux</b><br><b>Materials</b> | Laiton massif<br>Solid brass   | Diffuseur polycarbonate<br>Polycarbonate diff user |
| <b>Source</b><br><b>Lamping</b>      | Applique – Wall light<br>G9 LED 5W max. non fournie<br>G9 LED 5W max. not included | Variation*<br>Dimmable*                            |
| <b>Designer</b>                      | Émilie Cathelineau   |  |

\* Les luminaires variables nécessitent l'utilisation d'ampoules compatibles avec la variation.  
All dimmable light fixtures require the use of compatible bulbs.

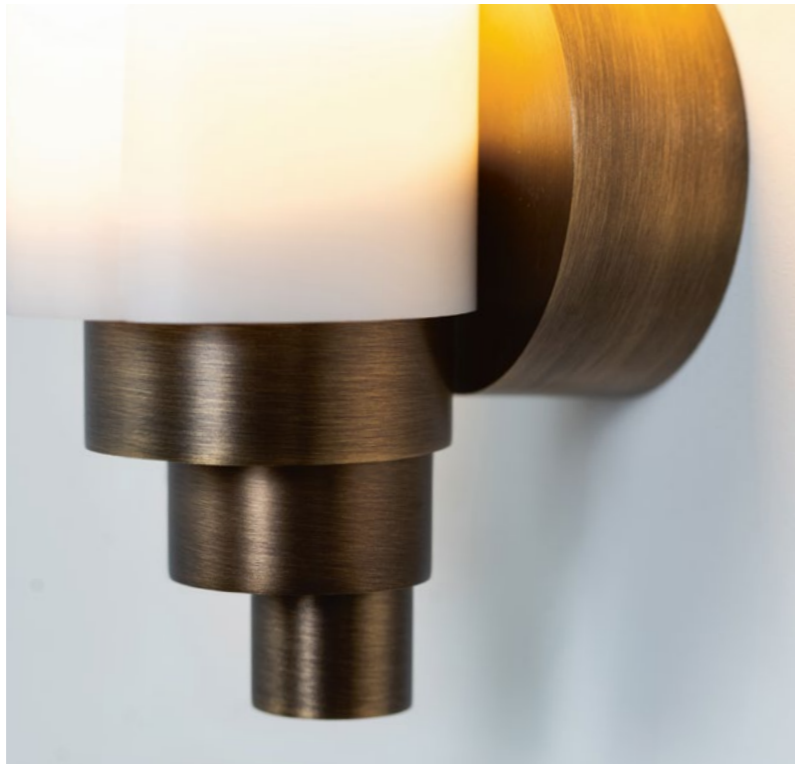

Détail Scala BZ

**SCALA**

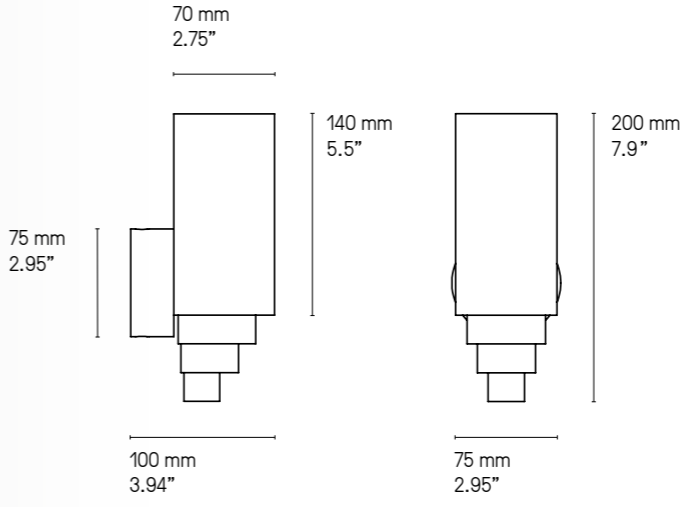

**US version**  
fitted plate to cover  
outlet power box

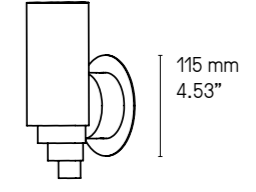

Scala PB



Scala SN



Scala SG



## SIGNAL



Apporter des lettres de noblesse au néon d'antan, voici l'esprit de la collection *Signal*. Véritable clin d'œil élégant, l'originalité de la source lumineuse désaxée se décline en appliques, suspensions et lampadaires.



Bringing something ancient back to fashion, this is what Pauline had in mind for the *Signal* collection. An elegant allusion, declined in wall lights, pendants and floor lamps, with their original asymmetric light source.

## Finitions Finishes

Détails page 285

|   |  |  |   |  |
|---|--|--|---|--|
|  Laiton satiné<br><b>SB</b> Satin brass  |  Graphite satiné<br><b>SG</b> Satin graphite  |  Nickel satiné<br><b>SN</b> Satin nickel  |  Cuivre satiné<br><b>SC</b> Satin copper  |  Bronze<br><b>BZ</b> Bronze |
|  Laiton poli<br><b>PB</b> Polished brass |  Graphite poli<br><b>PG</b> Polished graphite |  Nickel poli<br><b>PN</b> Polished nickel |  Cuivre poli<br><b>PC</b> Polished copper |  |

## Matériaux Materials

|                              |   |  |
|------------------------------|---|--|
| Laiton massif<br>Solid Brass | Diffuseur polycarbonate satiné<br>Satin Polycarbonate diff user | <b>Signal V 540, V 440, V 340</b><br>Câble textile noir (longueur ≈ 2 m)<br>Black textile cable (length ≈ 78.7")<br><b>Signal H 970, H 770</b><br>Câble métallique gainé (longueur ≈ 2 m)<br>Sheathed metal cable (length ≈ 78.7")<br><br><i>La longueur standard des câbles est de 2 mètres<br/>mais elle peut être diminuée à l'installation.<br/>The standard height of the cables is 2 meters (78.7")<br/>but can be adjusted to less during installation.</i> |
|------------------------------|---|--|







## Source Lamping

Valeurs nominales  
Nominal values

### Suspensions – Pendants

|                     |         |        |     |                                       |                      |
|---------------------|---------|--------|-----|---------------------------------------|----------------------|
| <b>Signal H 970</b> |         |        |     |                                       |                      |
| LED intégrée        | 1340 lm | 2700°K | 16W | Alim. 24V int. dans le pavillon       | Variable (phase cut) |
| Integrated LED      | 1340 lm | 2700°K | 16W | Int. power supply 24V incl. in canopy | Dimmable (phase cut) |
| <b>Signal H 770</b> |         |        |     |                                       |                      |
| LED intégrée        | 960 lm  | 2700°K | 12W | Alim. 24V int. dans le pavillon       | Variable (phase cut) |
| Integrated LED      | 960 lm  | 2700°K | 12W | Int. power supply 24V incl. in canopy | Dimmable (phase cut) |
| <b>Signal V 540</b> |         |        |     |                                       |                      |
| LED intégrée        | 770 lm  | 2700°K | 10W | Alim. 24V int. dans le pavillon       | Variable (phase cut) |
| Integrated LED      | 770 lm  | 2700°K | 10W | Int. power supply 24V incl. in canopy | Dimmable (phase cut) |
| <b>Signal V 440</b> |         |        |     |                                       |                      |
| LED intégrée        | 580 lm  | 2700°K | 8W  | Alim. 24V int. dans le pavillon       | Variable (phase cut) |
| Integrated LED      | 580 lm  | 2700°K | 8W  | Int. power supply 24V incl. in canopy | Dimmable (phase cut) |
| <b>Signal V 340</b> |         |        |     |                                       |                      |
| LED intégrée        | 380 lm  | 2700°K | 7W  | Alim. 24V int. dans le pavillon       | Variable (phase cut) |
| Integrated LED      | 380 lm  | 2700°K | 7W  | Int. power supply 24V incl. in canopy | Dimmable (phase cut) |

### Appliques – Wall lights

|  |         |        |     |                                     |                           |
|--|---------|--------|-----|-------------------------------------|---------------------------|
| <b>Signal 345 (345 mm – 13.6")</b>   |         |        |     |                                     |                           |
| LED intégrée   | 280 lm  | 2700°K | 5W  | Alimentation 24V intégrée           | Variable (phase cut)      |
| Integrated LED   | 280 lm  | 2700°K | 5W  | Int. power supply 24V included      | Dimmable (phase cut)      |
|  Integrated LED | 280 lm  | 2700°K | 5W  | Int. power supply 24V included      | Dimmable (phase cut) Damp |
| <b>Signal 445 (445 mm – 17.5")</b>   |         |        |     |                                     |                           |
| LED intégrée   | 480 lm  | 2700°K | 7W  | Alimentation 24V intégrée           | Variable (phase cut)      |
| Integrated LED   | 480 lm  | 2700°K | 7W  | Int. power supply 24V included      | Dimmable (phase cut)      |
|  Integrated LED | 480 lm  | 2700°K | 7W  | Int. power supply 24V included      | Dimmable (phase cut) Damp |
| <b>Signal 545 (545 mm – 21.5")</b>   |         |        |     |                                     |                           |
| LED intégrée   | 670 lm  | 2700°K | 9W  | Alimentation 24V intégrée           | Variable (phase cut)      |
| Integrated LED   | 670 lm  | 2700°K | 9W  | Int. power supply 24V included      | Dimmable (phase cut)      |
|  Integrated LED | 670 lm  | 2700°K | 9W  | Int. power supply 24V included      | Dimmable (phase cut) Damp |
| <b>Signal double 520 (520 mm – 20.5")</b>  |         |        |     |                                     |                           |
| LED intégrée   | 570 lm  | 2700°K | 7W  | Alimentation 24V intégrée           | Variable (phase cut)      |
| Integrated LED   | 570 lm  | 2700°K | 7W  | Int. power supply 24V included      | Dimmable (phase cut)      |
|  Integrated LED | 570 lm  | 2700°K | 7W  | Int. power supply 24V included      | Dimmable (phase cut) Damp |
| <b>Signal double 720 (720 mm – 28.4")</b>  |         |        |     |                                     |                           |
| LED intégrée   | 960 lm  | 2700°K | 13W | Alimentation 24V intégrée           | Variable (phase cut)      |
| Integrated LED   | 960 lm  | 2700°K | 13W | Int. power supply 24V included      | Dimmable (phase cut)      |
|  Integrated LED | 960 lm  | 2700°K | 13W | Int. power supply 24V included      | Dimmable (phase cut) Damp |
| <b>Signal double 920 (920 mm – 36.2")</b>  |         |        |     |                                     |                           |
| LED intégrée   | 1340 lm | 2700°K | 17W | Alimentation 24V intégrée           | Variable (phase cut)      |
| Integrated LED   | 1340 lm | 2700°K | 17W | Int. power supply 24V included Int. | Dimmable (phase cut)      |
|  Integrated LED | 1340 lm | 2700°K | 17W | power supply 24V included           | Dimmable (phase cut) Damp |

## Source Lamping

Valeurs nominales  
Nominal values

### Lampadaires – Floor lamps

|   |         |        |     |                             |                      |                  |
|---|---------|--------|-----|-----------------------------|----------------------|------------------|
| <b>Lampadaire – Floor lamp DUO</b>      |         |        |     |                             |                      |                  |
| LED intégrée                            | 2500 lm | 2700°K | 32W | Alim. 24V intégrée          | Variable (phase cut) | Variateur à pied |
| Integrated LED                          | 2500 lm | 2700°K | 32W | Int. power supply 24V incl. | Dimmable (phase cut) | Foot op. dimmer  |
| <b>Lampadaire – Floor lamp SOLO 115</b> |         |        |     |                             |                      |                  |
| LED intégrée                            | 1540 lm | 2700°K | 19W | Alim. 24V intégrée          | Variable (phase cut) | Variateur à pied |
| Integrated LED                          | 1540 lm | 2700°K | 19W | Int. power supply 24V incl. | Dimmable (phase cut) | Foot op. dimmer  |
| <b>Lampadaire – Floor lamp SOLO 176</b> |         |        |     |                             |                      |                  |
| LED intégrée                            | 1150 lm | 2700°K | 17W | Alim. 24V intégrée          | Variable (phase cut) | Variateur à pied |
| Integrated LED                          | 1150 lm | 2700°K | 17W | Int. power supply 24V incl. | Dimmable (phase cut) | Foot op. dimmer  |

## Designer

Pauline Deltour

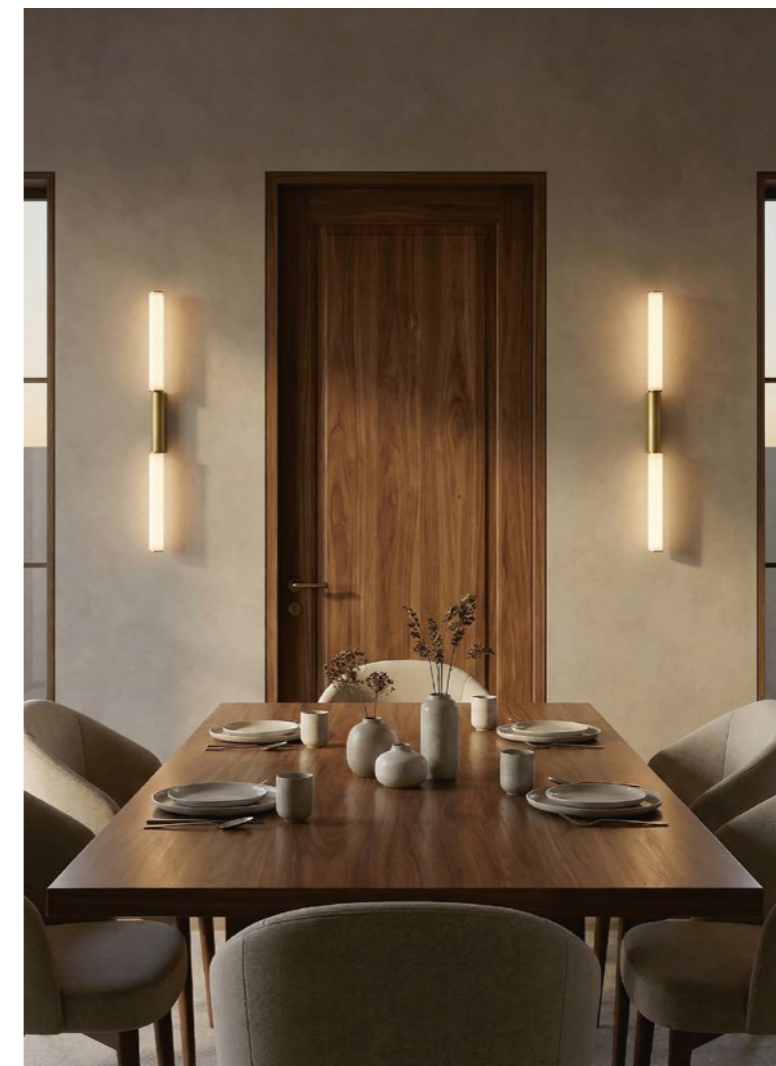

Signal double 720 SB

Signal V 540

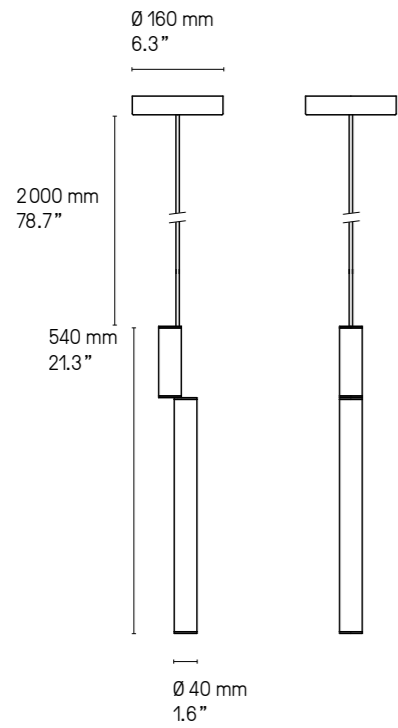

Signal V 540 + V440 SB

Signal V 440

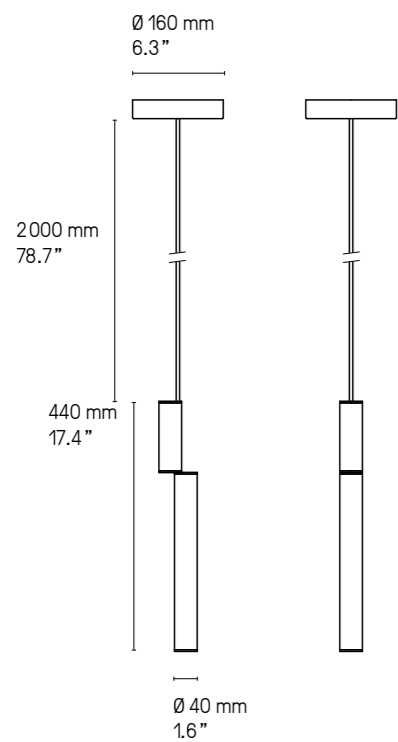

Signal V 340

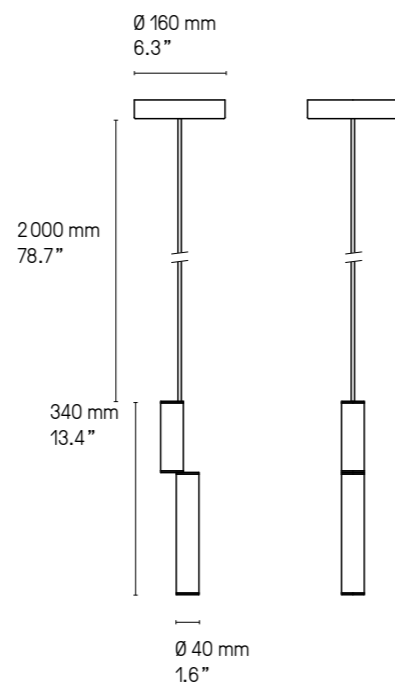

Signal H 970

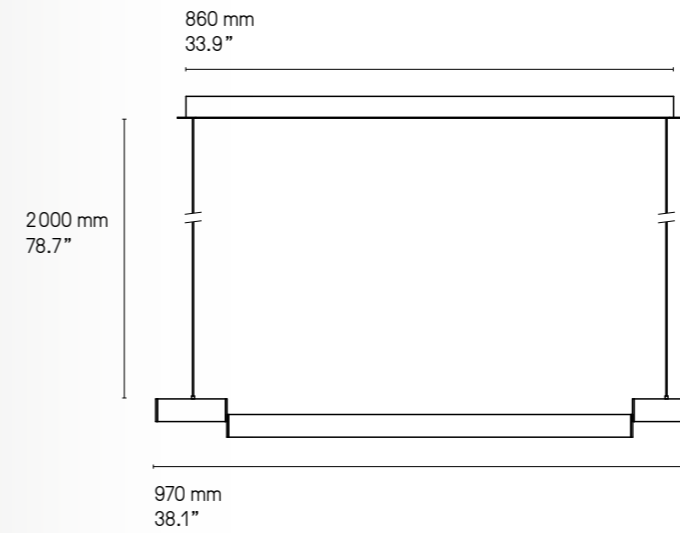

Signal H 770

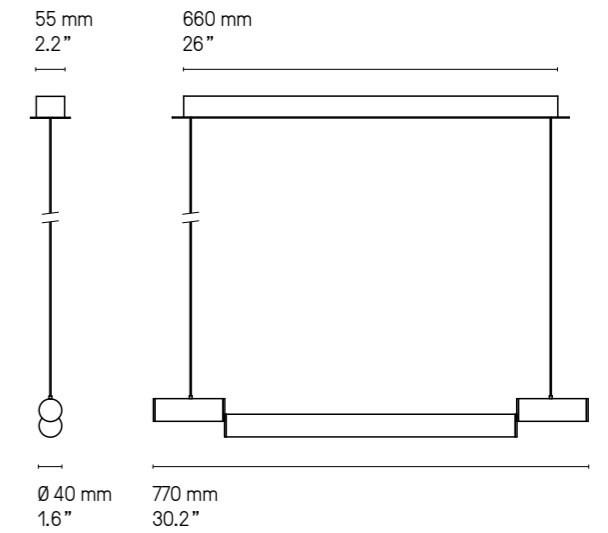

US Version  
fitted plate to cover  
outlet power box

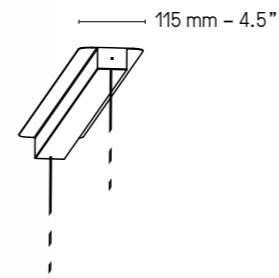

La longueur standard des câbles est de 2 m  
mais elle peut être diminuée à l'installation.  
Autres longueurs sur demande.  
The standard height of the cables is 2 m (78.7")  
but can be adjusted to less during installation  
Custom heights available upon request.



Signal H 770 SB



Appliques – Wall lights

Signal double 920

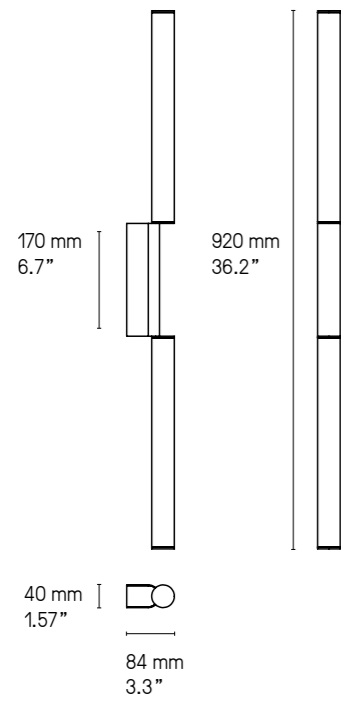

Signal double 720

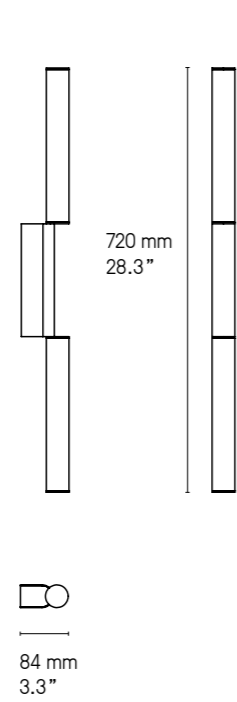

Signal double 520

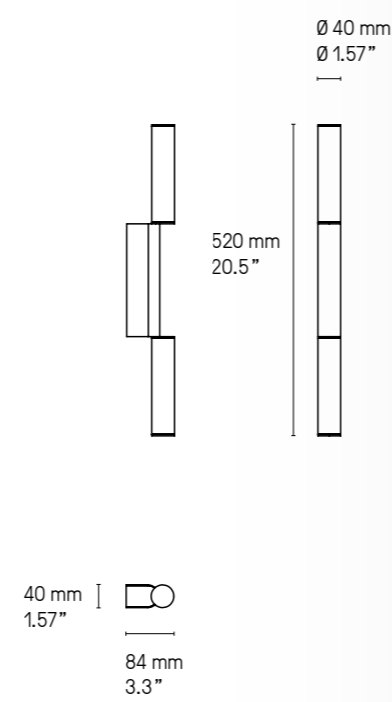

Signal simple 545

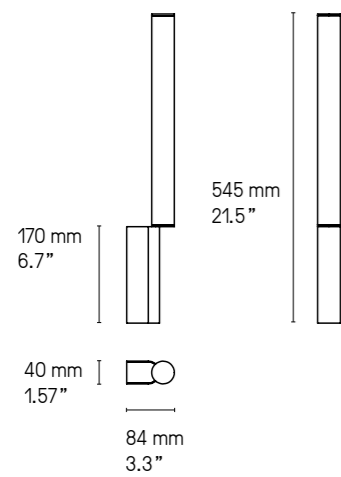

Signal simple 445

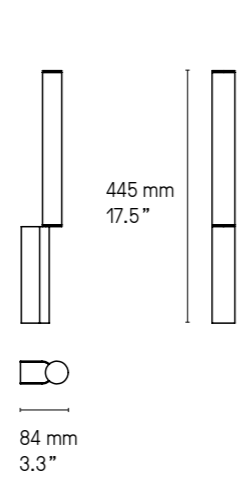

Signal simple 345

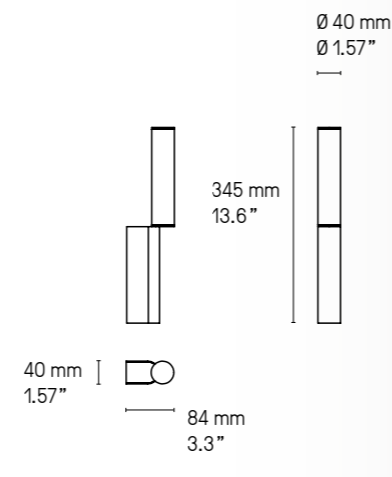

UL Version  
fitted plate to cover outlet power box

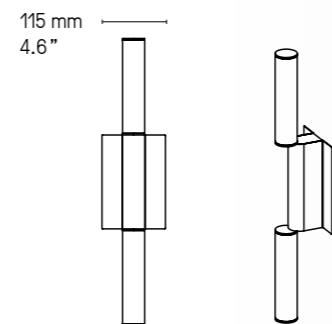

Signal peut être installée horizontalement ou verticalement.  
Signal can be placed both horizontally or vertically on the wall.

Retrouvez les variantes salle de bain (IP44) de ces modèles p.275  
You will find the bathroom variants (IP44) of these designs p.275

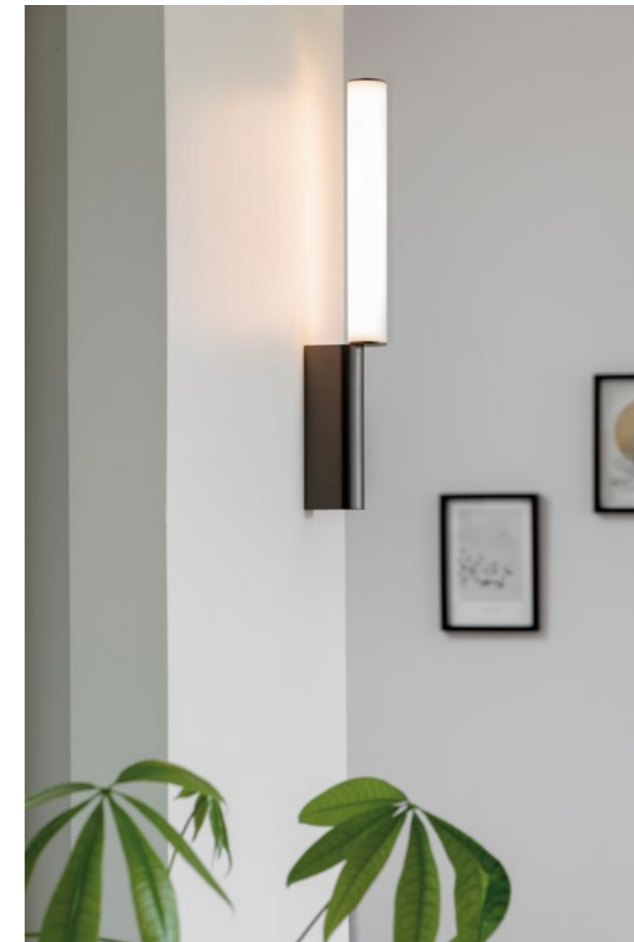

Signal Simple 445 SG

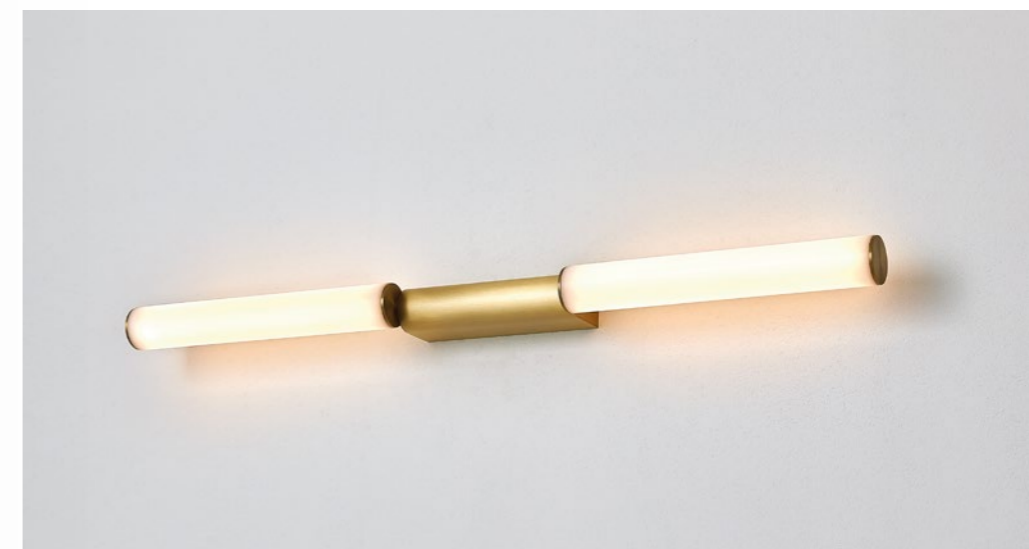

Signal Double 720 SB

Signal Duo

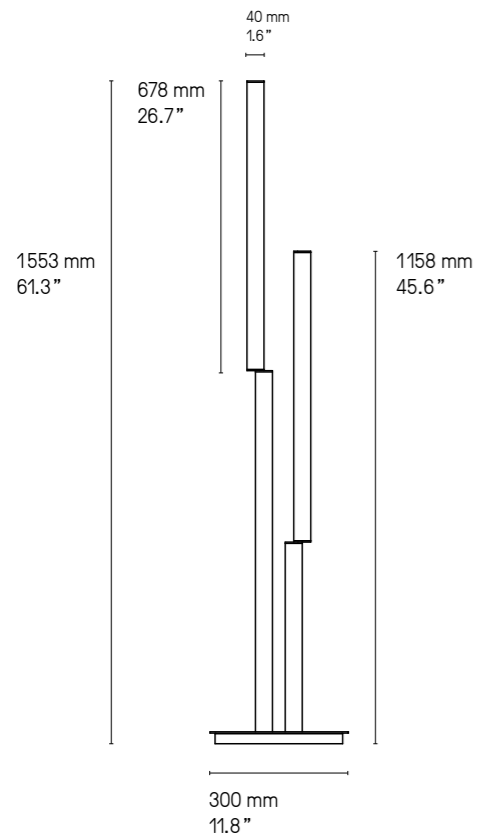

Signal Duo SB

Signal Solo 176

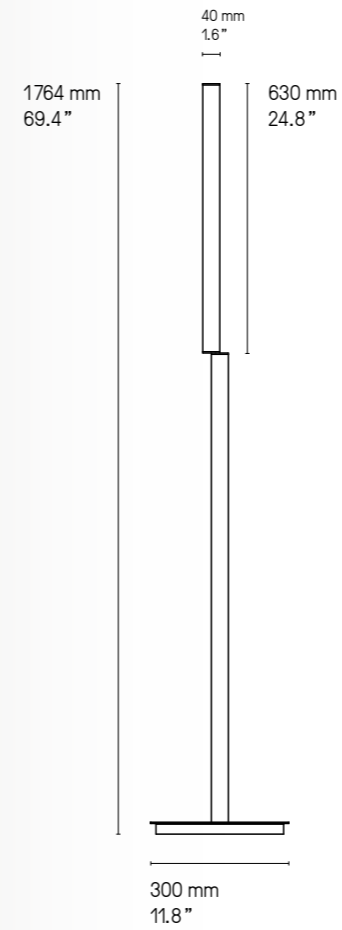

Signal Solo 176 SN

Signal Solo 115

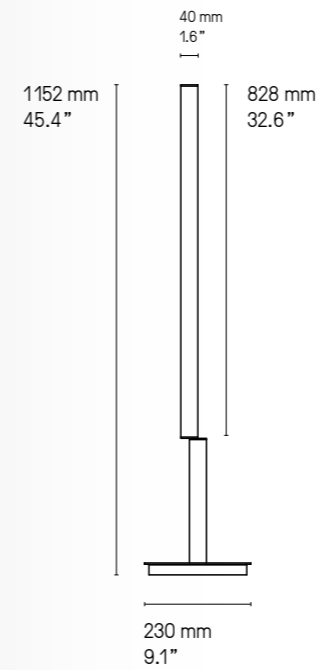

Signal Solo 115 SG



## SOLITAIRE

Ce lampadaire trépied, rehaussé d'un abat-jour à facettes, courtise le bicolore. Personnalisable à souhait, cette pièce unique s'approprie avec élégance vos choix de finitions.



This three-legged floor lamp, enhanced by a faceted lampshade, is even more flattering in a two-tone finish. This unique piece, which can be customized, elegantly blends together with your choice of finishes.

**Finitions** ① + ②  
**Finishes**

Détails page 285

|                                    |   |                                     |                                     |                       |
|------------------------------------|---|-------------------------------------|-------------------------------------|-----------------------|
| ● Laiton satiné<br>SB Satin brass  | ● Graphite satiné<br>SG Satin graphite  | ● Nickel satiné<br>SN Satin nickel  | ● Cuivre satiné<br>SC Satin copper  | ● Bronze<br>BZ Bronze |
| ● Laiton poli<br>PB Polished brass | ● Graphite poli<br>PG Polished graphite | ● Nickel poli<br>PN Polished nickel | ● Cuivre poli<br>PC Polished copper |                       |

**Abat-jour**  
**Lampshade**

|                                    |                                      |
|------------------------------------|--------------------------------------|
| ■ Chinette noire<br>Black chinette | □ Chinette blanche<br>White chinette |
|------------------------------------|--------------------------------------|

**Matériaux**  
**Materials**

|                              |                                      |   |
|------------------------------|--------------------------------------|---|
| Laiton massif<br>Solid Brass | Abat-jour tissu<br>Textile lampshade | Câble textile noir (longueur ≈ 1.5 m)<br>Black textile cable (length ≈ 59") |
|------------------------------|--------------------------------------|---|

**Source**  
**Lamping**

|   |  |                        |
|---|--|------------------------|
| 1 x E27 LED 20W max. non fournie<br>1 x E27 LED 20W max. not included | Variateur à pied<br>Foot operated dimmer | Variation*<br>Dimming* |
| 1 x E26 type A 150W. Bulb not included                                | Foot operated switch                     |                        |

**Designer** Émilie Cathelineau

\* Les luminaires variables nécessitent l'utilisation d'ampoules compatibles avec la variation.  
 All dimmable light fixtures require the use of compatible bulbs.

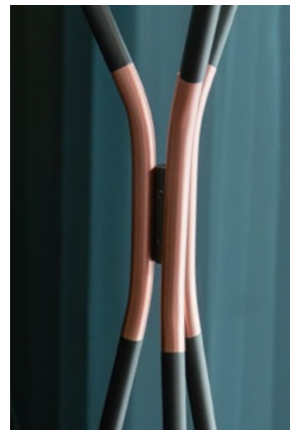

Solitaire XS SB/PB

Solitaire XL SG/SC

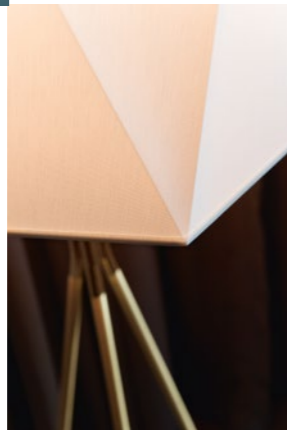

Solitaire XS SB/PB

**Solitaire XL**

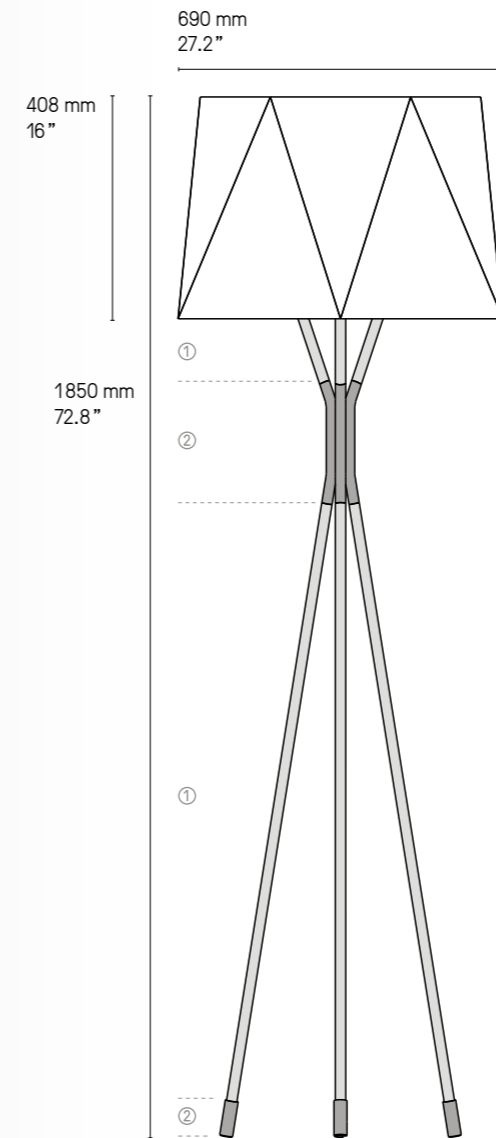
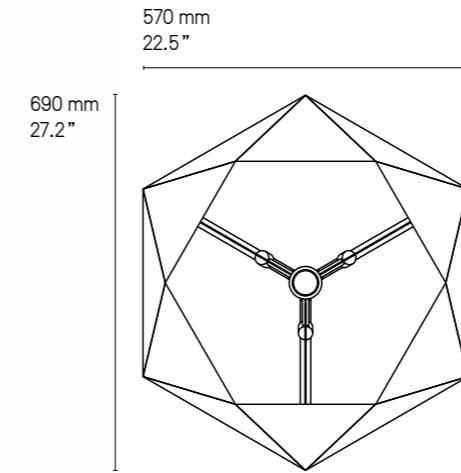

**Solitaire XS**

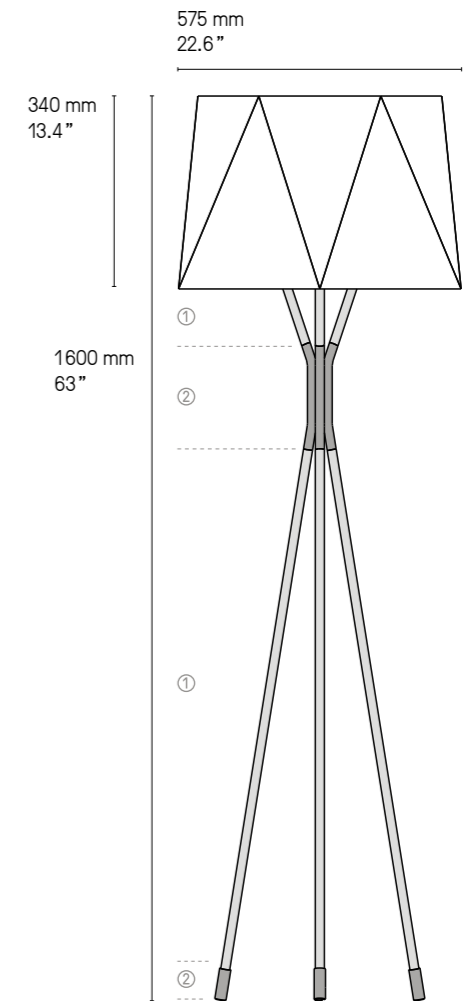
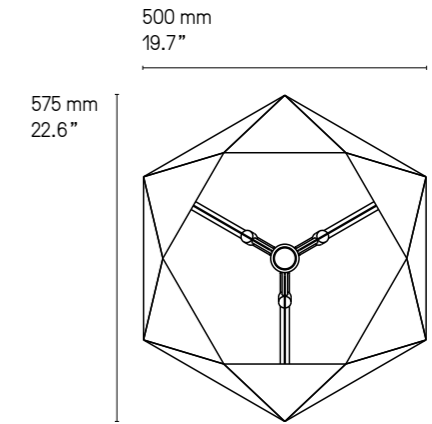

Version LED et DALI sur demande.  
 LED and DALI version upon request.



## STORM

Lumière dirigée pour cette réinterprétation de la lampe tempête. La suspension et la lampe *Storm* affichent des lignes épurées, en toute intimité.



A reinterpretation of a storm made by light. The *Storm* pendant and lamp show off delicate and refined lines.

**Finitions  
Finishes**

Détails page 285

|                                    |   |                                     |                                     |                       |
|------------------------------------|---|-------------------------------------|-------------------------------------|-----------------------|
| ● Laiton satiné<br>SB Satin brass  | ● Graphite satiné<br>SG Satin graphite  | ● Nickel satiné<br>SN Satin nickel  | ● Cuivre satiné<br>SC Satin copper  | ● Bronze<br>BZ Bronze |
| ● Laiton poli<br>PB Polished brass | ● Graphite poli<br>PG Polished graphite | ● Nickel poli<br>PN Polished nickel | ● Cuivre poli<br>PC Polished copper |                       |

**Matériaux  
Materials**

|   |  |   |
|---|--|---|
| <b>Tous – All</b><br>Laiton massif<br>Solid Brass | <b>Tous sauf suspension – All except pendant</b><br>Diffuseur polycarbonate blanc<br>White Polycarbonate diff user | <b>Suspension – Pendant</b><br>Câble métallique gainé<br>Sheathed metal cable |
|---|--|---|

*La longueur standard des câbles est de 2 mètres mais elle peut être diminuée à l'installation.  
The standard height of the cables is 2 meters (78.7") but can be adjusted to less during installation.*

**Source  
Lamping**

Valeurs nominales  
Nominal values

|                                    |         |        |      |  |                        |
|------------------------------------|---------|--------|------|--|------------------------|
| <b>Suspension – Pendant</b>        |         |        |      |  |                        |
| LED intégrée                       | 550 lm  | 2700°K | 8 W  | Alimentation intégrée dans le pavillon | Variable (phase cut)   |
| Integrated LED                     | 550 lm  | 2700°K | 8 W  | Int. power supply included in canopy   | Dimmable (phase cut)   |
| <b>Applique – Wall lamp</b>        |         |        |      |  |                        |
| LED intégrée                       | 480 lm  | 2700°K | 7 W  | Alim. intégrée                         |                        |
| Integrated LED                     | 480 lm  | 2700°K | 7 W  | Internal power supply                  |                        |
| <b>Lampe de table – Table lamp</b> |         |        |      |  |                        |
| LED intégrée                       | 480 lm  | 2700°K | 5 W  | Alim. intégrée sur la prise            | Interrupteur sur câble |
| Integrated LED                     | 480 lm  | 2700°K | 5 W  | Plug-in power supply                   | Cable switch           |
| <b>Lampadaire – Floor lamp</b>     |         |        |      |  |                        |
| LED intégrée                       | 1440 lm | 2700°K | 10 W | Alim. intégrée sur la prise            | Interrupteur à pied    |
| Integrated LED                     | 1440 lm | 2700°K | 10 W | Plug-in power supply                   | Foot operated switch   |

**Designer**

Émilie Cathelineau

**Lampe de table – Table lamp**

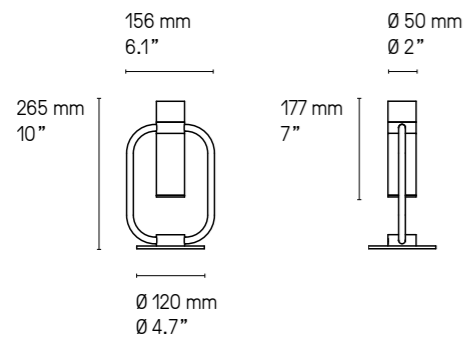

Lampe de table – Table lamp Storm SB

**Applique – Wall light**

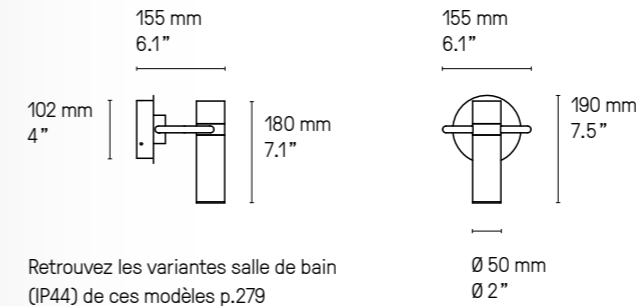

**US Version  
fitted plate to cover  
outlet power box**

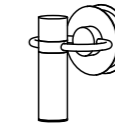

Applique – Wall light Storm SB

Retrouvez les variantes salle de bain (IP44) de ces modèles p.279  
You will find the bathroom variants (IP44) of these designs p.279

**Lampadaire – Floor lamp**

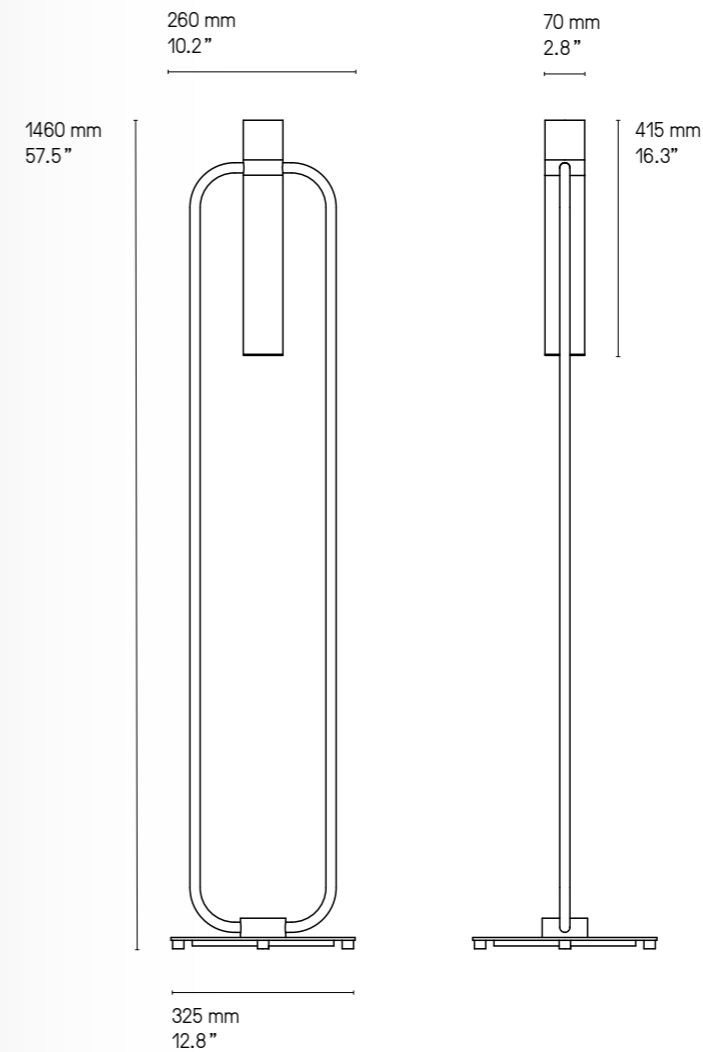

Lampadaire – Floor lamp Storm SB

Suspension – Pendant

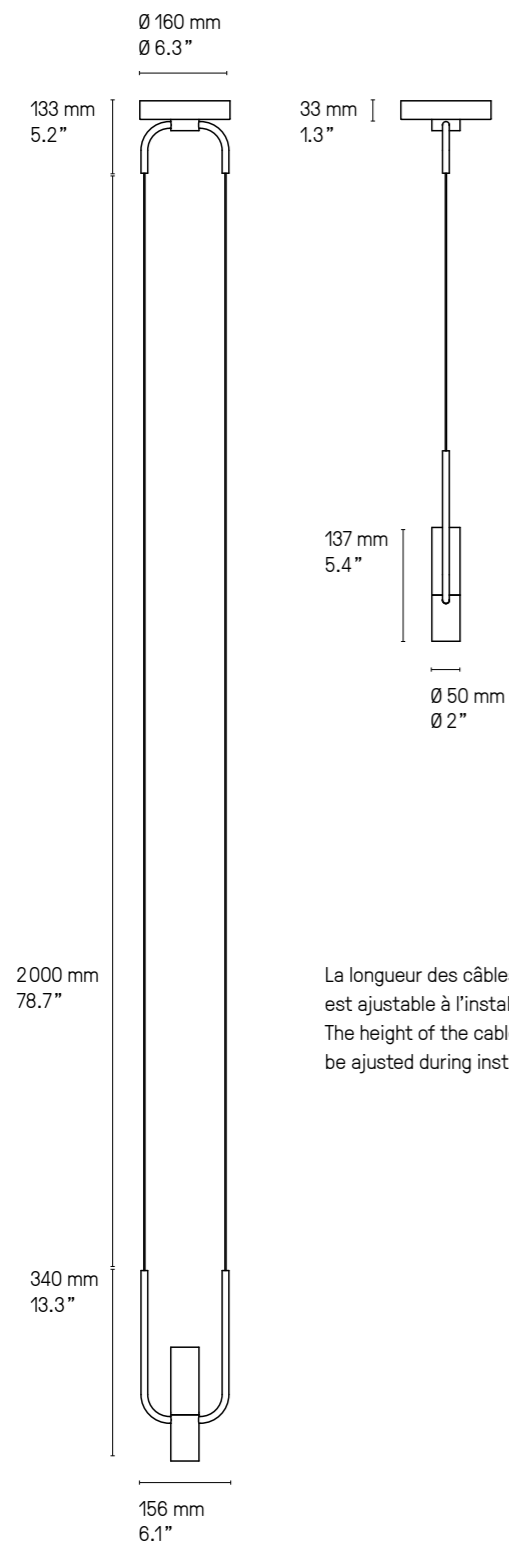

La longueur des câbles est ajustable à l'installation.  
The height of the cables can be adjusted during installation.



Suspension – Pendant Storm SG



Suspension – Pendant Storm SB



Suspension – Pendant Storm SB



## STRATE

Collection de formes reliées par un trait lumineux, *Strate*, véritable sculpture, orne le mur aussi bien à la verticale qu'à l'horizontale. Par ses dimensions généreuses, elle habille l'espace et en devient une pièce maîtresse.



A collection of shapes linked by a luminous line, *Strate*, an authentic sculpture, adorns the wall both vertically and horizontally. With its generous dimensions, it covers the room and becomes a centerpiece.

**Finitions**  
**Finishes**

① + ②

- Laiton satiné  
SB Satin brass
- Graphite satiné  
SG Satin graphite
- Nickel satiné  
SN Satin nickel
- Cuivre satiné  
SC Satin copper
- Bronze  
BZ Bronze

Détails page 285

**Matériaux**  
**Materials**

Laiton massif / Solid Brass  
Diffuseur en polycarbonate / Polycarbonate diffuser

**Source**  
**Lamping**

*Valeurs nominales  
Nominal values*

|                   |          |          |      |                                  |                      |  |
|-------------------|----------|----------|------|----------------------------------|----------------------|--|
| <b>Strate 150</b> |          |          |      |                                  |                      |  |
| LED intégrée      | 6 100 lm | 2 700° K | 80 W | Alim. électronique 24 V intégrée | Variable (phase cut) |  |
| Integrated LED    | 6 100 lm | 2 700° K | 80 W | Integrated 24 V power supply     | Dimmable (phase cut) |  |
| <b>Strate 100</b> |          |          |      |                                  |                      |  |
| LED intégrée      | 3 800 lm | 2 700° K | 48 W | Alim. électronique 24 V intégrée | Variable (phase cut) |  |
| Integrated LED    | 3 800 lm | 2 700° K | 48 W | Integrated 24 V power supply     | Dimmable (phase cut) |  |

**Designer**

Émilie Cathelineau



Strate Score 150 SG/SB

**US Version**  
**fitted plate to cover outlet power box**

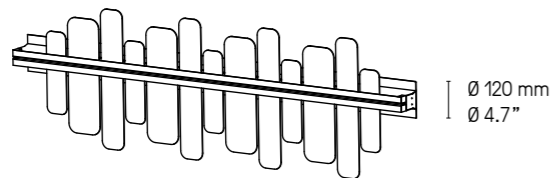

Chaque modèle peut s'installer à la verticale ou à l'horizontale.  
Each model can be installed vertically or horizontally.

**Strate Score 150**

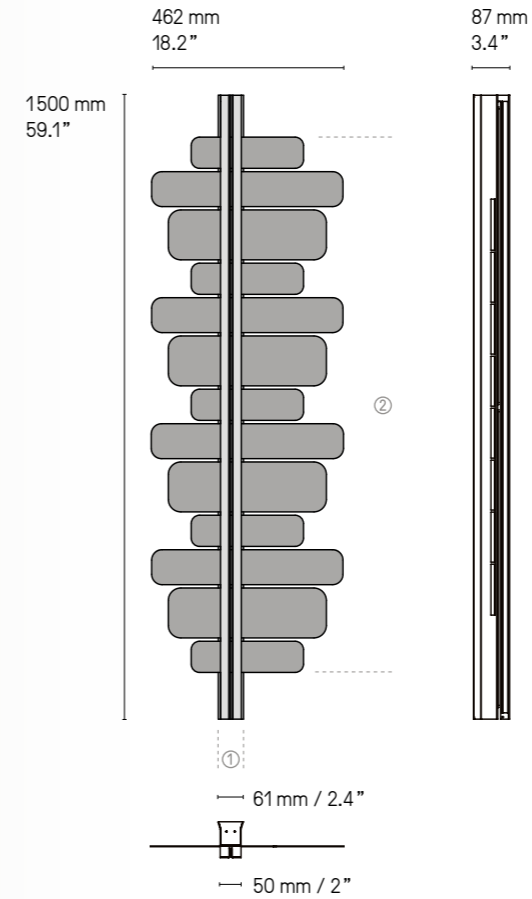

Strate Score 150 SG/SB

**Strate Score 100**

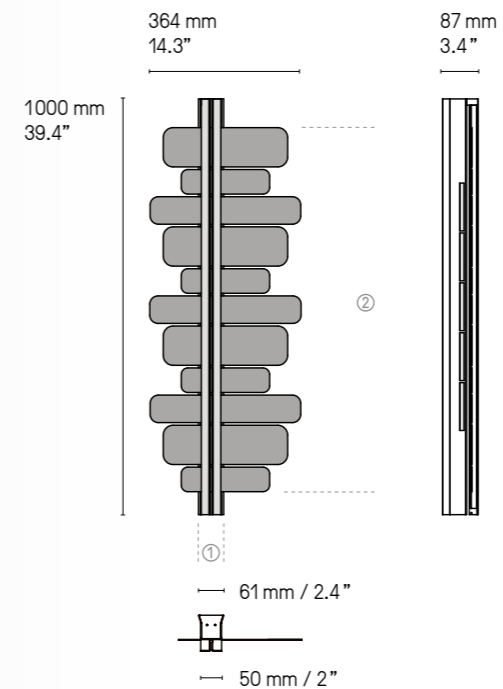

Strate Score 100 SG/SN



Strate Score 150 SG/SB



Strate Stone 150 SG/SB

**Strate Stone 150**

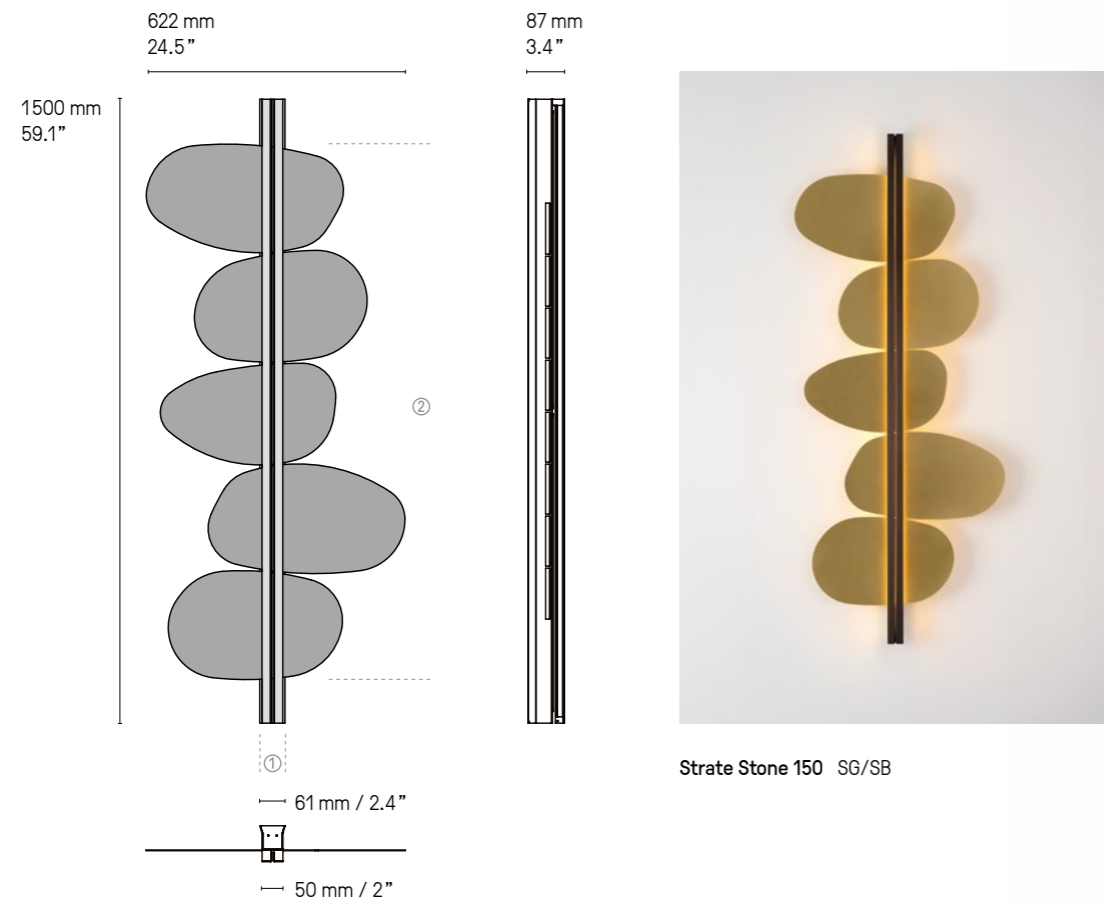

**Strate Spi 150**

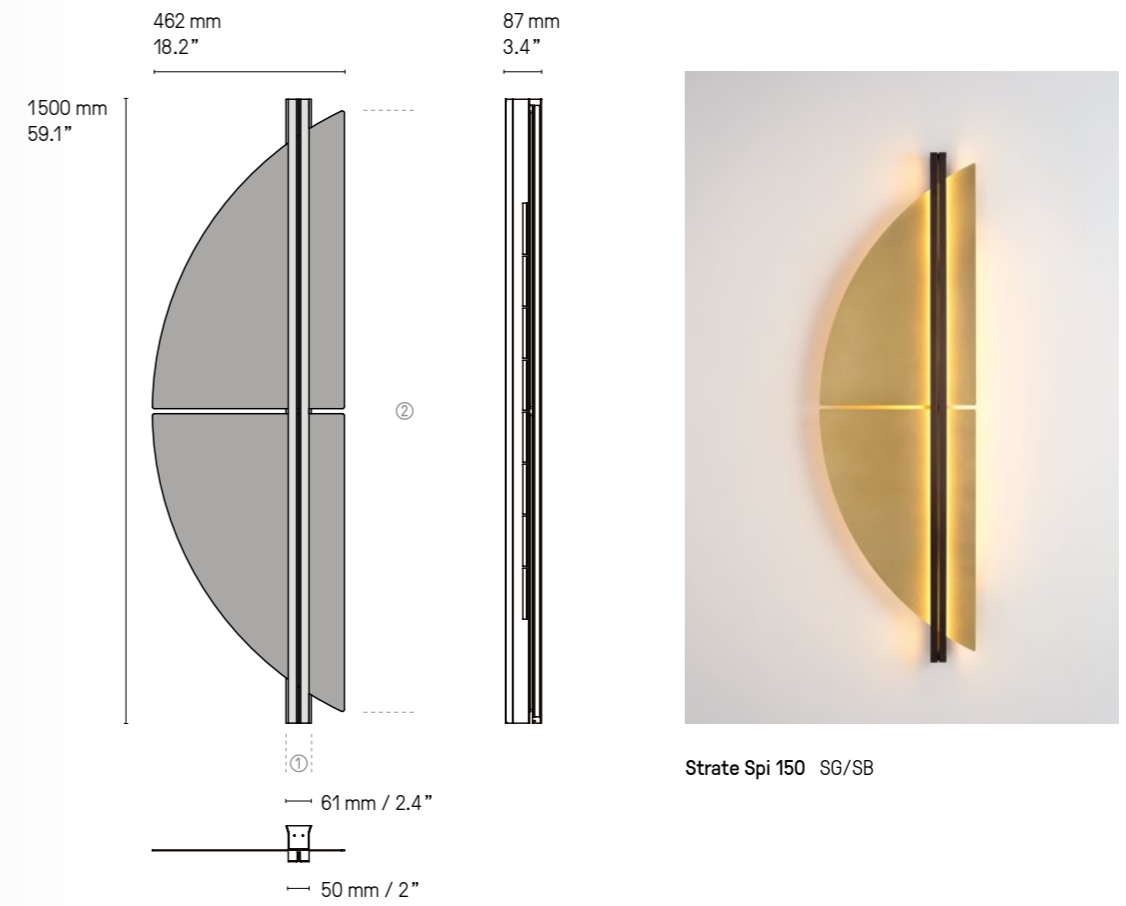

**Strate Stone 100**

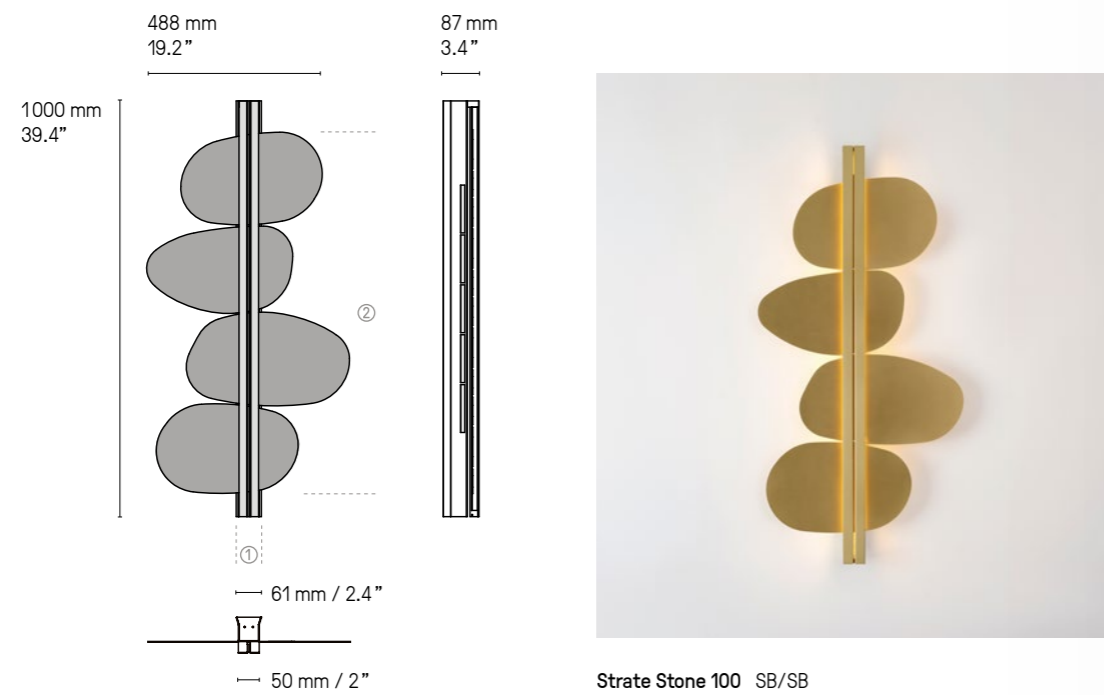

**Strate Spi 100**

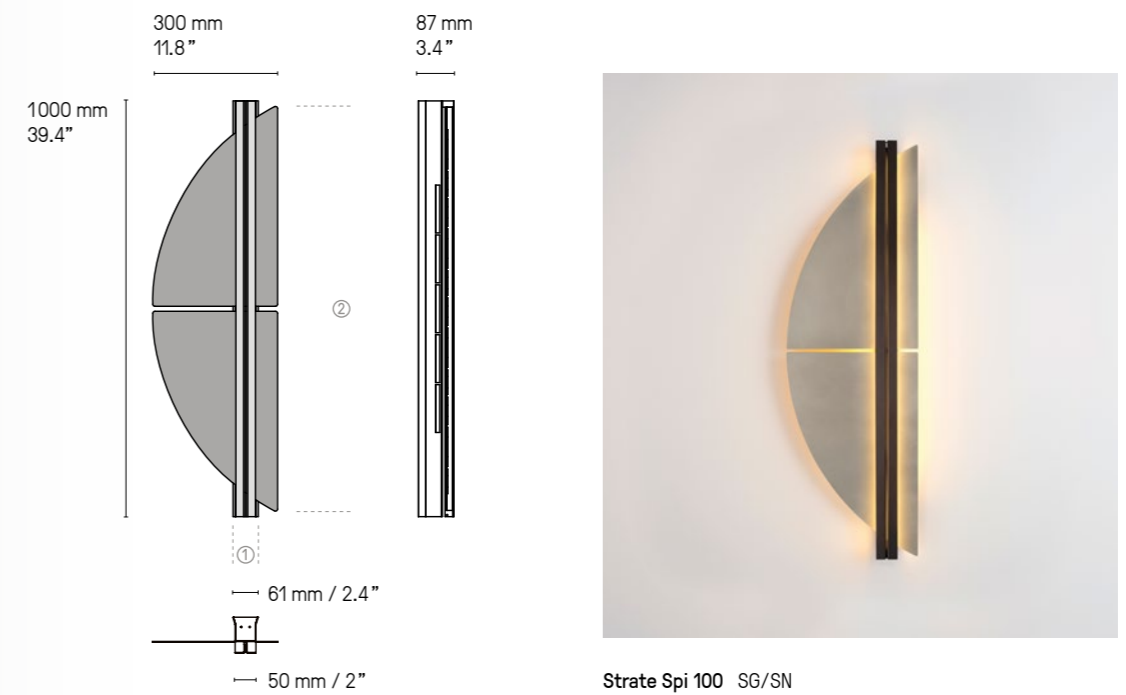



**Strate Moon 150**

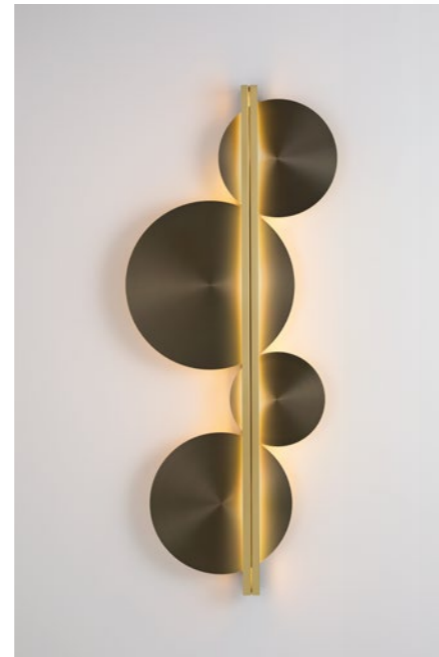
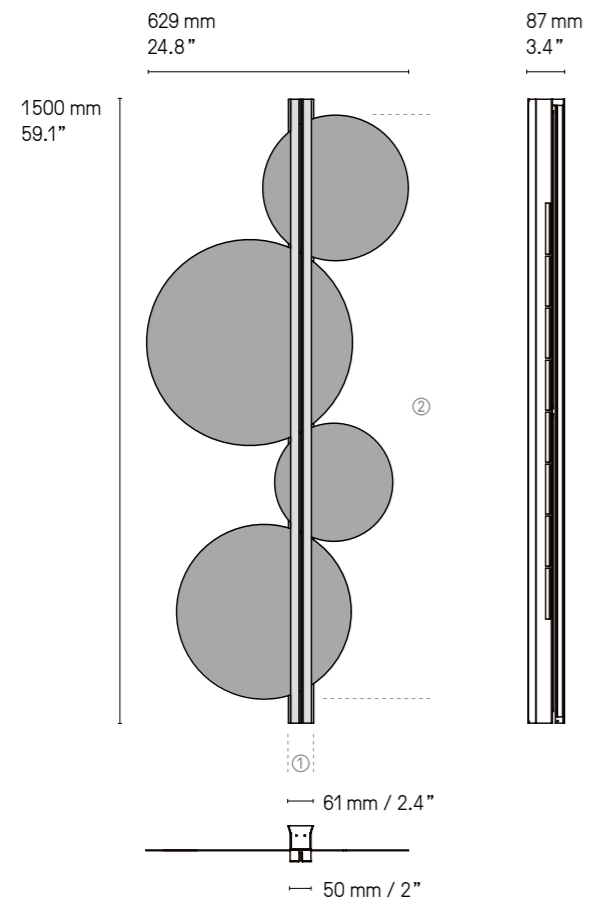

Strate Moon 150 SB/SG

**Strate Moon 100**

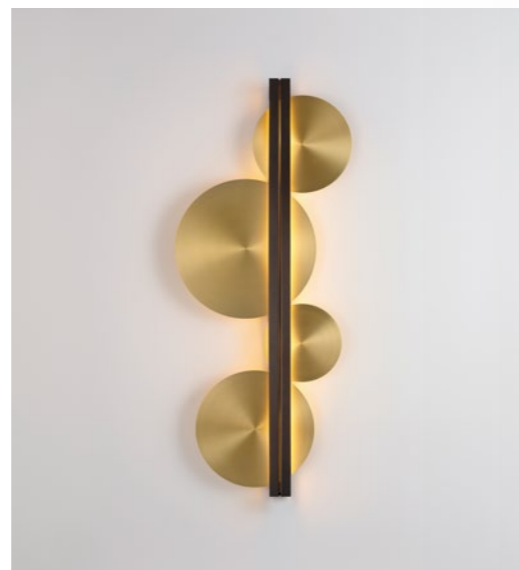
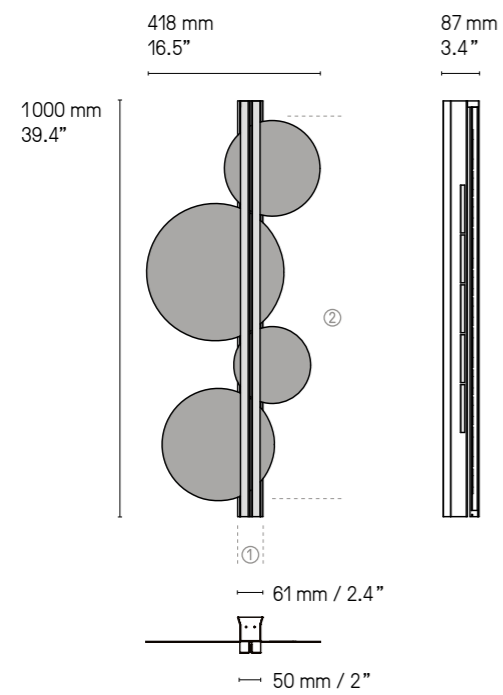

Strate Moon 100 SG/SB



Strate Moon 150 SG/SB



## TÉTRA

Seul ou en composition, le module triangulaire *Tétra* dessine par la lumière vos inspirations. Un objet sobre se multipliant à l'infini.



By itself or as an arrangement, the triangular module *TétrA* can shape your own creation with light. A simple object that can be multiplied endlessly.

**Finitions**  
**Finishes**

Détails page 285

|                                    |   |                                     |                                     |                       |
|------------------------------------|---|-------------------------------------|-------------------------------------|-----------------------|
| ● Laiton satiné<br>SB Satin brass  | ● Graphite satiné<br>SG Satin graphite  | ● Nickel satiné<br>SN Satin nickel  | ● Cuivre satiné<br>SC Satin copper  | ● Bronze<br>BZ Bronze |
| ● Laiton poli<br>PB Polished brass | ● Graphite poli<br>PG Polished graphite | ● Nickel poli<br>PN Polished nickel | ● Cuivre poli<br>PC Polished copper |                       |

**Matériaux**  
**Materials**

|                              |   |
|------------------------------|---|
| Laiton massif<br>Solid Brass | Diffuseur en polycarbonate<br>Polycarbonate diffuseur |
|------------------------------|---|

**Description**  
**Features**

Lorsqu'ils sont positionnés côte à côte, les luminaires *Tétra* peuvent être interconnectés grâce à un câble circulant entre le mur et l'arrière du luminaire. Ce montage ne nécessite qu'une seule sortie électrique. Veuillez noter que le système d'interconnection n'est pas certifié UL.

Positioned side by side, *Tétra* lights can be interconnected with a cable that runs between the wall and the back of the lights. This arrangement requires only one electrical outlet. Please be aware that this interconnected system is not up to code in the US and is not UL certified.

**Source**  
**Lamping**

Valeurs nominales  
Nominal values

|  |        |        |     |                         |                       |
|--|--------|--------|-----|-------------------------|-----------------------|
| LED intégrée   | 700 lm | 2700°K | 8 W | Alim. électr. intégrée  | Variation (phase cut) |
| Integrated LED   | 700 lm | 2700°K | 8 W | Integrated power supply | Dimmable (phase cut)  |
|  Integrated LED | 700 lm | 2700°K | 8 W | Integrated power supply | Not dimmable          |

**Designer**

Émilie Cathelineau



Tétra SB

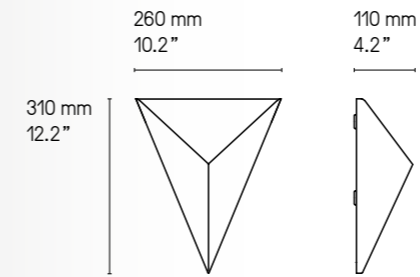

Tétra SN



Tétra SG

**Exemples de compositions**  
**Examples of arrangements**

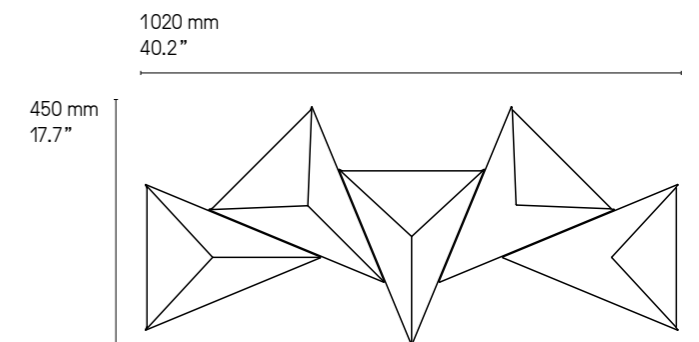
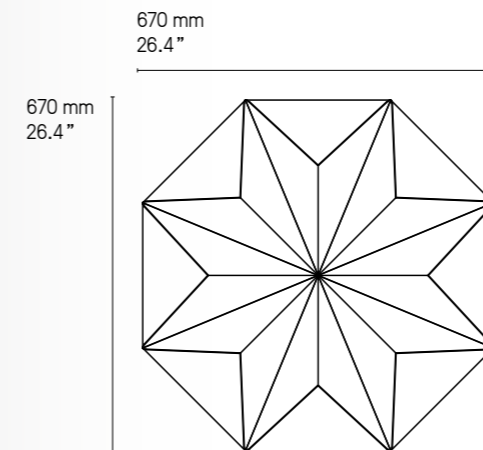
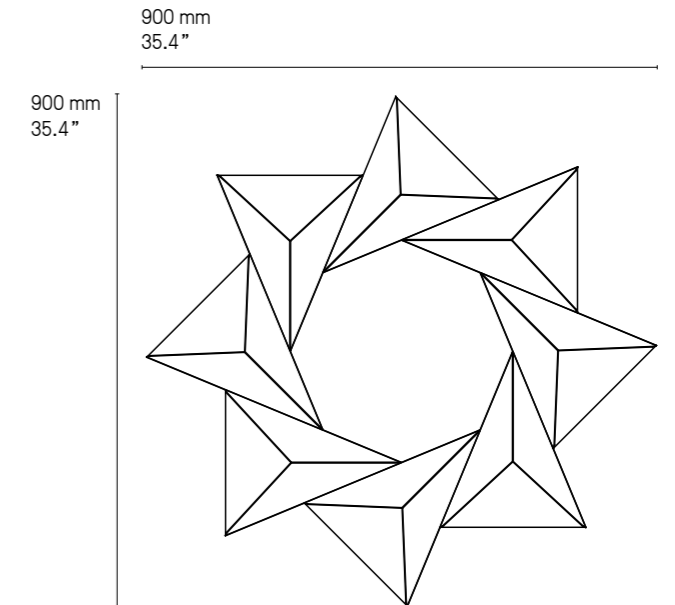
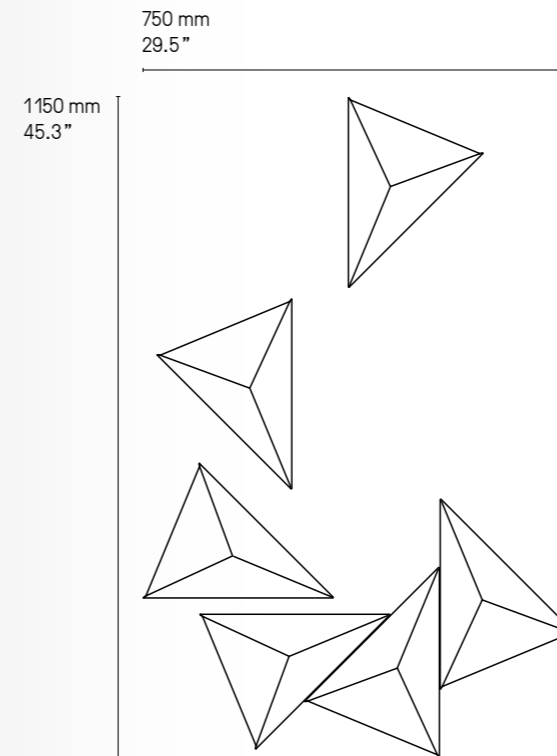



## UPPER

Lampadaire unique aux dimensions généreuses, *Upper* investit l'espace comme un objet à la fois utile et précieux. Inspiré des gratte-ciel de Manhattan, ses lignes invitent le regard à monter vers le ciel.



A unique floor lamp with large dimensions, *Upper* uses space as a valuable and useful object. Tall with straight brass tubes, this light is inspired by Manhattan's skyscrapers.

**Finitions  
Finishes**

Détails page 285

|                                    |   |                                     |                                     |                       |
|------------------------------------|---|-------------------------------------|-------------------------------------|-----------------------|
| ● Laiton satiné<br>SB Satin brass  | ● Graphite satiné<br>SG Satin graphite  | ● Nickel satiné<br>SN Satin nickel  | ● Cuivre satiné<br>SC Satin copper  | ● Bronze<br>BZ Bronze |
| ● Laiton poli<br>PB Polished brass | ● Graphite poli<br>PG Polished graphite | ● Nickel poli<br>PN Polished nickel | ● Cuivre poli<br>PC Polished copper |                       |

**Abat-jour  
Lampshade**

|                   |                   |
|-------------------|-------------------|
| □ Drop Paper® 100 | ■ Drop Paper® 101 |
|-------------------|-------------------|

**Matériaux  
Materials**

|                              |  |   |
|------------------------------|--|---|
| Laiton massif<br>Solid Brass | Abat-jour Drop Paper® M1<br>Lampshade Drop Paper® M1 | Câble textile noir (longueur ≈ 2 m)<br>Black textile cable (length ≈ 78.7") |
|------------------------------|--|---|

**Source  
Lamping**

|   |  |                        |
|---|--|------------------------|
| 3 x E27 LED 15 W max. non fournie<br>3 x E27 LED 15 W max. not included | Variateur à pied<br>Foot operated dimmer | Variation*<br>Dimming* |
| 3 x E26 type A 60 W. Bulb not included                                  | Foot operated switch                     |                        |

**Designer**

Hervé Langlais

\* Les luminaires variables nécessitent l'utilisation d'ampoules compatibles avec la variation.  
All dimmable light fixtures require the use of compatible bulbs.

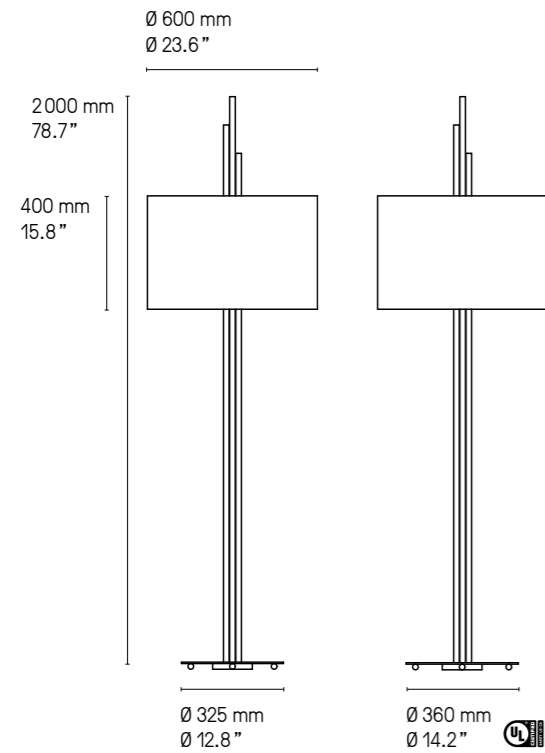

Upper SB

Version LED et DALI sur demande.  
LED and DALI version upon request.



Upper SG



CVL

## APPLIQUES SALLE DE BAIN BATHROOM WALL LIGHTS

Élégance des formes, aux accents minimalistes et aux finitions soignées. Retrouvez l'esprit CVL dans une collection d'appliques esthétiques et fonctionnelles, spécifiquement conçues pour la salle de bain.



Elegant shapes, minimalist accents and immaculate finishes. Find the CVL spirit in a collection of aesthetic and functional wall lights, specifically designed for bathrooms.



# IP BACKSTAGE



## Finitions Finishes

Détails page 285

|                                    |   |                                     |                                     |                       |
|------------------------------------|---|-------------------------------------|-------------------------------------|-----------------------|
| ● Laiton satiné<br>SB Satin brass  | ● Graphite satiné<br>SG Satin graphite  | ● Nickel satiné<br>SN Satin nickel  | ● Cuivre satiné<br>SC Satin copper  | ● Bronze<br>BZ Bronze |
| ● Laiton poli<br>PB Polished brass | ● Graphite poli<br>PG Polished graphite | ● Nickel poli<br>PN Polished nickel | ● Cuivre poli<br>PC Polished copper |                       |

## Matériaux Materials

|                              |  |
|------------------------------|--|
| Laiton massif<br>Solid Brass | Verre triplex opale soufflé bouche<br>Opal triplex mouth-blown glass |
|------------------------------|--|

## Source Lamping

Valeurs nominales  
Nominal values

|                              |         |         |    |                             |                           |
|------------------------------|---------|---------|----|-----------------------------|---------------------------|
| <b>IP Backstage 4</b>        |         |         |    |                             |                           |
| LED intégrée                 | 520 lm  | 3 000°K | 5W | Alimentation 24V intégrée   | Non variable en standard  |
| Integrated LED               | 520 lm  | 3 000°K | 5W | Int. power supply 24V incl. | Standard version not dim. |
| <b>IP Backstage 6</b>        |         |         |    |                             |                           |
| LED intégrée                 | 780 lm  | 3 000°K | 7W | Alimentation 24V intégrée   | Non variable en standard  |
| Integrated LED               | 780 lm  | 3 000°K | 7W | Int. power supply 24V incl. | Standard version not dim. |
| <b>IP Backstage 8</b>        |         |         |    |                             |                           |
| LED intégrée                 | 1040 lm | 3 000°K | 9W | Alimentation 24V intégrée   | Non variable en standard  |
| Integrated LED               | 1040 lm | 3 000°K | 9W | Int. power supply 24V incl. | Standard version not dim. |
| <b>IP Backstage Corner 4</b> |         |         |    |                             |                           |
| LED intégrée                 | 520 lm  | 3 000°K | 5W | Alimentation 24V intégrée   | Non variable en standard  |
| Integrated LED               | 520 lm  | 3 000°K | 5W | Int. power supply 24V incl. | Standard version not dim. |
| <b>IP Backstage Corner 6</b> |         |         |    |                             |                           |
| LED intégrée                 | 780 lm  | 3 000°K | 7W | Alimentation 24V intégrée   | Non variable en standard  |
| Integrated LED               | 780 lm  | 3 000°K | 7W | Int. power supply 24V incl. | Standard version not dim. |
| <b>IP Backstage Corner 8</b> |         |         |    |                             |                           |
| LED intégrée                 | 1040 lm | 3 000°K | 9W | Alimentation 24V intégrée   | Non variable en standard  |
| Integrated LED               | 1040 lm | 3 000°K | 9W | Int. power supply 24V incl. | Standard version not dim. |

## Norme Standard

|      |           |
|------|-----------|
| IP44 | Classe II |
| IP44 | Class II  |

## Designer

Émilie Cathelineau

**IP Backstage Linear L8**

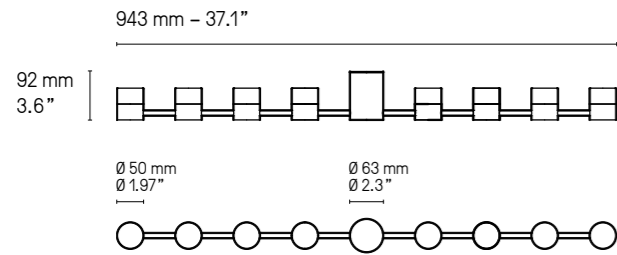

**IP Backstage Corner C8**

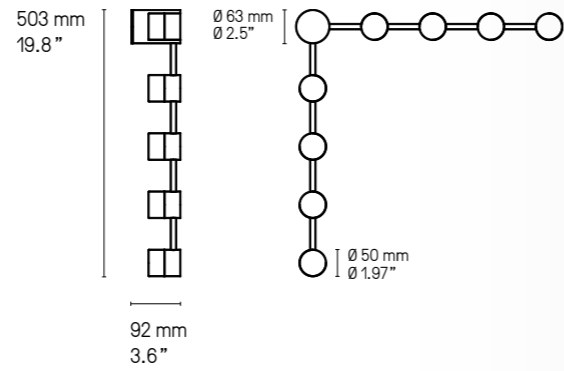

**IP Backstage Linear L6**

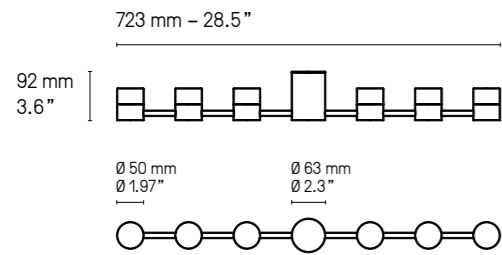

**IP Backstage Corner C6**

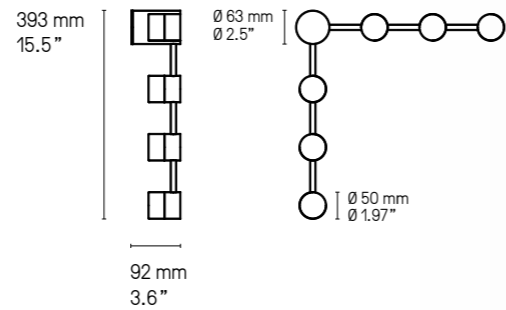

**IP Backstage Linear L4**

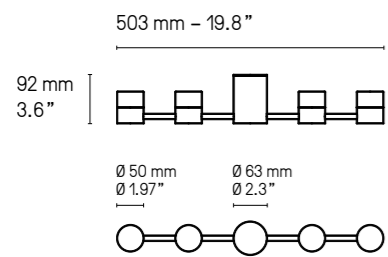

**IP Backstage Corner C4**

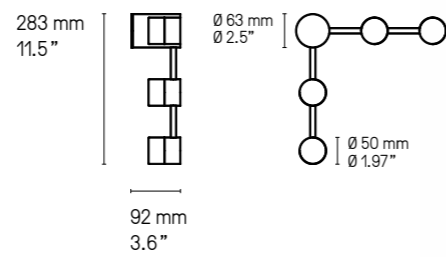

**US Version  
fitted plate to cover outlet power box**

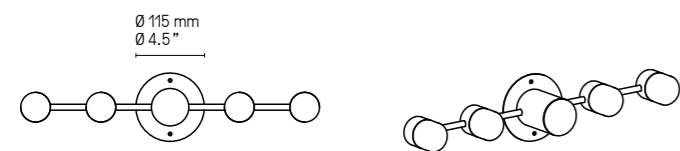



IP Backstage Corner C8 SG



IP Backstage Linear L6 PN



IP Backstage Linear L4 SB



IP Backstage Linear L6 SG



IP Backstage Corner C8 PB



# IP CALÉ(E)



## Finitions Finishes ①+②

Détails page 285

|   |  |  |  |                              |
|---|--|--|--|------------------------------|
| ● Laiton satiné<br><b>SB</b> Satin brass  | ● Graphite satiné<br><b>SG</b> Satin graphite  | ● Nickel satiné<br><b>SN</b> Satin nickel  | ● Cuivre satiné<br><b>SC</b> Satin copper  | ● Bronze<br><b>BZ</b> Bronze |
| ● Laiton poli<br><b>PB</b> Polished brass | ● Graphite poli<br><b>PG</b> Polished graphite | ● Nickel poli<br><b>PN</b> Polished nickel | ● Cuivre poli<br><b>PC</b> Polished copper |                              |

## Matériaux Materials

|                              |   |
|------------------------------|---|
| Laiton massif<br>Solid Brass | Diffuseur polycarbonate satiné<br>Satin Polycarbonate diff user |
|------------------------------|---|

## Source Lamping

Valeurs nominales  
Nominal values

|                                |        |         |     |  |  |
|--------------------------------|--------|---------|-----|--|--|
| LED intégrée<br>Integrated LED | 880 lm | 3 000°K | 10W | Alimentation 24V intégrée<br>Int. power supply 24V incl. | Variable (phase cut)<br>Dimmable (phase cut) |
|--------------------------------|--------|---------|-----|--|--|

## Norme Standard

|      |           |
|------|-----------|
| IP44 | Classe II |
| IP44 | Class II  |

## Designer

POOL

### VH

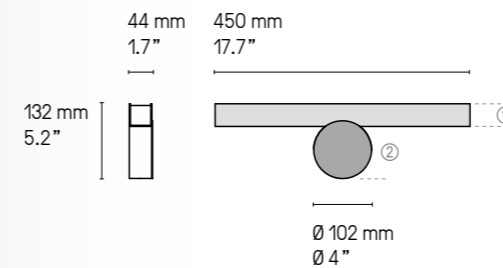

### VV

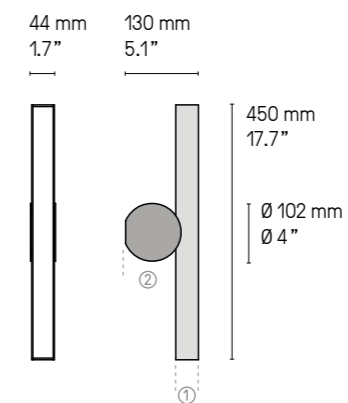

### VF

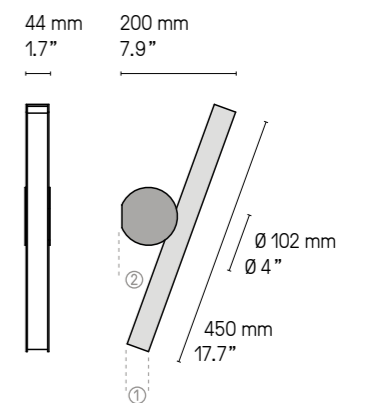

Les appliques Calé(e)s ne sont pas réglables. Ce sont 3 modèles différents.  
Calé(e) wall lights are not mobile. These are 3 different fixed models.



# IP CORNET



## Finitions Finishes

Détails page 285

|   |  |  |  |                              |
|---|--|--|--|------------------------------|
| ● Laiton satiné<br><b>SB</b> Satin brass  | ● Graphite satiné<br><b>SG</b> Satin graphite  | ● Nickel satiné<br><b>SN</b> Satin nickel  | ● Cuivre satiné<br><b>SC</b> Satin copper  | ● Bronze<br><b>BZ</b> Bronze |
| ● Laiton poli<br><b>PB</b> Polished brass | ● Graphite poli<br><b>PG</b> Polished graphite | ● Nickel poli<br><b>PN</b> Polished nickel | ● Cuivre poli<br><b>PC</b> Polished copper |                              |

## Matériaux Materials

|                              |  |
|------------------------------|--|
| Laiton massif<br>Solid Brass | Verre triplex opale soufflé bouche<br>Opal triplex mouth-blown glass |
|------------------------------|--|

## Source Lamping

|   |                        |
|---|------------------------|
| G9 LED 5W max. non fournie<br>G9 LED 5W max. not included | Variable*<br>Dimmable* |
|---|------------------------|

## Norme Standard

|      |           |
|------|-----------|
| IP24 | Classe II |
| IP24 | Class II  |

## Designer

POOL

\* Les luminaires variables nécessitent l'utilisation d'ampoules compatibles avec la variation.  
All dimmable light fixtures require the use of compatible bulbs.

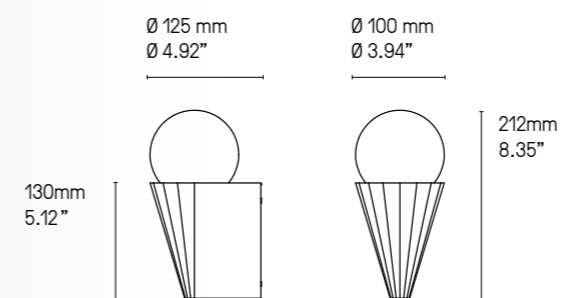

IP Cornet PN



# IP GAMMA



## Finitions Finishes

Détails page 285

|   |  |  |  |                              |
|---|--|--|--|------------------------------|
| ● Laiton satiné<br><b>SB</b> Satin brass  | ● Graphite satiné<br><b>SG</b> Satin graphite  | ● Nickel satiné<br><b>SN</b> Satin nickel  | ● Cuivre satiné<br><b>SC</b> Satin copper  | ● Bronze<br><b>BZ</b> Bronze |
| ● Laiton poli<br><b>PB</b> Polished brass | ● Graphite poli<br><b>PG</b> Polished graphite | ● Nickel poli<br><b>PN</b> Polished nickel | ● Cuivre poli<br><b>PC</b> Polished copper |                              |

## Matériaux Materials

|                              |   |
|------------------------------|---|
| Laiton massif<br>Solid Brass | Diffuseur polycarbonate blanc<br>White Polycarbonate diffuser |
|------------------------------|---|

## Source Lamping

Valeurs nominales  
Nominal values

|                                |                  |                        |  |   |
|--------------------------------|------------------|------------------------|--|---|
| LED intégrée<br>Integrated LED | 500 lm<br>500 lm | 3000°K 8W<br>3000°K 8W | Alimentation 24V intégrée<br>Int. power supply 24V incl. | Non variable en standard<br>Standard version not dim. |
|--------------------------------|------------------|------------------------|--|---|

## Norme Standard

|      |           |
|------|-----------|
| IP44 | Classe II |
| IP44 | Class II  |

## Designer

Sylvain Willenz

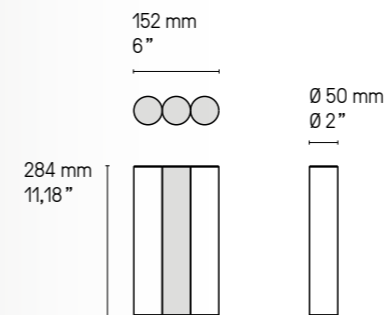

IP Gamma SB

IP Gamma SG

IP Gamma SN

IP Gamma SC



# IP JANED



## Finitions Finishes ①+②

Détails page 285

|   |  |  |  |                              |
|---|--|--|--|------------------------------|
| ● Laiton satiné<br><b>SB</b> Satin brass  | ● Graphite satiné<br><b>SG</b> Satin graphite  | ● Nickel satiné<br><b>SN</b> Satin nickel  | ● Cuivre satiné<br><b>SC</b> Satin copper  | ● Bronze<br><b>BZ</b> Bronze |
| ● Laiton poli<br><b>PB</b> Polished brass | ● Graphite poli<br><b>PG</b> Polished graphite | ● Nickel poli<br><b>PN</b> Polished nickel | ● Cuivre poli<br><b>PC</b> Polished copper |                              |

## Matériaux Materials

|                              |   |
|------------------------------|---|
| Laiton massif<br>Solid Brass | Verre triplex opale<br>Opal triplex glass |
|------------------------------|---|

## Source Lamping

|   |                        |
|---|------------------------|
| G9 LED 5W max. non fournie<br>G9 LED 5W max. not included | Variable*<br>Dimmable* |
|---|------------------------|

## Norme Standard

|      |           |
|------|-----------|
| IP44 | Classe II |
| IP44 | Class II  |

## Designer

Émilie Cathelineau

\* Les luminaires variables nécessitent l'utilisation d'ampoules compatibles avec la variation.  
All dimmable light fixtures require the use of compatible bulbs.

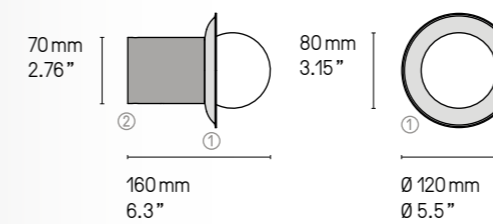

IP Janed 160 SG



IP Janed 160 SN



# IP LINK



## Finitions Finishes

Détails page 285

|   |  |  |  |                              |
|---|--|--|--|------------------------------|
| ● Laiton satiné<br><b>SB</b> Satin brass  | ● Graphite satiné<br><b>SG</b> Satin graphite  | ● Nickel satiné<br><b>SN</b> Satin nickel  | ● Cuivre satiné<br><b>SC</b> Satin copper  | ● Bronze<br><b>BZ</b> Bronze |
| ● Laiton poli<br><b>PB</b> Polished brass | ● Graphite poli<br><b>PG</b> Polished graphite | ● Nickel poli<br><b>PN</b> Polished nickel | ● Cuivre poli<br><b>PC</b> Polished copper |                              |

## Matériaux Materials

|                              |  |  |
|------------------------------|--|--|
| Laiton massif<br>Solid Brass | Diffuseur polycarbonate satiné<br>Satin Polycarbonate diffuser | Ruban Led sans points visibles<br>Led strip without visible dots |
|------------------------------|--|--|

## Source Lamping

Valeurs nominales  
Nominal values

|  |        |         |     |                             |
|--|--------|---------|-----|-----------------------------|
| <b>IP Link 410 (410 mm - 16.1")</b>          |        |         |     |                             |
| LED intégrée                                 | 160 lm | 3 000°K | 2W  | Alimentation 24V intégrée   |
| Integrated LED                               | 160 lm | 3 000°K | 2W  | Int. power supply 24V incl. |
| <b>IP Link 580 (580 mm - 22.8")</b>          |        |         |     |                             |
| LED intégrée                                 | 330 lm | 3 000°K | 4W  | Alimentation 24V intégrée   |
| Integrated LED                               | 330 lm | 3 000°K | 4W  | Int. power supply 24V incl. |
| <b>IP Link double 610 (610 mm - 24.1")</b>   |        |         |     |                             |
| LED intégrée                                 | 320 lm | 3 000°K | 4W  | Alimentation 24V intégrée   |
| Integrated LED                               | 320 lm | 3 000°K | 4W  | Int. power supply 24V incl. |
| <b>IP Link double 960 (960 mm - 37.8")</b>   |        |         |     |                             |
| LED intégrée                                 | 660 lm | 3 000°K | 7W  | Alimentation 24V intégrée   |
| Integrated LED                               | 660 lm | 3 000°K | 7W  | Int. power supply 24V incl. |
| <b>IP Link double 1300 (1300 mm - 51.2")</b> |        |         |     |                             |
| LED intégrée                                 | 880 lm | 3 000°K | 10W | Alimentation 24V intégrée   |
| Integrated LED                               | 880 lm | 3 000°K | 10W | Int. power supply 24V incl. |

## Norme Standard

For UL and Damp versions,  
please refer to page 146

|      |           |
|------|-----------|
| IP44 | Classe II |
| IP44 | Class II  |

## Norme Standard

## Designer

Émilie Cathelineau

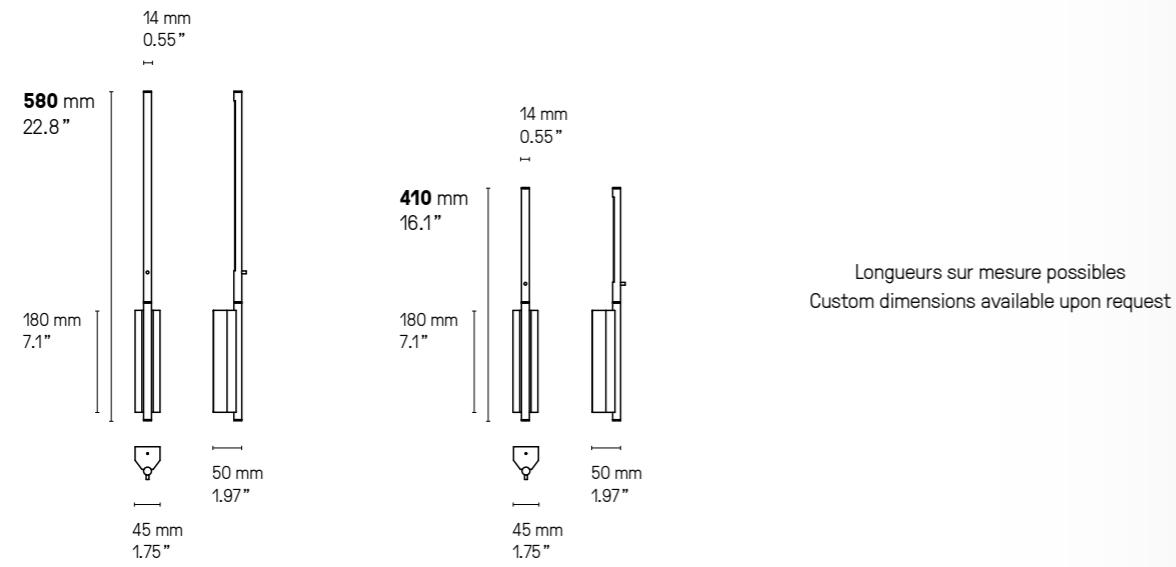

Longueurs sur mesure possibles  
Custom dimensions available upon request

**Double**  
1300 mm / 51.2"

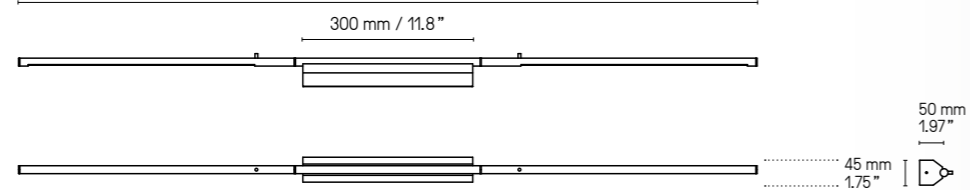

**Double**  
960 mm / 37.8"

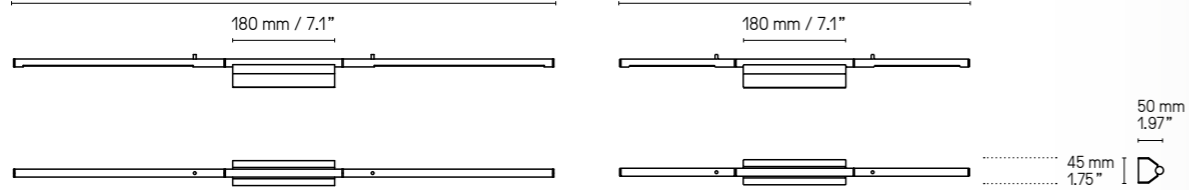

**Double**  
610 mm / 24.1"

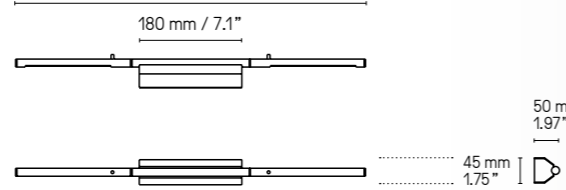

IP Link Double 960 PG



IP Link 410 SB



# IP METROP



## Finitions Finishes

Détails page 285

|   |  |  |  |                              |
|---|--|--|--|------------------------------|
| ● Laiton satiné<br><b>SB</b> Satin brass  | ● Graphite satiné<br><b>SG</b> Satin graphite  | ● Nickel satiné<br><b>SN</b> Satin nickel  | ● Cuivre satiné<br><b>SC</b> Satin copper  | ● Bronze<br><b>BZ</b> Bronze |
| ● Laiton poli<br><b>PB</b> Polished brass | ● Graphite poli<br><b>PG</b> Polished graphite | ● Nickel poli<br><b>PN</b> Polished nickel | ● Cuivre poli<br><b>PC</b> Polished copper |                              |

## Matériaux Materials

|                              |  |  |
|------------------------------|--|--|
| Laiton massif<br>Solid Brass | Diffuseur polycarbonate satiné<br>Satin Polycarbonate diffuser | Ruban Led sans points visibles<br>Led strip without visible dots |
|------------------------------|--|--|

## Source Lamping

Valeurs nominales  
Nominal values

|                      |        |         |    |                             |                           |
|----------------------|--------|---------|----|-----------------------------|---------------------------|
| <b>IP Metrop 325</b> |        |         |    |                             |                           |
| LED intégrée         | 330 lm | 3 000°K | 4W | Alimentation 24V intégrée   | Non variable en standard  |
| Integrated LED       | 330 lm | 3 000°K | 4W | Int. power supply 24V incl. | Standard version not dim. |
| <b>IP Metrop 525</b> |        |         |    |                             |                           |
| LED intégrée         | 550 lm | 3 000°K | 7W | Alimentation 24V intégrée   | Non variable en standard  |
| Integrated LED       | 550 lm | 3 000°K | 7W | Int. power supply 24V incl. | Standard version not dim. |
| <b>IP Metrop 780</b> |        |         |    |                             |                           |
| LED intégrée         | 825 lm | 3 000°K | 9W | Alimentation 24V intégrée   | Non variable en standard  |
| Integrated LED       | 825 lm | 3 000°K | 9W | Int. power supply 24V incl. | Standard version not dim. |

## Norme Standard

|      |           |
|------|-----------|
| IP44 | Classe II |
| IP44 | Class II  |

## Designer

Émilie Cathelineau

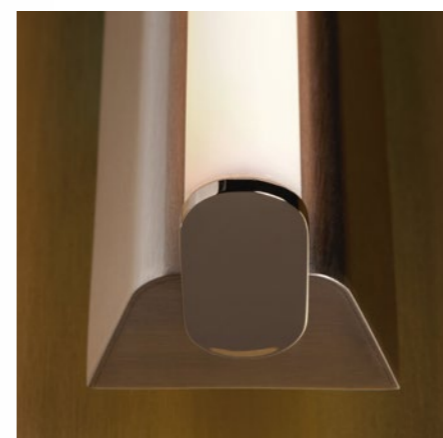

IP Metrop SG/PG



IP Metrop SB/SG

**IP Metrop**

325 mm  
12.8"

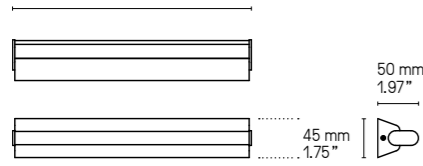

525 mm  
20.7"

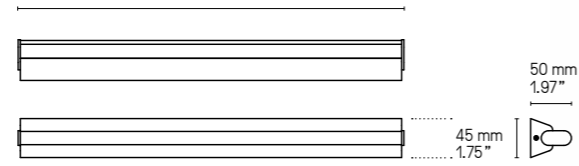

780 mm  
30.7"

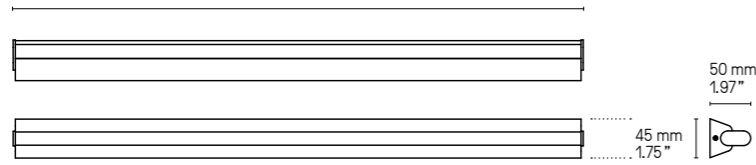

Longueurs sur mesure possibles  
Custom dimensions available upon request



IP Metrop 325 PB



IP Metrop 325 SG

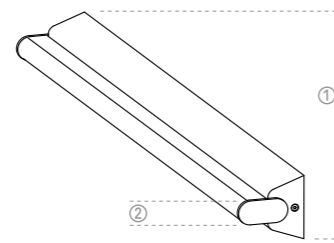

IP Metrop 325 SN/SG



IP Metrop 325 PN



IP Metrop 325 PC

**US Version**  
fitted plate to cover outlet power box

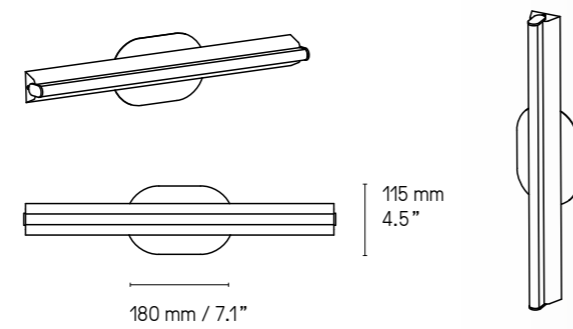

IP Metrop SB/SG



# IP SIGNAL



## Finitions Finishes

Détails page 285

|   |  |  |  |                              |
|---|--|--|--|------------------------------|
| ● Laiton satiné<br><b>SB</b> Satin brass  | ● Graphite satiné<br><b>SG</b> Satin graphite  | ● Nickel satiné<br><b>SN</b> Satin nickel  | ● Cuivre satiné<br><b>SC</b> Satin copper  | ● Bronze<br><b>BZ</b> Bronze |
| ● Laiton poli<br><b>PB</b> Polished brass | ● Graphite poli<br><b>PG</b> Polished graphite | ● Nickel poli<br><b>PN</b> Polished nickel | ● Cuivre poli<br><b>PC</b> Polished copper |                              |

## Matériaux Materials

|                              |  |
|------------------------------|--|
| Laiton massif<br>Solid Brass | Diffuseur polycarbonate satiné<br>Satin Polycarbonate diffuser |
|------------------------------|--|

## Source Lamping

Valeurs nominales  
Nominal values

|  |                                 |                      |  |
|--|---------------------------------|----------------------|--|
| <b>IP Signal 375</b> (375 mm - 14.8")        |                                 |                      |  |
| LED intégrée 280 lm 3000°K 5W                | Alimentation 24 V intégrée      | Variable (phase cut) |  |
| Integrated LED 280 lm 3000°K 5W              | Int. power supply 24 V included | Dimmable (phase cut) |  |
| <b>IP Signal 475</b> (475 mm - 18.7")        |                                 |                      |  |
| LED intégrée 480 lm 3000°K 8W                | Alimentation 24 V intégrée      | Variable (phase cut) |  |
| Integrated LED 480 lm 3000°K 8W              | Int. power supply 24 V included | Dimmable (phase cut) |  |
| <b>IP Signal 575</b> (575 mm - 22.6")        |                                 |                      |  |
| LED intégrée 670 lm 3000°K 10W               | Alimentation 24 V intégrée      | Variable (phase cut) |  |
| Integrated LED 670 lm 3000°K 10W             | Int. power supply 24 V included | Dimmable (phase cut) |  |
| <b>IP Signal double 580</b> (580 mm - 22.8") |                                 |                      |  |
| LED intégrée 570 lm 3000°K 9W                | Alimentation 24 V intégrée      | Variable (phase cut) |  |
| Integrated LED 570 lm 3000°K 9W              | Int. power supply 24 V included | Dimmable (phase cut) |  |
| <b>IP Signal double 780</b> (780 mm - 30.7") |                                 |                      |  |
| LED intégrée 960 lm 3000°K 14W               | Alimentation 24 V intégrée      | Variable (phase cut) |  |
| Integrated LED 960 lm 3000°K 14W             | Int. power supply 24 V included | Dimmable (phase cut) |  |
| <b>IP Signal double 980</b> (980 mm - 38.6") |                                 |                      |  |
| LED intégrée 1340 lm 3000°K 19W              | Alimentation 24 V intégrée      | Variable (phase cut) |  |
| Integrated LED 1340 lm 3000°K 19W            | Int. power supply 24 V included | Dimmable (phase cut) |  |

## Norme Standard

For UL and Damp versions,  
please refer to page 210

|      |           |
|------|-----------|
| IP44 | Classe II |
| IP44 | Class II  |

## Designer

Pauline Deltour

**IP Signal double 980**

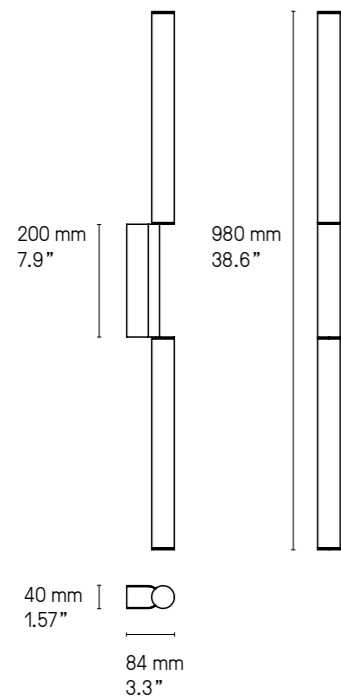

**IP Signal double 780**

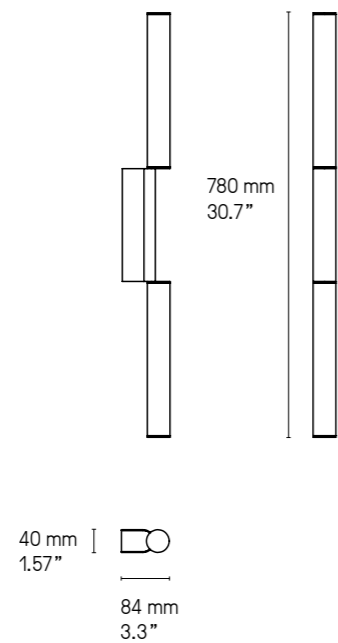

**IP Signal double 580**

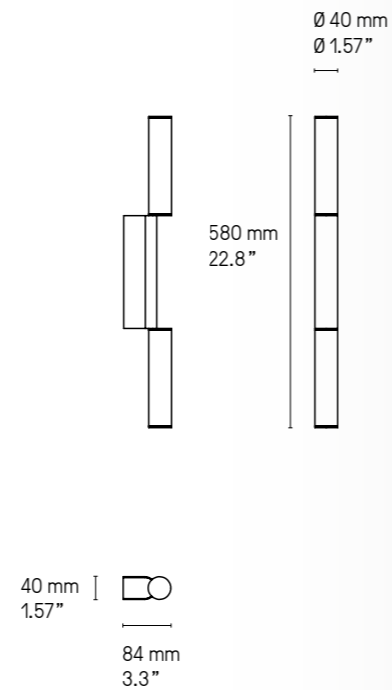

**IP Signal simple 575**

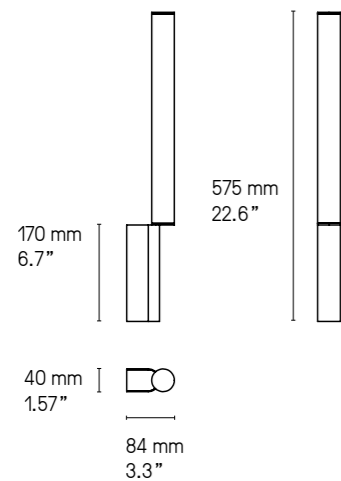

**IP Signal simple 475**

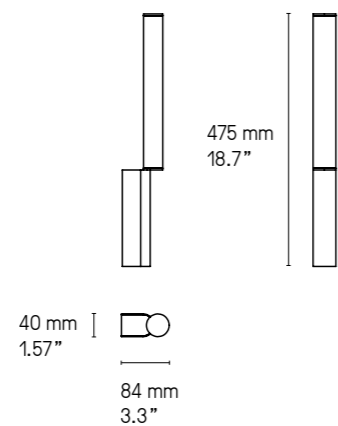

**IP Signal simple 375**

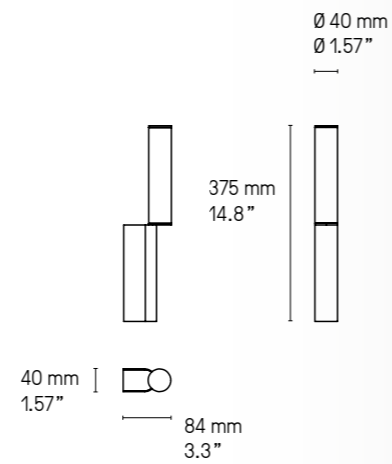

*Signal peut être installée horizontalement ou verticalement.  
Signal can be placed both horizontally or vertically on the wall.*



IP Signal Double 980 SN



IP Signal Simple 475 PN



IP Signal Simple 475 PB



# IP STORM



## Finitions Finishes

Détails page 285

|   |  |  |  |                              |
|---|--|--|--|------------------------------|
| ● Laiton satiné<br><b>SB</b> Satin brass  | ● Graphite satiné<br><b>SG</b> Satin graphite  | ● Nickel satiné<br><b>SN</b> Satin nickel  | ● Cuivre satiné<br><b>SC</b> Satin copper  | ● Bronze<br><b>BZ</b> Bronze |
| ● Laiton poli<br><b>PB</b> Polished brass | ● Graphite poli<br><b>PG</b> Polished graphite | ● Nickel poli<br><b>PN</b> Polished nickel | ● Cuivre poli<br><b>PC</b> Polished copper |                              |

## Matériaux Materials

|                              |   |
|------------------------------|---|
| Laiton massif<br>Solid Brass | Diffuseur polycarbonate blanc<br>White Polycarbonate diffuser |
|------------------------------|---|

## Source Lamping

Valeurs nominales  
Nominal values

|                                |        |         |    |  |   |
|--------------------------------|--------|---------|----|--|---|
| LED intégrée<br>Integrated LED | 440 lm | 3 000°K | 5W | Alimentation 24V intégrée<br>Int. power supply 24V incl. | Non variable en standard<br>Standard version not dim. |
|--------------------------------|--------|---------|----|--|---|

## Norme Standard

|      |           |
|------|-----------|
| IP44 | Classe II |
| IP44 | Class II  |

## Designer

Émilie Cathelineau

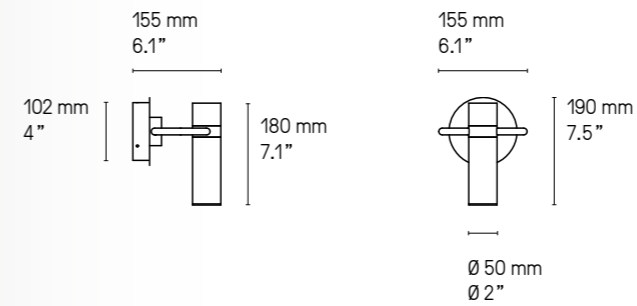

IP Storm SB

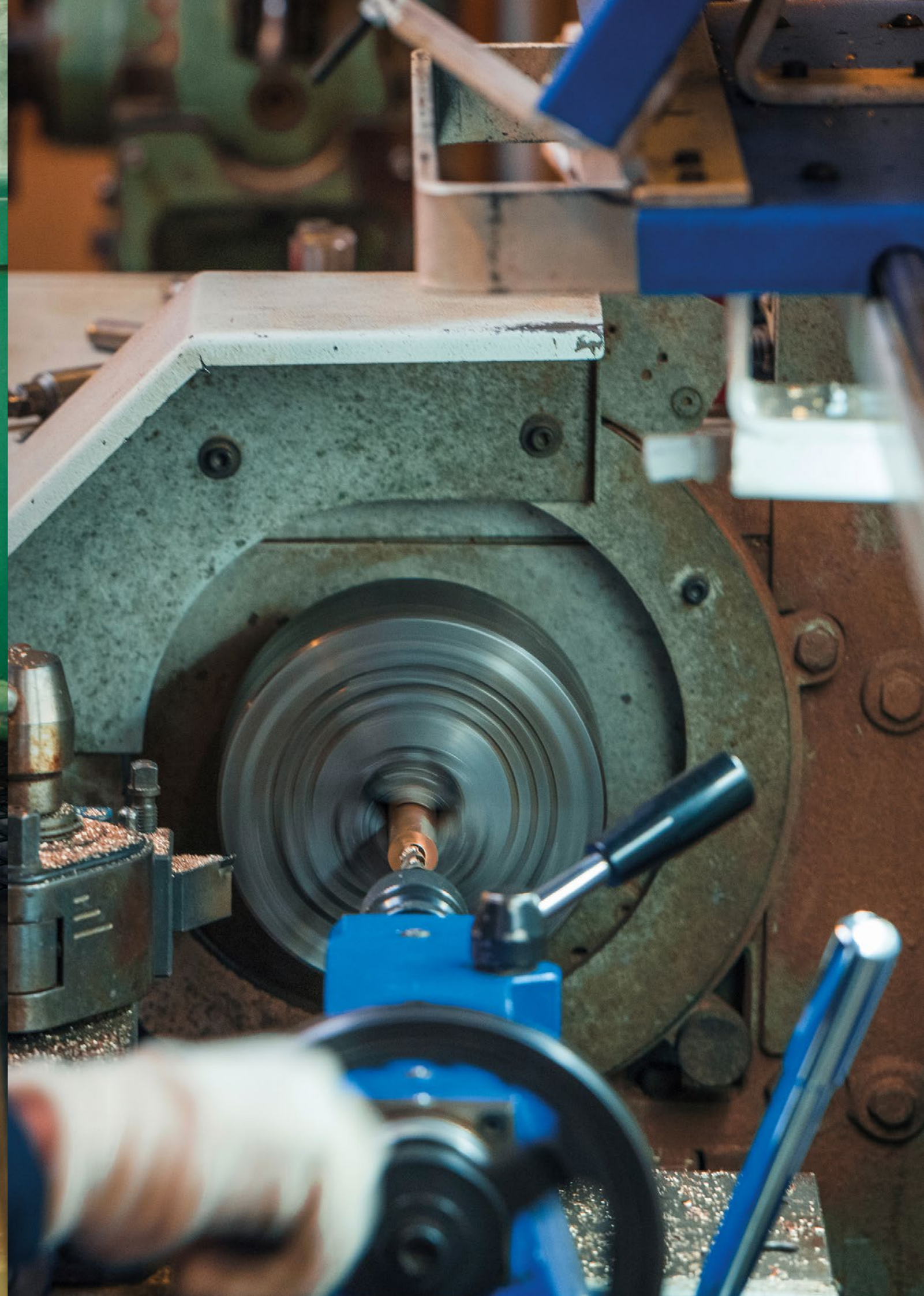





## NUANCIER - FINISH OPTIONS



### LAITON - BRASS

- |                                    |   |                                     |                                     |                       |
|------------------------------------|---|-------------------------------------|-------------------------------------|-----------------------|
| ① Laiton satiné<br>SB Satin brass  | ② Graphite satiné<br>SG Satin graphite  | ③ Nickel satiné<br>SN Satin nickel  | ④ Cuivre satiné<br>SC Satin copper  | ⑨ Bronze<br>BZ Bronze |
| ⑤ Laiton poli<br>PB Polished brass | ⑥ Graphite poli<br>PG Polished graphite | ⑦ Nickel poli<br>PN Polished nickel | ⑧ Cuivre poli<br>PC Polished copper |                       |

### ABAT-JOURS - LAMPSHADES



### AUTRES - OTHERS

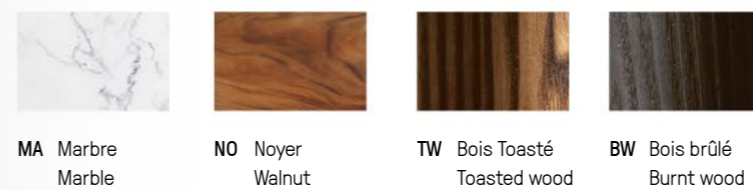

### VERRERIE - GLASS



### CÂBLES - CABLES



**Charte graphique – Brand identity**  
POOL

**Réalisation, suivi de fabrication**  
**Layout, print process supervision**  
deuxpointdeux

**Impression – Printing**  
DBS Print France

## Images

### Portraits

Atelier Grand Angle (É. Cathelineau), Stephanie Füssenich (P. Deltour), Yannick Labrousse (POOL),  
droits réservés/all rights reserved (H. Langlais), Nicolas Delaroche (S. Willenz),  
Sébastien Haddouk (J. Lévy), Michel Giesbrecht (J-B. Fastrez)

### Atelier & détails – Workshop & details

Yannick Labrousse (p.2-11, 14, 72-73, 250, 255, 257, 261, 271, 273, 280-284)

### Photos produits & ambiances – Product & lifestyle photos

CVL, except:

3mille for Kelly Boukobza – villa Saint-Tropez (p.22)

Adrien Ozouf (p.161)

AR visual (p.256, 258, 262, 278)

Bastien Pigneul (p.58-61, 64-65, 80, 89, 134-135, 164-166, 170-174, 182-186, 188-189,196, 206-207, 275)

CGI Furniture (p.274)

Francis Amiand for Stéphanie Coutas architecte d'intérieur (p.27)

Frenchie Cristogatin for agence Jean-Christophe Peyrieux; stylist: Céline Hassen (p.147)

Garnier Studios (p.35-39, 46, 50, 96 ,106-110, 122, 138, 140, 143, 160, 178-179, 213-215, 217, 219, 222,

228, 232-233, 236-237, 240-241, 245, 245, 249, 265, 277)

Gname architecture studio (p.68)

Iqosa Interior and Architecture Design est. 2014 (p.203)

Klaas Verdrum for Mayelle architecture d'intérieur (p.212)

Laura Evrat Photographe (p.20-21, 142, 194-195, 217)

Mario Simon-Lafleur (p.78 ,83 , 86, 162, 164, 167)

Morgane Legall pour Lelièvre Paris (p.49)

Pro Design St-Petersburg (p.269)

Rainer Schär for Iria Degen – Hotel Märthof Basel (p.98)

Stephan Julliard for Studio Lally & Berger – Hôtel Le Meurice à Paris (p.53)

Yannick Labrousse for Studio AC – Adenauer (p.29)

Yannick Labrousse for POOL studio – project R0F01, Paris (p.47, 71)

Mikołaj Walczewski for Bernatowicz Architektura Team – Zakopan Railway Station (p.148-149)

