



# SCALA

DESIGNED BY ÉMILIE CATHELINÉAU

Applique murale en laiton, inspirée d'un langage architectural minimaliste. Son design joue sur l'emboîtement de tubes aux proportions variées, créant un rythme de volumes à la fois structuré et élégant. Le diffuseur en polycarbonate opalin adoucit la lumière, pour une présence à la fois graphique et discrète.



Brass wall light, inspired by a minimalist architectural language. Its design plays with the interlocking of tubes in varied proportions, creating a rhythm of volumes that is both structured and elegant. The opaline polycarbonate diffuser softens the light, giving it a presence that is both graphic and discreet.



Naboo Réflecteur + Spot VS SB

© CVL

---

**Finitions  
Finishes**

● Laiton satiné  
SB Satin brass

● Graphite satiné  
SG Satin graphite

● Nickel satiné  
SN Satin nickel

● Cuivre satiné  
SC Satin copper

● Bronze  
BZ Bronze

[Nuancier – Finish options](#)

● Laiton poli  
PB Polished brass

● Graphite poli  
PG Polished graphite

● Nickel poli  
PN Polished nickel

● Cuivre poli  
PC Polished copper

---

**Matériaux  
Materials**

Laiton massif  
Solid brass

Diffuseur polycarbonate  
Polycarbonate diffuser

---

**Source  
Lamping**

Applique – Wall light  
G9 LED 5W max. non fournie  
G9 LED 5W max. not included

Variation\*  
Dimmable\*

---

**Designer**

Émilie Cathelineau

---

\* Les luminaires variables nécessitent l'utilisation d'ampoules compatibles avec la variation.  
All dimmable light fixtures require the use of compatible bulbs.



Détail Scala BZ

**SCALA**

---

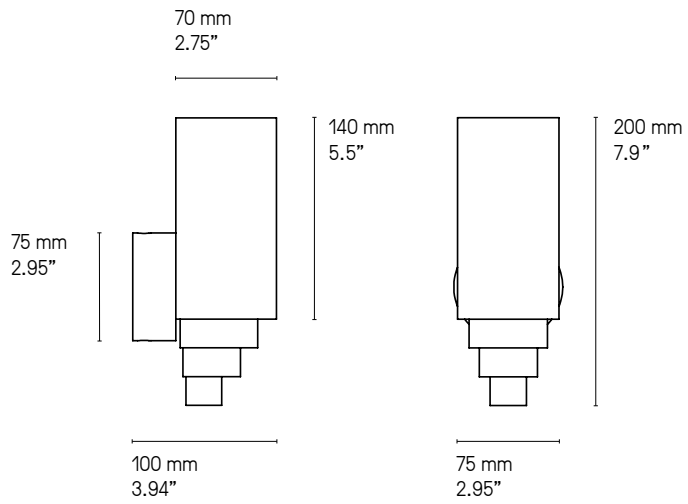

**US version  
fitted plate to cover  
outlet power box**

---

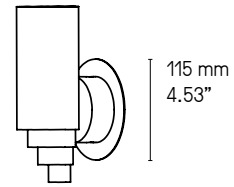

Scala PB



Scala SN



Scala SG

## NUANCIER - FINISH OPTIONS 2026



### LAITON - BRASS

- |                                    |   |                                     |                                     |                       |
|------------------------------------|---|-------------------------------------|-------------------------------------|-----------------------|
| ① Laiton satiné<br>SB Satin brass  | ② Graphite satiné<br>SG Satin graphite  | ③ Nickel satiné<br>SN Satin nickel  | ④ Cuivre satiné<br>SC Satin copper  | ⑨ Bronze<br>BZ Bronze |
| ⑤ Laiton poli<br>PB Polished brass | ⑥ Graphite poli<br>PG Polished graphite | ⑦ Nickel poli<br>PN Polished nickel | ⑧ Cuivre poli<br>PC Polished copper |                       |

### ABAT-JOURS - LAMPSHADES



Drop Paper® 100

Drop Paper® 101

Chinette blanche  
White chinette

Chinette noire  
Black chinette

Lin  
Linen

### AUTRES - OTHERS



MA Marbre  
Marble

NO Noyer  
Walnut

TW Bois Toasté  
Toasted wood

BW Bois brûlé  
Burnt wood

### VERRERIE - GLASS



Opale  
Opal

Opale et écaille  
Opal and patterned

Claire et écaille  
Clear and patterned

### CÂBLES - CABLES



Tissu noir  
Black textile

Tissu or  
Gold textile

TEL. +33 (0) 2 41 32 67 54 EMAIL : CONTACT@CVL-LUMINAIRES.FR

[WWW.CVL-LUMINAIRES.FR](http://WWW.CVL-LUMINAIRES.FR)