

HAUSSMANN

DESIGNED BY JOSÉ LÉVY

Les appliques *Hausmann* s'inscrivent dans l'ancrage parisien de José Lévy et son héritage haussmannien. Dans un travail de « déconstruction » de ce style iconique, le designer a détourné le motif ornemental des moulures intérieures pour sculpter la base de ces appliques.



The *Hausmann* wall lights are part of José Lévy's Parisian roots and his Haussmannian heritage. In a process of 'deconstruction' of this iconic style, the designer has reinterpreted the ornamental motif of interior mouldings to sculpt the base of these wall lights.



Finitions
Finishes

● Laiton satiné
SB Satin brass

● Graphite satiné
SG Satin graphite

● Nickel satiné
SN Satin nickel

● Cuivre satiné
SC Satin copper

● Bronze
BZ Bronze

[Nuancier – Finish options](#)

Matériaux
Materials

Tous – All
Laiton massif
Solid brass

Source
Lamping

Valeurs nominales
Nominal values

Appliques – Wall lights**Hausmann Small**

LED intégrée	840 lm	2700°K	12 W	Alimentation 24V intégrée	Variable (phase cut)
Integrated LED	840 lm	2700°K	12 W	Int. power supply 24 V included	Dimmable (phase cut)

Hausmann Large

LED intégrée	1690 lm	2700°K	20 W	Alimentation 24V intégrée	Variable (phase cut)
Integrated LED	1690 lm	2700°K	20 W	Int. power supply 24 V included	Dimmable (phase cut)

Designer

José Lévy



Hausmann Large SB

Hausmann Large

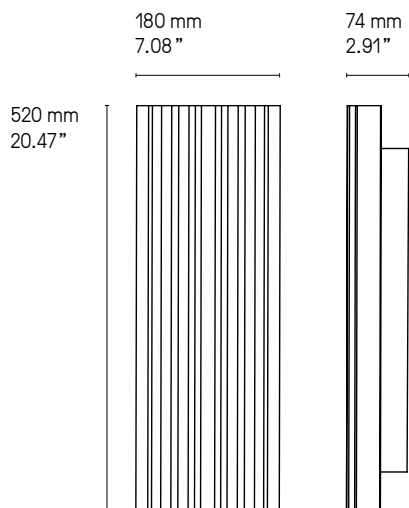

Hausmann Small

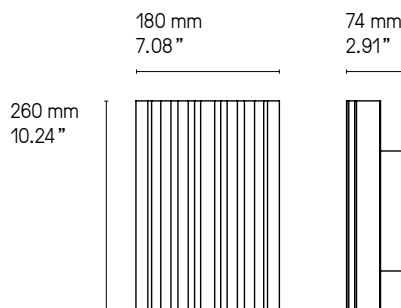

Hausmann Small SN



Hausmann Small SB

NUANCIER - FINISH OPTIONS 2026



LAITON - BRASS

- | | | | | |
|------------------------------------|---|-------------------------------------|-------------------------------------|-----------------------|
| ① Laiton satiné
SB Satin brass | ② Graphite satiné
SG Satin graphite | ③ Nickel satiné
SN Satin nickel | ④ Cuivre satiné
SC Satin copper | ⑨ Bronze
BZ Bronze |
| ⑤ Laiton poli
PB Polished brass | ⑥ Graphite poli
PG Polished graphite | ⑦ Nickel poli
PN Polished nickel | ⑧ Cuivre poli
PC Polished copper | |

ABAT-JOURS - LAMPSHADES



AUTRES - OTHERS



VERRERIE - GLASS



CÂBLES - CABLES

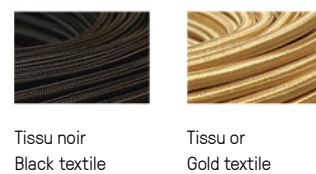

TEL. +33 (0) 2 41 32 67 54 EMAIL : CONTACT@CVL-LUMINAIRES.FR

WWW.CVL-LUMINAIRES.FR